

COMMISSIONER'S COURT AGENDA

May 13, 2019

NOTICE OF A MEETING OF THE COMMISSIONERS COURT
OF CALDWELL COUNTY, TEXAS



Notice is hereby given that an open meeting of the Caldwell County Commissioners Court will be held on the 13th day of May, 2019 at 9:00 A.M. in the 2nd Floor Courtroom, Caldwell County Courthouse located at 110 S. Main Street, Lockhart, Texas at which time the following subjects will be discussed, considered, passed or adopted, to wit:

Call Meeting to Order.

Invocation. Lockhart Ministerial Alliance

Pledge of Allegiance to the Flags.

(Texas Pledge: Honor the Texas Flag; I pledge allegiance to thee, Texas, one state under God, one and indivisible).

Announcements. Items or comments from Court members or staff.

Citizens' Comments. At this time any person may speak to Commissioners Court if they have filled out a Caldwell County Commissioners Court Participation Form. Comments will be limited to four (4) minutes per person. No action will be taken on these items and no discussion will be had between the speaker(s) and members of the Court. The Court does retain the right to correct factual inaccuracies made by the speakers. (If longer than 30 minutes, then the balance of comments will continue as the last agenda item of the day).

CONSENT AGENDA. (The following consent items may be acted upon in one motion).

1. Approve payment of County invoices in the amount of \$1,178,971.37; Backup: 42
2. Approve County Purchase Orders in the amount of \$17,300.53; Backup: 4
3. Ratify re-occurring County payments in the amount of:
 - A. \$ 286,087.79 (Payroll for 03/31/2019 – 04/13/2019); Backup: 21
 - B. \$ 86,371.16 (Payroll Tax for 03/31/2019 – 04/13/2019); Backup: 2
 - C. \$291,588.34 (Payroll for 4/14/19 – 4/27/19); Backup: 21
 - D. \$88,197.42 (Payroll Tax for 4/14/19 – 4/27/19); Backup: 2
 - E. \$259,738.13 (Department of Motor Vehicle Fees-March 2019); Backup: 2
 - F. \$405,060.49 (Department of Motor Vehicles Comptroller); Backup: 14
 - G. \$253.75 (Texas Boat and Motor Sales); Backup: 3
 - H. \$163,408.55 (Department of Motor Vehicles Fees-April 2019); Backup: 2
 - I. \$29,447.68 (April 2019 Utilities); Backup: 2

Filed this 9th day of May 2019
3:46 P.M.

TERESA RODRIGUEZ
COUNTY CLERK, CALDWELL COUNTY, TEXAS
By Mittany Donner Deputy

4. **Accept January-March 2019 Reports from Caldwell County Extension Office:**
 - A. **Julie Zimmerman; Backup: 3**
 - B. **Wayne Morse (Jan.-Apr.); Backup: 8**
 - C. **Elsie Lacy; Backup: 6**
5. **Accept February-March 2019 report from Constable, Precinct 2; Backup: 2**
6. **Accept the April 2019 Environmental Investigator report from Mike Bittner; Backup: 3**
7. **Accept the Caldwell County Appraisal District's April 2019 Tax Collection Report. Backup: 4**
8. **To accept a donation of a Risepro Sound Level Meter to Constable Precinct 2; Backup 3**

SPECIAL PRESENTATIONS

Mr. Nirav Ved, Special Assistant to the CAMPO Executive Director will provide a brief overview of the Luling Transportation Study; **Backup: 39**

AGENDA ACTION ITEMS

9. **Discussion/Action** regarding the burn ban. **Cost: None; Speaker: Judge Haden / Carine Chalfoun; Backup: None.**
10. **Discussion/Action** to issue an order allowing retail fireworks permit holders to sell fireworks to the public in celebration of Memorial Day pursuant to Occupations Code Section 2154.202(h)(1). **Cost: None; Speaker: Judge Haden/Carine Chalfoun; Backup: 2**
11. **Discussion/Action** to reschedule the May 27, 2019 regularly scheduled Commissioners Court Meeting. **Cost: None; Speaker: Judge Haden; Backup: 1**
12. **Discussion/Action** to approve Proclamation declaring May 2019 as Elder Abuse Prevention Awareness Month. **Cost: None; Speaker: Judge Haden; Backup: 3**
13. **Discussion/Action** to approve Proclamation declaring May 19-25, 2019 as EMS Week. **Cost: None; Speaker: Judge Haden; Backup: 2**
14. **Discussion/Action** to approve Resolution 18-2019 to submit a grant to the Texas Judicial Commission on Mental Health. **Cost: None; Speakers: Judge Haden/Dennis Engelke; Backup: 4**
15. **Discussion/Action** to approve Resolution 19-2019 supporting the construction of FM 110 from State Highway 123 to I-35 at Yarrington Road. **Cost: None; Speaker: Commissioner Theriot; Backup: 3**

16. **Discussion/Action** to approve a \$900.00 donation request from Caldwell-Travis Soil and Water Conservation District #304. **Cost: \$900.00; Speaker: Judge Haden; Backup: 3**
17. **Discussion/Action** to approve Budget Amendment #22 from Court Admin Assistant (001-6510-1040) to Dues and Subscription (001-6560-3050) **Cost: None; Speaker: Judge Haden; Backup: 3**
18. **Discussion/Action** to approve Budget Amendment #23 for money given by Texas State Safety Center. Will be added to Budget for operations. **Cost: none; Speaker: Judge Haden/ Steve Kenney/ Constable Bell; Backup: 2**
19. **Discussion/Action** to approve Budget Amendment #24 to move money from 010-3000-0499 CC-HMAP-J20 revenue line item to 010-6650-4110 Professional Services expense line item. **Cost: None; Speakers: Judge Haden/Dennis Engelke; Backup: 3**
20. **Discussion/Action** to approve Budget Amendment #25 to move remaining money from 001-2140-1040 to 3 Deputy Clerks 001-2140-1040. **Cost: None; Speakers: Darla Law/ Judge Haden; Backup: 2**
21. **Discussion/Action** to approve Budget Amendment #26 to move money from Constable, Pct. 2, office supplies 001-432-3110 to Machinery and equipment, 001-4322-5310 to cover expenses for radar certifications. **Cost: None; Speaker: Judge Haden/ Tom Will; Backup: 3**
22. **Discussion/Action** to approve Job Descriptions for Executive Assistant and Administrative Assistant – County Commissioners. **Cost: None; Speaker: Judge Haden/Bob Bush; Backup: 7**
23. **Discussion/Action** to review and approve the annual financial audit report for the fiscal year ending September 30, 2018. **Cost: None; Speakers: Lewis Crain, CPA/ Barbara Gonzales/ Judge Haden; Backup: 77**
24. **Discussion/Action** to discuss approving Farmer’s Market Courthouse Lawn use application. **Cost: None; Speaker: Judge Haden; Backup: 6**
25. **Discussion/Action** to approve the Interlocal Cooperative Agreement between Caldwell County and the City of Luling for subdivision regulation within the extraterritorial jurisdiction of the City of Luling. **Cost: None; Speaker: Judge Haden; Backup: 7**
26. **Discussion/Action** requesting approval to purchase and issue purchase order for the Unit Road equipment from Freightliner of Austin. **Cost:\$783,598.32; Speakers: Judge Haden/ Danie Blake; Backup 101**

27. **Discussion/Action** to approve Lease agreement between Caldwell County and the Health and Human Services Commission **Cost: None; Speaker: Judge Haden; Backup: 10**
28. **PUBLIC HEARING at 9:30 AM** concerning the approval of a Preliminary Plat for Hartland Subdivision to include 20 lots on approximately 177.5 acres located on Borchert Loop. **Cost: None. Speaker: Commissioner Westmoreland /Kasi Miles. Backup: 8**
29. **Discussion/ Action** to consider the approval of the Preliminary Plat for Hartland Ranch Subdivision to include 20 lots on approximately 177.5 acres located on Borchert Loop. **Cost: None. Speaker: Commissioner Westmoreland /Kasi Miles. Backup: 32**
30. **Discussion/ Action** to consider the approval of the Preliminary Plat for Lytton Hills Subdivision, Phase One to include 75 lots on approximately 458.59 acres located on FM 1854. **Cost: None. Speaker: Commissioner Roland /Kasi Miles. Backup: 44.**
31. **Discussion/Action** to discuss Employee Compensation for FY 2020 budget cycle. **Cost: TBD; Speaker: Judge Haden; Backup: 1**
32. **EXECUTIVE SESSION** pursuant to Sections 551.071 and 551.087 of the Texas Government Code: consultation with counsel and deliberation regarding economic development negotiations associated with Fashion Glass and Mirror, L.L.C. Possible action may follow in open court. **Cost: TBD; Speaker: Judge Haden; Backup: None.**

33. Adjournment.

As authorized by Chapter 551 of the Texas Government Code, the Commissioners Court of Caldwell County, Texas reserves the right to adjourn into Executive Session at any time during the course of this meeting to discuss any of the matters listed above. The Court may adjourn for matters that may relate to Texas Government Code Section 551.071(1) (Consultation with Attorney about pending or contemplated litigation or settlement offers); Texas Government Code Section 551.071(2) (Consultation with Attorney when the attorney's obligations under the Texas Disciplinary Rules of Professional Conduct of the State Bar of Texas conflicts with Chapter 551 of the Texas Government Code); Texas Government Code Section 551.072 (Deliberations about Real Property); Texas Government Code Section 551.073 (Deliberations about Gifts and Donations); Texas Government Code Section 551.074 (Personnel Matters); Texas Government Code Section 551.0745 (Deliberations about a County Advisory Body); Texas Government Code Section 551.076 (Deliberations about Security Devices); and Texas Government Code Section 551.087 (Economic Development Negotiations). In the event that the Court adjourns into Executive Session, the Court will announce under what section of the Texas Government Code the Commissioners Court is using as its authority to enter into an Executive Session. The meeting facility is wheelchair accessible and accessible parking spaces are available. Request for accommodations or interpretive services must be made 48 hours prior to this meeting. Please contact the County Judge's office at 512-398-1808 for further information. www.co.caldwell.tx.us

Invocation – Lockhart Ministry Alliance

Pledge of Allegiance to the Flag.

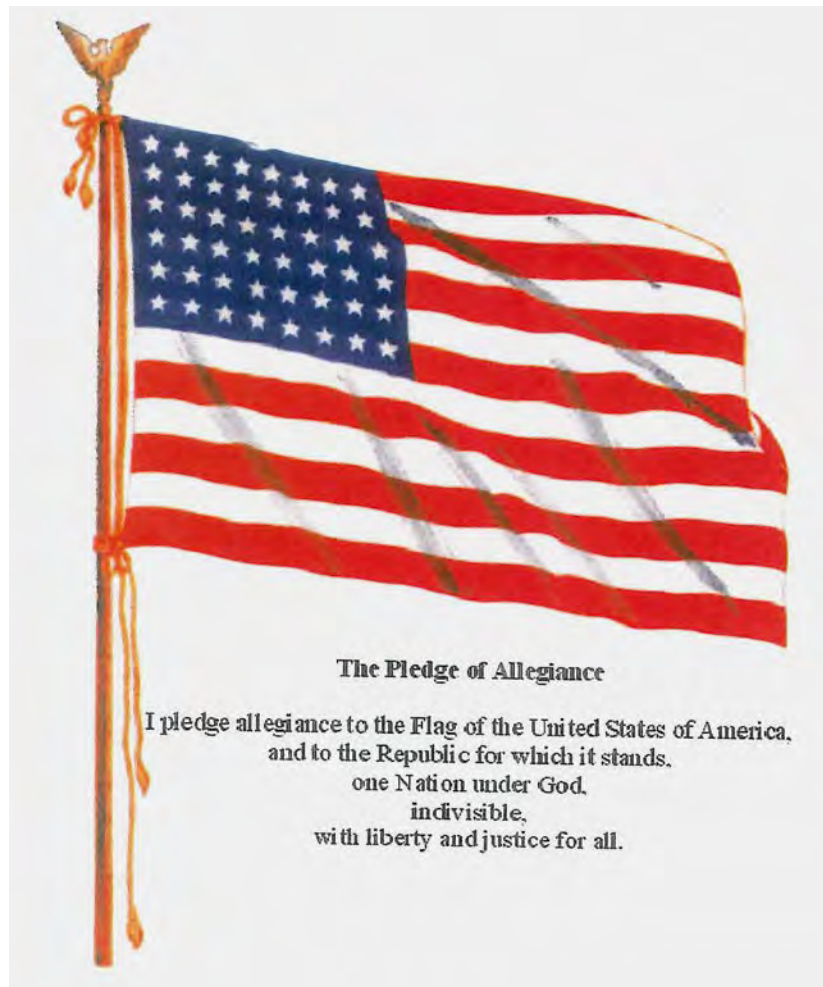

**(Texas Pledge: Honor the Texas flag;
I pledge allegiance to thee, Texas, one
state under God, one and indivisible).**

Pledge to the Texas Flag



Honor the Texas
Flag; I pledge
allegiance to thee,
Texas, one state
under God, one and
indivisible

Announcements:

**Items or comments from Court
Members or Staff.**

Citizens' Comments:

At this time any person may speak to Commissioners Court if they have filled out a Caldwell County Commissioners Court Participation Form. Comments will be limited to four (4) minutes per person. No action will be taken on these items and no discussion will be had between the speaker(s) and members of the Court. The Court does retain the right to correct factual inaccuracies made by the speakers. (If longer than 30 minutes, then the balance of comment will continue as the last agenda item of the day).

Consent Agenda. (The following consent items may be acted upon in one motion.)

- 1. Approve payment of County invoices in the amount of \$ 1,178,971.37; Backup: 28**

Caldwell County Agenda Item Request Form

To: All Elected Officials and Department Heads – Hand deliver or scan & email to hobby.haden@co.caldwell.tx.us and ezzy.chan@co.caldwell.tx.us . Deadline is 5:00 pm Tuesday before the Regular meetings, however, please submit this completed form ASAP. "Anything missing will cause the Agenda Item to be held over to the next Regular meeting," according to our Rules & Procedures.

AGENDA DATE: 5/13/2019

Type of Agenda Item

- Consent Discussion/Action Executive Session Workshop
 Public Hearing

What will be discussed? What is the proposed motion?

to approve County invoices in the amount of \$1,178,971.37

1. Costs:

Actual Cost or Estimated Cost \$ _____

Is this cost included in the County Budget? _____

Is a Budget Amendment being proposed? _____

2. Agenda Speakers:

Name	Representing	Title

(1) _____

(2) _____

(3) _____

3. Backup Materials:

None To Be Distributed 42 total # of backup pages
~~28~~
(including this page)

4. 
Signature of Court Member

Date 5/7/2019

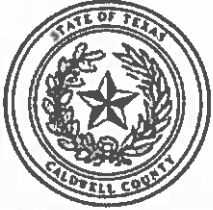

Caldwell County, TX

Payment Register

APPKT03083 - 5/13/19 A/P RUN

01 - Vendor Set 01

Bank: AP BNK - Pooled Cash - Operation

Vendor Number	Vendor Name			Total Vendor Amount
<u>PHOMOR</u>	4 SQUARE COMMUNICATIONS, LLC			2,480.98
Payment Type	Payment Number	Payment Date	Payment Amount	
Check		05/06/2019	2,480.98	
Payable Number	Description	Payable Date	Due Date	Discount Amount Payable Amount
<u>3755</u>	REPLACED CAMERA IN A & B CATWALK. FUSE WAS BLOW	04/23/2019	05/13/2019	0.00 290.98
<u>3768</u>	ADMIN 2 NOT WORKING - PLACED LOANER DVR	12/20/2018	05/13/2019	0.00 1,020.00
<u>3769</u>	TESTED LT. LARIVEE'S COMPUTER FOR CONNECTION TO	01/03/2019	05/13/2019	0.00 295.00
<u>3770</u>	RECORDING SLOW ON COMPUTER - REBOOTED SYSTEM	03/19/2019	05/13/2019	0.00 115.00
<u>3772</u>	OUTDOOR CAMERA VARIFOCAL 2.8 TO 12MM	04/26/2019	05/13/2019	0.00 760.00

Vendor Number	Vendor Name			Total Vendor Amount
<u>ADARQW</u>	ADAM D. ROWINS			945.00
Payment Type	Payment Number	Payment Date	Payment Amount	
Check		05/06/2019	945.00	
Payable Number	Description	Payable Date	Due Date	Discount Amount Payable Amount
<u>18-FL-192</u>	CAUSE # 18-FL-192 R.S.S.G.	04/25/2019	05/13/2019	0.00 126.00
<u>18-FL-317 6</u>	CAUSE # 18-FL-317 K.V.	04/25/2019	05/13/2019	0.00 343.00
<u>18-FL-539 3</u>	CAUSE # 18-FL-539 N.C.M.	04/25/2019	05/13/2019	0.00 126.00
<u>19-FL-047 2</u>	CAUSE # 19-FL-047 J.G. / M.M.	04/25/2019	05/13/2019	0.00 77.00
<u>19-FL-074 1</u>	CAUSE # 19-FL-074 A.S.	04/25/2019	05/13/2019	0.00 77.00
<u>19-FL-103</u>	CAUSE # 19-FL-103 O.O.JR/A.O.	04/25/2019	05/13/2019	0.00 196.00

Vendor Number	Vendor Name			Total Vendor Amount
<u>JAMHAN</u>	ADOPTION LAW FIRM OF TEXAS, PC			882.00
Payment Type	Payment Number	Payment Date	Payment Amount	
Check		05/06/2019	882.00	
Payable Number	Description	Payable Date	Due Date	Discount Amount Payable Amount
<u>18-FL-317</u>	CAUSE # 18-FL-317 K.V./U.G./A.T.A./J.A.	04/25/2019	05/13/2019	0.00 420.00
<u>19-FL-047</u>	CAUSE # 19-FL-047 M.H. / J.G.	04/25/2019	05/13/2019	0.00 238.00
<u>19-FL-091</u>	CAUSE # 19-FL-091 J.S./O.S./A.S./A.S.	04/25/2019	05/13/2019	0.00 224.00

Vendor Number	Vendor Name			Total Vendor Amount
<u>AERDYN</u>	AERODYNAMICS AIRCONDITIONING & REFRIG.			470.00
Payment Type	Payment Number	Payment Date	Payment Amount	
Check		05/06/2019	470.00	
Payable Number	Description	Payable Date	Due Date	Discount Amount Payable Amount
<u>1162</u>	REPLACED FAN MOTOR ON W-3	04/03/2019	05/13/2019	0.00 470.00

Vendor Number	Vendor Name			Total Vendor Amount
<u>AIRCOM</u>	AIR COMMUNICATIONS, CO., INC.			161.22
Payment Type	Payment Number	Payment Date	Payment Amount	
Check		05/06/2019	161.22	
Payable Number	Description	Payable Date	Due Date	Discount Amount Payable Amount
<u>16855</u>	CARRIER - 3.0" OD TELESCOPING	04/10/2019	05/13/2019	0.00 161.22

Vendor Number	Vendor Name			Total Vendor Amount
<u>ALDOS</u>	AL DOS SANTOS			112.40
Payment Type	Payment Number	Payment Date	Payment Amount	
Check		05/06/2019	112.40	
Payable Number	Description	Payable Date	Due Date	Discount Amount Payable Amount
<u>42019</u>	ACCREDITATION TRAINING 4/15 & 16/19	04/19/2019	05/13/2019	0.00 112.40

Payment Register

APPKT03083 - 5/13/19 A/P RUN

Vendor Number	Vendor Name					Total Vendor Amount
<u>ALAARE</u>	ALAMO AREA COUNCIL OF GOVERNMENTS					50.00
Payment Type	Payment Number					
Check						
Payable Number	Description	Payable Date	Due Date	Discount Amount	Payable Amount	
<u>04057</u>	SEAN QUINN - INVESTIGATION OF WHITE COLLAR 3/25/1	03/25/2019	05/13/2019	0.00	50.00	
<u>ABLUN</u>	ALBERTO LUNA					210.00
Payment Type	Payment Number					
Check						
Payable Number	Description	Payable Date	Due Date	Discount Amount	Payable Amount	
<u>41519</u>	CONFERENCE - FINGER ORUNT 4/8 - 11/19	04/15/2019	05/13/2019	0.00	210.00	
<u>AMAMON</u>	AMANDA MONTGOMERY					40.94
Payment Type	Payment Number					
Check						
Payable Number	Description	Payable Date	Due Date	Discount Amount	Payable Amount	
<u>42519</u>	MILEAGE FOR 4/25/19	05/02/2019	05/13/2019	0.00	40.94	
<u>APPCON</u>	APPLIED CONCEPTS, INC.					287.50
Payment Type	Payment Number					
Check						
Payable Number	Description	Payable Date	Due Date	Discount Amount	Payable Amount	
<u>345475</u>	2 X COUNTING UNIT, 1.5 PCB	04/01/2019	05/13/2019	0.00	287.50	
<u>ASCO</u>	ASSOCIATED SUPPLY COMPANY, INC					196,238.28
Payment Type	Payment Number					
Check						
Payable Number	Description	Payable Date	Due Date	Discount Amount	Payable Amount	
<u>013-03</u>	CUST # BP0068193 SINGLE DRUM ROLLER	04/08/2019	05/13/2019	0.00	196,095.24	
<u>PS0069185-1</u>	ORDER # PSO069185 CUST # BP0068193	04/16/2019	05/13/2019	0.00	143.04	
<u>CININT</u>	AT & T MOBILITY					417.89
Payment Type	Payment Number					
Check						
Payable Number	Description	Payable Date	Due Date	Discount Amount	Payable Amount	
<u>875648878X04232019</u>	ACCT # 875648878 BILLING PERIOD: 3/16 - 4/15/19	04/15/2019	05/13/2019	0.00	417.89	
<u>ATO189</u>	AT&T					6,250.14
Payment Type	Payment Number					
Check						
Payable Number	Description	Payable Date	Due Date	Discount Amount	Payable Amount	
<u>4052019</u>	ACCT # 512 A13-0189 725 3 4/5 - 5/4/19	04/05/2019	05/13/2019	0.00	6,250.14	
<u>ATCINT</u>	ATCO INTERNATIONAL					431.00
Payment Type	Payment Number					
Check						
Payable Number	Description	Payable Date	Due Date	Discount Amount	Payable Amount	
<u>10527049</u>	CUST ID: 126786 ALL PRO	03/29/2019	05/13/2019	0.00	307.00	
<u>10528494</u>	CUST ID: 126786	04/22/2019	05/13/2019	0.00	124.00	

Payment Register

APPKT03083 - 5/13/19 A/P RUN

Vendor Number	Vendor Name					Total Vendor Amount
<u>BAKDIS</u>	BAKER DISTRIBUTING COMPANY					459.26
Payment Type	Payment Number			Payment Date	Payment Amount	
Check				05/06/2019	459.26	
Payable Number	Description	Payable Date	Due Date	Discount Amount	Payable Amount	
<u>X737597</u>	CUST # 047519 KIT PUMP 115/60/1	04/17/2019	05/13/2019	0.00	234.62	
<u>X855100</u>	CUST # 047519 SCALE STICK	04/30/2019	05/13/2019	0.00	224.64	
<u>BENBOY</u>	BENNY BOYD LOCKHART, LLC					679.09
Payment Type	Payment Number			Payment Date	Payment Amount	
Check				05/06/2019	679.09	
Payable Number	Description	Payable Date	Due Date	Discount Amount	Payable Amount	
<u>31365</u>	ACCT # 5020 ACTUATOR	04/15/2019	05/13/2019	0.00	242.00	
<u>55922</u>	CUST # 10540 DODGE CHARGER VIN #2B3KA43GX7H771	04/24/2019	05/13/2019	0.00	437.09	
<u>BENPER</u>	BENNY PERRIRAZ					380.00
Payment Type	Payment Number			Payment Date	Payment Amount	
Check				05/06/2019	380.00	
Payable Number	Description	Payable Date	Due Date	Discount Amount	Payable Amount	
<u>41119</u>	76 HOG TAILS	04/11/2019	05/13/2019	0.00	380.00	
<u>BLUETR</u>	BLUEBONNET TRAILS MHMR					1,325.00
Payment Type	Payment Number			Payment Date	Payment Amount	
Check				05/06/2019	1,325.00	
Payable Number	Description	Payable Date	Due Date	Discount Amount	Payable Amount	
<u>102018</u>	TRAINING IN MENTAL HEALTH FIRST AID	05/01/2019	05/13/2019	0.00	525.00	
<u>27-03-2019</u>	ANASAZI VENDOR # 5915 MUNIS VENDOR # 27	04/05/2019	05/13/2019	0.00	800.00	
<u>BOBBUS</u>	BOB BUSH					189.00
Payment Type	Payment Number			Payment Date	Payment Amount	
Check				05/06/2019	189.00	
Payable Number	Description	Payable Date	Due Date	Discount Amount	Payable Amount	
<u>522019</u>	SHRM - PROFESSIONAL MEMBERSHIP 5/2019 - 5/31/2020	05/02/2019	05/13/2019	0.00	189.00	
<u>BOVMER</u>	BOVIK & MEREDITH P.C.					5,042.00
Payment Type	Payment Number			Payment Date	Payment Amount	
Check				05/06/2019	5,042.00	
Payable Number	Description	Payable Date	Due Date	Discount Amount	Payable Amount	
<u>18-FL-070 1</u>	CAUSE # 18-FL-070	04/25/2019	05/13/2019	0.00	1,260.00	
<u>18-FL-118 1</u>	CAUSE # 18-FL-118 B.B.S.B.	04/25/2019	05/13/2019	0.00	1,498.00	
<u>18-FL-318</u>	CAUSE # 18-FL-318 J.H.	04/25/2019	05/13/2019	0.00	906.50	
<u>18-FL-446</u>	CAUSE # 18-FL-446 J.M.	04/25/2019	05/13/2019	0.00	122.50	
<u>2665-18CC</u>	CAUSE # 2665-18CC / 2687-18CC A.B.	04/15/2019	05/13/2019	0.00	300.00	
<u>46974</u>	CAUSE # 46974 WENDY HURST	03/21/2019	05/13/2019	0.00	300.00	
<u>47260</u>	CAUSE # 47260 AMY RODRIGUEZ	03/21/2019	05/13/2019	0.00	300.00	
<u>47407</u>	CAUSE # 47407 OMAR MEDRANO	03/21/2019	05/13/2019	0.00	355.00	
<u>BOWMAN</u>	BOWMAN CONSULTING GROUP LTD					1,850.00
Payment Type	Payment Number			Payment Date	Payment Amount	
Check				05/06/2019	300.00	
Payable Number	Description	Payable Date	Due Date	Discount Amount	Payable Amount	
<u>269907</u>	PROJECT # 070004-14-005 COMPOSTELA SITE PLAN REVI	03/31/2019	05/13/2019	0.00	300.00	
Check				05/06/2019	450.00	
Payable Number	Description	Payable Date	Due Date	Discount Amount	Payable Amount	
<u>269908</u>	PROJECT # 070004-68-001 HARTLAND RANCH PRELIMIN	03/31/2019	05/13/2019	0.00	450.00	

Payment Register

APPKT03083 - 5/13/19 A/P RUN

Check	Payable Number	Description	Payable Date	Due Date	Discount Amount	Payable Amount	Total Vendor Amount
					05/06/2019	500.00	
	<u>269911</u>	PROJECT # 070004-77-001 FAMILY DOLLAR SITE PLAN	03/31/2019	05/13/2019	0.00	500.00	
Check					05/06/2019	300.00	
	<u>269912</u>	PROJECT # 070004-78-001 IONA ACRES SHORT FORM PL	03/31/2019	05/13/2019	0.00	300.00	
Check					05/06/2019	300.00	
	<u>269913</u>	PROJECT # 070004-79-001 STATE PARK ACRES SHORT FO	03/31/2019	05/13/2019	0.00	300.00	
Vendor Number	Vendor Name						Total Vendor Amount
<u>BRAVIN</u>	BRANDI VINKLAREK						65.00
Payment Type	Payment Number				Payment Date	Payment Amount	
Check					05/06/2019	65.00	
	<u>452019</u>	GALVESTON TRAINING 3/31 - 4/2/19	04/05/2019	05/13/2019	0.00	65.00	
Vendor Number	Vendor Name						Total Vendor Amount
<u>BRAMAT</u>	BRAUNTEX MATERIALS, INC.						93,660.60
Payment Type	Payment Number				Payment Date	Payment Amount	
Check					05/06/2019	93,660.60	
	<u>100679</u>	ACCT # 1600 REEDVILLE	04/08/2019	05/13/2019	0.00	70,722.00	
	<u>100840</u>	ACCT # 1600 1700 FM 2700	04/15/2019	05/13/2019	0.00	22,938.60	
Vendor Number	Vendor Name						Total Vendor Amount
<u>BUIIMA</u>	BUILDING IMAGE GROUP, INC.						150.00
Payment Type	Payment Number				Payment Date	Payment Amount	
Check					05/06/2019	150.00	
	<u>22672</u>	PROJECT # 22672 JUSTICE CENTER COURT SIGN	02/04/2019	05/13/2019	0.00	150.00	
Vendor Number	Vendor Name						Total Vendor Amount
<u>CALAPP</u>	CALDWELL COUNTY APPRAISAL DIST						2,176.55
Payment Type	Payment Number				Payment Date	Payment Amount	
Check					05/06/2019	2,176.55	
	<u>522019</u>	REIMBURSEMENT REQUEST 911/GIS POSITION	05/02/2019	05/13/2019	0.00	2,176.55	
Vendor Number	Vendor Name						Total Vendor Amount
<u>AUTPAR</u>	CAPITOL AUTO PARTS						1,201.69
Payment Type	Payment Number				Payment Date	Payment Amount	
Check					05/06/2019	1,201.69	
	<u>Q7MB4457</u>	CUST # L10358 AIR FILTER - PARTS PLUS	03/22/2019	05/13/2019	0.00	37.73	
	<u>Q7MB5734</u>	CUST # L10358 FILTER-AIR DOMESTIC	03/26/2019	05/13/2019	0.00	66.90	
	<u>Q7MB6927</u>	CUST # L10358 SUPER CONCENTRATE	03/28/2019	05/13/2019	0.00	91.67	
	<u>Q7MB7601</u>	CUST # L10358 OIL FILTER	03/29/2019	05/13/2019	0.00	3.37	
	<u>Q7MC0727</u>	CUST # L10358 ANCO 31-SERIES	04/05/2019	05/13/2019	0.00	79.24	
	<u>Q7MC2671</u>	CUST # L10358 BENDIX PREM POLICE PADS	04/10/2019	05/13/2019	0.00	241.46	
	<u>Q7MC3445</u>	CUST # L310 HARMONIC BALANCER	04/11/2019	05/13/2019	0.00	113.47	
	<u>Q7MC3946</u>	CUST # L10358 PREMIUM CAPSULE - LONG	04/12/2019	05/13/2019	0.00	11.05	
	<u>Q7MC7776</u>	CUST # L10358 BENDIX BRAKE ROTOR	04/23/2019	05/13/2019	0.00	424.05	
	<u>Q7MC9064</u>	CUST # L10358 AIR FILTER - PARTS PLUS	04/26/2019	05/13/2019	0.00	114.70	
	<u>Q7MC9088</u>	CUST # L10358 AIR FILTER - PARTS PLUS	04/26/2019	05/13/2019	0.00	18.05	

Payment Register

Vendor Number	Vendor Name						Total Vendor Amount
<u>CARSER</u>	CARD SERVICE CENTER						6,479.27
Payment Type	Payment Number					Payment Date	Payment Amount
Check						05/06/2019	6,479.27
Payable Number	Description	Payable Date	Due Date	Discount Amount	Payable Amount		
<u>40119</u>	CARD ENDS W/1237 APRIL 2019	04/30/2019	05/13/2019	0.00	6,479.27		
<u>CAROHL</u>	CARL R. OHLENDORF INSURANCE						71.00
Payment Type	Payment Number					Payment Date	Payment Amount
Check						05/06/2019	71.00
Payable Number	Description	Payable Date	Due Date	Discount Amount	Payable Amount		
<u>16911</u>	POLICY 72144998 ACCT # CALDW01 AMY T HORNE	04/15/2019	05/13/2019	0.00	71.00		
<u>CENTEX</u>	CENTRAL TEXAS MEDICAL CENTER						483.00
Payment Type	Payment Number					Payment Date	Payment Amount
Check						05/06/2019	483.00
Payable Number	Description	Payable Date	Due Date	Discount Amount	Payable Amount		
<u>106135009</u>	MADYSON ALLEN / PAT # 106135009	02/06/2019	05/13/2019	0.00	483.00		
<u>CENAIR</u>	CENTURY A/C SUPPLY						22.00
Payment Type	Payment Number					Payment Date	Payment Amount
Check						05/06/2019	22.00
Payable Number	Description	Payable Date	Due Date	Discount Amount	Payable Amount		
<u>9752294</u>	ORDER # 6568902 OVAL CAPACITOR	04/17/2019	05/13/2019	0.00	22.00		
<u>SPEBUS</u>	CHARTER COMMUNICATIONS HOLDINGS, LLC						11,407.68
Payment Type	Payment Number					Payment Date	Payment Amount
Check						05/06/2019	11,407.68
Payable Number	Description	Payable Date	Due Date	Discount Amount	Payable Amount		
<u>0000426032819</u>	ACCT # 8260 16 300 0000426 3/02 - 4/30/19	03/28/2019	05/13/2019	0.00	11,407.68		
<u>CINDUR</u>	CINDY A. DURAN						2,555.00
Payment Type	Payment Number					Payment Date	Payment Amount
Check						05/06/2019	2,555.00
Payable Number	Description	Payable Date	Due Date	Discount Amount	Payable Amount		
<u>17-FL-312 4</u>	CAUSE # 17-FL-312 D.C. / E.C.	04/25/2019	05/13/2019	0.00	707.00		
<u>18-FL-503 1</u>	CAUSE # 18-FL-503 A.C./B.C./C.C./D.C.	04/25/2019	05/13/2019	0.00	231.00		
<u>19-FL-027 1</u>	CAUSE # 19-FL-027 G.H.G / A.J.C.	04/25/2019	05/13/2019	0.00	294.00		
<u>19-FL-086</u>	CAUSE # 19-FL-086 D.L./F.L./M.L.	04/25/2019	05/13/2019	0.00	350.00		
<u>19-FL-146</u>	CAUSE # 19-FL-146 C.E.J.	04/25/2019	05/13/2019	0.00	973.00		
<u>CINTAS</u>	CINTAS CORPORATION #86						4,788.31
Payment Type	Payment Number					Payment Date	Payment Amount
Check						05/06/2019	4,788.31
Payable Number	Description	Payable Date	Due Date	Discount Amount	Payable Amount		
<u>3112019 CORRECTION</u>	REPAY 4008458845 & 4008458887 NOVEMBER 2018	03/11/2019	05/13/2019	0.00	833.29		
<u>4008458887 CORRECTION</u>	SOLD TO # 13232664 SHOULD NOT HAVE TAKEN CREDIT	09/19/2018	05/13/2019	0.00	470.99		
<u>4016239308 C</u>	OVERPAYMENT ON STATEMENT DATED 3/31/19	02/06/2019	02/06/2019	0.00	-2.21		
<u>4016593352 C</u>	OVERPAYMENT STATEMENT DATED 3-31-19	02/13/2019	02/13/2019	0.00	-64.41		
<u>4018975653</u>	SOLD TO # 13228013 PAYER # 13242157	03/27/2019	05/13/2019	0.00	81.02		
<u>4019388191</u>	SOLD TO # 13232687 PAYER # 13243034	04/03/2019	05/13/2019	0.00	139.36		
<u>4019388196</u>	SOLD TO # 13228849 PAYER # 13243034	04/03/2019	05/13/2019	0.00	321.89		
<u>4019388205</u>	SOLD TO: 13232664 PAYER # 13243034	04/03/2019	05/13/2019	0.00	212.70		
<u>4019388343</u>	SOLD TO # 13228085 PAYER # 13242165	04/03/2019	05/13/2019	0.00	68.70		
<u>4019388436</u>	SOLD TO # 13228013 PAYER # 13242157	04/03/2019	05/13/2019	0.00	81.02		
<u>4019800536</u>	SOLD TO # 13232664 PAYER # 13243034	04/10/2019	05/13/2019	0.00	212.70		

Payment Register

APPKT03083 - 5/13/19 A/P RUN

<u>4019800558</u>	SOLD TO # 13228849 PAYER # 13243034	04/10/2019	05/13/2019	0.00	321.89
<u>4019800574</u>	SOLD TO: 13232687 PAYER # 13243034	04/10/2019	05/13/2019	0.00	141.61
<u>4019800689</u>	SOLD TO # 13228085 PAYER # 13242165	04/10/2019	05/13/2019	0.00	76.69
<u>4019800797</u>	SOLD TO # 13228013 PAYER # 13242157	04/10/2019	05/13/2019	0.00	81.02
<u>4020224641</u>	SOLD TO # 13232664 PAYER # 13243034	04/17/2019	05/13/2019	0.00	216.70
<u>4020224680</u>	SOLD TO # 13228849 PAYER # 13243034	04/17/2019	05/13/2019	0.00	345.62
<u>4020224724</u>	SOLD TO # 13232687 PAYER # 13243034	04/17/2019	05/13/2019	0.00	139.36
<u>4020224869</u>	SOLD TO # 13228085 PAYER # 13242165	04/17/2019	05/13/2019	0.00	76.69
<u>4020224942</u>	SOLD TO # 13228013 PAYER # 13242157 BLDG M	04/17/2019	05/13/2019	0.00	81.02
<u>4020645448</u>	SOLD TO # 13228085 PAYER # 13242165	04/24/2019	05/13/2019	0.00	76.69
<u>4020645464</u>	SOLD # 13232687 PAYER # 13243034	04/24/2019	05/13/2019	0.00	139.36
<u>4020645465</u>	SOLD TO # 13232664 PAYER # 13243034	04/24/2019	05/13/2019	0.00	212.70
<u>4020645476</u>	SOLD TO # 13228849 PAYER # 13243034	04/24/2019	05/13/2019	0.00	345.62
<u>4020645519</u>	SOLD TO # 13228013 PAYER # 13242157 BUILDING M	04/24/2019	05/13/2019	0.00	81.02
<u>4021073586</u>	SOLD TO# 13228013 PAYER # 13242157	05/01/2019	05/13/2019	0.00	97.27

Vendor Number Vendor Name Total Vendor Amount
COLWIS COLIN WISE 250.00

Payment Type	Payment Number	Payment Date	Payment Amount
Check		05/06/2019	250.00
Payable Number	Description	Payable Date	Due Date
<u>45698</u>	CAUSE # 45698 EZEKIAL LEE GARCIA	03/20/2019	05/13/2019
		Discount Amount	Payable Amount
		0.00	250.00

Vendor Number Vendor Name Total Vendor Amount
COTSAF COTHRON'S SAFE & LOCK 199.70

Payment Type	Payment Number	Payment Date	Payment Amount
Check		05/06/2019	199.70
Payable Number	Description	Payable Date	Due Date
<u>1221851</u>	CUST # CALD119 SERVICE CALL / CODE TO MASTER TAX	04/23/2019	05/13/2019
		Discount Amount	Payable Amount
		0.00	199.70

Vendor Number Vendor Name Total Vendor Amount
DALAYE DALTON GENE AYERS 110.00

Payment Type	Payment Number	Payment Date	Payment Amount
Check		05/06/2019	110.00
Payable Number	Description	Payable Date	Due Date
<u>41119</u>	22 HOG TAILS	04/11/2019	05/13/2019
		Discount Amount	Payable Amount
		0.00	110.00

Vendor Number Vendor Name Total Vendor Amount
DANMCC DAN MCCORMACK 1,850.00

Payment Type	Payment Number	Payment Date	Payment Amount
Check		05/06/2019	1,850.00
Payable Number	Description	Payable Date	Due Date
<u>46,128</u>	CAUSE # 46,128 JEYLAN ELLIS	03/20/2019	05/13/2019
<u>47,002</u>	CAUSE # 47,002 LAMORA LOUISE WILLIAMS	03/21/2019	05/13/2019
<u>47,116</u>	CAUSE # 47,116 JAMES CHARLES CERVANTES	03/21/2019	05/13/2019
		Discount Amount	Payable Amount
		0.00	800.00

Vendor Number Vendor Name Total Vendor Amount
DARLAW DARLA LAW 236.64

Payment Type	Payment Number	Payment Date	Payment Amount
Check		05/06/2019	236.64
Payable Number	Description	Payable Date	Due Date
<u>42019</u>	MILEAGE FOR APRIL 2019	04/30/2019	05/13/2019
		Discount Amount	Payable Amount
		0.00	236.64

Vendor Number Vendor Name Total Vendor Amount
DAVMUS DAVID A MUSICK 80.00

Payment Type	Payment Number	Payment Date	Payment Amount
Check		05/06/2019	80.00
Payable Number	Description	Payable Date	Due Date
<u>41119</u>	16 TAILS	04/11/2019	05/13/2019
		Discount Amount	Payable Amount
		0.00	80.00

Payment Register

Vendor Number	Vendor Name						Total Vendor Amount
<u>DAVBRO</u>	DAVID BROOKS, ATTORNEY AT LAW						100.00
Payment Type	Payment Number					Payment Date	Payment Amount
Check						05/06/2019	100.00
Payable Number	Description	Payable Date	Due Date	Discount Amount	Payable Amount		
<u>42019</u>	LEGAL CONSULTATION SERVICES APRIL 2019	04/29/2019	05/13/2019	0.00	100.00		
<u>DAVIMEN</u>	DAVID MENDOZA						450.00
Payment Type	Payment Number					Payment Date	Payment Amount
Check						05/06/2019	450.00
Payable Number	Description	Payable Date	Due Date	Discount Amount	Payable Amount		
<u>45710</u>	CAUSE # 45710 BRYAN BUSTILLO	03/20/2019	05/13/2019	0.00	450.00		
<u>DEAELE</u>	DEALERS ELECTRIC						1,734.75
Payment Type	Payment Number					Payment Date	Payment Amount
Check						05/06/2019	1,734.75
Payable Number	Description	Payable Date	Due Date	Discount Amount	Payable Amount		
<u>1858263-01</u>	CUST # 134031 IOTA I-32 TBTS PLUS FRT	03/06/2019	05/13/2019	0.00	643.69		
<u>1858639-01</u>	CUST # 134031 IOTA I-420-EM-R	03/18/2019	05/13/2019	0.00	984.00		
<u>1859310-00</u>	CUST # 134031 TRANSPORATION & HANDLING HOLDING	03/19/2019	05/13/2019	0.00	107.06		
<u>DELPRA</u>	DEL PRADO-DIETZ,PLLC						1,500.00
Payment Type	Payment Number					Payment Date	Payment Amount
Check						05/06/2019	1,500.00
Payable Number	Description	Payable Date	Due Date	Discount Amount	Payable Amount		
<u>46641</u>	CAUSE # 46641 ALEXIS MCGIRTY	03/21/2019	05/13/2019	0.00	1,500.00		
<u>DENENG</u>	DENNIS ENGELKE						177.83
Payment Type	Payment Number					Payment Date	Payment Amount
Check						05/06/2019	177.83
Payable Number	Description	Payable Date	Due Date	Discount Amount	Payable Amount		
<u>42019</u>	TRAVEL FOR 4/2 - 29/19	05/01/2019	05/13/2019	0.00	177.83		
<u>DEWPOT</u>	DEWITT POTH & SON						2,462.89
Payment Type	Payment Number					Payment Date	Payment Amount
Check						05/06/2019	2,462.89
Payable Number	Description	Payable Date	Due Date	Discount Amount	Payable Amount		
<u>555374-0</u>	CUST # 12430 PLANNER, MONTHLY, DESK,	11/26/2018	05/13/2019	0.00	87.16		
<u>558499-0</u>	CUST # 12430 ENVELOPE, CLASP, XTRAH BX	12/31/2018	05/13/2019	0.00	39.24		
<u>567411-0</u>	CUST # 12430 FOLDER, FILE, LTR	03/26/2019	05/13/2019	0.00	49.70		
<u>567469-0</u>	CUST # 12430 CHAIR, MESH, MIDBACK,B	04/22/2019	05/13/2019	0.00	425.69		
<u>568792-0</u>	CUST # 12430 SPOTPAPER	04/10/2019	05/13/2019	0.00	316.39		
<u>568893-0</u>	CUST # 12430 BOX, SECURITY, FIRE-RE	04/10/2019	05/13/2019	0.00	16.13		
<u>568893-1</u>	CUST # 12430 BOX, SECURITY, FIRE RE	04/11/2019	05/13/2019	0.00	48.45		
<u>568998-0</u>	CUST # 12430 WALLET, 2", ANTIMCRB, L	04/11/2019	05/13/2019	0.00	102.63		
<u>569000-0</u>	CUST # 12430 SPOTPAPER - LETTER	04/11/2019	05/13/2019	0.00	144.00		
<u>569237-0</u>	CUST # 12430 PAD, EASEL, SLFSTCK, PL CT	04/12/2019	05/13/2019	0.00	85.73		
<u>569461-0</u>	CUST # 12430 MARKER, PERMANENT, FIN	04/16/2019	05/13/2019	0.00	115.78		
<u>569516-0</u>	CUST # 12430 RACK, DSPLY, LIT, 11PKT	04/16/2019	05/13/2019	0.00	172.59		
<u>569546-0</u>	CUST # 12430 TRIMMER, CLSCPRO, WOOD	04/17/2019	05/13/2019	0.00	172.55		
<u>569684-0</u>	CUST # 12430 CRTDG, INKJET, HP951XL EA	04/18/2019	05/13/2019	0.00	33.99		
<u>569834-0</u>	CUST # 12430 FASTENER, COMPRSR	04/22/2019	05/13/2019	0.00	272.75		
<u>569834-1</u>	CUST # 12430 TISSUES, ANTIVIRAL, KL CT	04/24/2019	05/13/2019	0.00	43.49		
<u>570081-0</u>	CUST # 12430 FOLDER, FILE, LTR, 1/3,	04/24/2019	05/13/2019	0.00	56.80		
<u>570271-0</u>	CUST # 12430 BOARD, CORK, ALUMFRM	04/25/2019	05/13/2019	0.00	54.66		
<u>570274-0</u>	CUST # 12430 FOLDER, INTERIOR, LTR	04/25/2019	05/13/2019	0.00	193.60		

Payment Register

APPKT03083 - 5/13/19 A/P RUN

<u>570345-0</u>	SYSTEM # 8299 SERIAL # C2C228580	04/26/2019	05/13/2019	0.00	31.56
Vendor Number	Vendor Name				Total Vendor Amount
<u>DOBSUP</u>	DOBIE SUPPLY, LLC				673.00
Payment Type	Payment Number	Payment Date	Payment Amount		
Check		05/06/2019	673.00		
Payable Number	Description	Payable Date	Due Date	Discount Amount	Payable Amount
<u>22625</u>	18" X 24" HIM PRINTED SIGN WITH UV OVERLAY ON .08C	04/23/2019	05/13/2019	0.00	673.00
Vendor Number	Vendor Name				Total Vendor Amount
<u>E&RSUP</u>	E & R SUPPLY CO., INC				117.62
Payment Type	Payment Number	Payment Date	Payment Amount		
Check		05/06/2019	117.62		
Payable Number	Description	Payable Date	Due Date	Discount Amount	Payable Amount
<u>216219</u>	ACCT # 23750 STR. F. SAE37 SW/VEL E	04/30/2019	05/13/2019	0.00	117.62
Vendor Number	Vendor Name				Total Vendor Amount
<u>ELGVET</u>	ELGIN VETERINARY HOSPITAL, INC				380.90
Payment Type	Payment Number	Payment Date	Payment Amount		
Check		05/06/2019	380.90		
Payable Number	Description	Payable Date	Due Date	Discount Amount	Payable Amount
<u>41119</u>	EQ ACCOUNT # 53123 3/1 - 4/15/19	04/15/2019	05/13/2019	0.00	380.90
Vendor Number	Vendor Name				Total Vendor Amount
<u>ELSLAC</u>	ELSIE LACY				124.12
Payment Type	Payment Number	Payment Date	Payment Amount		
Check		05/06/2019	124.12		
Payable Number	Description	Payable Date	Due Date	Discount Amount	Payable Amount
<u>32019</u>	LEARN, GROW, EAT & GO PLISD, 4-H PURCHASING/ FOOI	04/16/2019	05/13/2019	0.00	124.12
Vendor Number	Vendor Name				Total Vendor Amount
<u>EMINIE</u>	EMIL NIEMANN				180.00
Payment Type	Payment Number	Payment Date	Payment Amount		
Check		05/06/2019	180.00		
Payable Number	Description	Payable Date	Due Date	Discount Amount	Payable Amount
<u>41119</u>	36 HOG TAILS	04/11/2019	05/13/2019	0.00	180.00
Vendor Number	Vendor Name				Total Vendor Amount
<u>FARBRO</u>	FARMER BROTHERS. CO.				808.52
Payment Type	Payment Number	Payment Date	Payment Amount		
Check		05/06/2019	808.52		
Payable Number	Description	Payable Date	Due Date	Discount Amount	Payable Amount
<u>69005340</u>	ACCT # 6302473 BLACK SWT FLPK 4 OZ / 24 CT	04/09/2019	05/13/2019	0.00	357.76
<u>69039709</u>	ACCT # 6302473/6302473 ICETEA BLACK SWT FLPK	04/23/2019	05/13/2019	0.00	450.76
Vendor Number	Vendor Name				Total Vendor Amount
<u>FERJOS</u>	FERRIS JOSEPH PRODUCE, INC.				2,431.23
Payment Type	Payment Number	Payment Date	Payment Amount		
Check		05/06/2019	2,431.23		
Payable Number	Description	Payable Date	Due Date	Discount Amount	Payable Amount
<u>108077</u>	ICEBERG 24 CT	03/30/2019	05/13/2019	0.00	96.00
<u>108082</u>	ICEBERG 24 CT	04/01/2019	05/13/2019	0.00	91.00
<u>108092</u>	BANANAS EA	04/02/2019	05/13/2019	0.00	86.10
<u>108123</u>	RED CABBAGE LB	04/04/2019	05/13/2019	0.00	112.80
<u>108128</u>	AA MED 15 DOZ EGGS	04/05/2019	05/13/2019	0.00	194.25
<u>108177</u>	BANANAS EA	04/06/2019	05/13/2019	0.00	178.00
<u>108188</u>	BANANAS EA	04/08/2019	05/13/2019	0.00	91.50
<u>108195</u>	ICEBERG 24 CT	04/09/2019	05/13/2019	0.00	70.00
<u>108207</u>	POTATOES 5/10 LB BAGGED RUSSETS	04/10/2019	05/13/2019	0.00	100.50
<u>108220</u>	CELERY EA	04/11/2019	05/13/2019	0.00	158.28
<u>108237</u>	AA MED 15 DOZ EGGS	04/12/2019	05/13/2019	0.00	192.10
<u>108292</u>	POTATOES 5810 LB BAGGED RUSSETS	04/13/2019	05/13/2019	0.00	29.00

Payment Register

APPKT03083 - 5/13/19 A/P RUN

Invoice #	Item Description	Invoice Date	Due Date	Amount	Balance
<u>108309</u>	BANANAS 40 LB CASE	04/16/2019	05/13/2019	0.00	145.50
<u>108316</u>	ICEBERG 24 CT	04/17/2019	05/13/2019	0.00	37.00
<u>108332</u>	ICEBERG 24 CT	04/18/2019	05/13/2019	0.00	105.50
<u>108337</u>	GREEN CABBAGE LB	04/19/2019	05/13/2019	0.00	185.30
<u>108391</u>	APPLES 138CT RED DEL CASE	04/20/2019	05/13/2019	0.00	92.00
<u>108406</u>	CABBAGE GREEN 50 LB JBO SACK	04/23/2019	05/13/2019	0.00	90.00
<u>108418</u>	50 LB JUMBO YELLOW ONIONS	04/24/2019	05/13/2019	0.00	50.50
<u>108435</u>	ICEBERG 24 CT	04/25/2019	05/13/2019	0.00	99.50
<u>108439</u>	ICEBERG 24 CT	04/26/2019	05/13/2019	0.00	226.40

Vendor Number	Vendor Name	Total Vendor Amount
<u>FILSYS</u>	FILEX SYSTEMS, INC	583.00
Payment Type	Payment Number	Payment Date Payment Amount
Check		05/06/2019 583.00
Payable Number	Description	Payable Date Due Date Discount Amount Payable Amount
<u>99542</u>	FILEX PO# 99169 LEGAL RED TOP TAB PRINT FORM 27	04/15/2019 05/13/2019 0.00 583.00

Vendor Number	Vendor Name	Total Vendor Amount
<u>FUEMAN</u>	FLEETCOR TECHNOLOGIES, INC	16,266.25
Payment Type	Payment Number	Payment Date Payment Amount
Check		05/06/2019 16,266.25
Payable Number	Description	Payable Date Due Date Discount Amount Payable Amount
<u>NP55933650</u>	ACCT # BG114286 3/25 - 4/28/19	04/29/2019 05/13/2019 0.00 16,266.25

Vendor Number	Vendor Name	Total Vendor Amount
<u>FLEPRI</u>	FLEETPRIDE	670.42
Payment Type	Payment Number	Payment Date Payment Amount
Check		05/06/2019 670.42
Payable Number	Description	Payable Date Due Date Discount Amount Payable Amount
<u>24215581</u>	ACCT # 83215 DRAG LINK FORD (EA)	04/04/2019 05/13/2019 0.00 670.42

Vendor Number	Vendor Name	Total Vendor Amount
<u>BUTBAK</u>	FLOWERS BAKING CO. OF SAN ANTONIO	1,311.12
Payment Type	Payment Number	Payment Date Payment Amount
Check		05/06/2019 1,311.12
Payable Number	Description	Payable Date Due Date Discount Amount Payable Amount
<u>2038381797</u>	CUST # 0040078309 MIC 207" FLTOR	04/02/2019 05/13/2019 0.00 306.72
<u>2038382129</u>	CUST # 0040078309 MIC 20 7" FL TOR	04/23/2019 05/13/2019 0.00 315.36
<u>TKT # 2038382017</u>	CUST # 0040078309 MIC 20 7" FL TOR	04/16/2019 05/13/2019 0.00 315.36
<u>TKT #2038381902</u>	CUST # 0040078309 MIC 20 7" FL TOR	04/09/2019 05/13/2019 0.00 373.68

Vendor Number	Vendor Name	Total Vendor Amount
<u>GCPRIINT</u>	G and C Printing Forms	225.65
Payment Type	Payment Number	Payment Date Payment Amount
Check		05/06/2019 225.65
Payable Number	Description	Payable Date Due Date Discount Amount Payable Amount
<u>GC 108460</u>	4000 - 10-24 REG ENVELOPES FOR 22ND, 207TH & 421ST	04/23/2019 05/13/2019 0.00 225.65

Vendor Number	Vendor Name	Total Vendor Amount
<u>GAPOWE</u>	GA POWERS	287.42
Payment Type	Payment Number	Payment Date Payment Amount
Check		05/06/2019 287.42
Payable Number	Description	Payable Date Due Date Discount Amount Payable Amount
<u>34292</u>	PART # SLOAN 111 CLOSET REGAL FLUSH VLV	04/04/2019 05/13/2019 0.00 287.42

Vendor Number	Vendor Name	Total Vendor Amount
<u>GALL'S</u>	GALL'S, LLC	195.92
Payment Type	Payment Number	Payment Date Payment Amount
Check		05/06/2019 195.92
Payable Number	Description	Payable Date Due Date Discount Amount Payable Amount
<u>ORDER # 12849834-1</u>	GALLS TAC FORCE SQUAD TACTICAL PANT	04/19/2019 05/13/2019 0.00 99.96

Payment Register

APPKT03083 - 5/13/19 A/P RUN

ORDER # 12849834-2 65/35 POLY/COTTON S/S TACT SQUAD MILLITAR 04/19/2019 05/13/2019 0.00 95.96

Vendor Number Vendor Name Total Vendor Amount
GEOPAR GEORGE V. C. PARKER 1,500.00

Payment Type Payment Number Payment Date Payment Amount
 Check 17-FL-357 05/06/2019 1,500.00

Payable Number Description Payable Date Due Date Discount Amount Payable Amount
47-426 CAUSE # 47-426 CRESCENTINO "CHRIS" PLAIA 04/24/2019 05/13/2019 0.00 1,500.00

Vendor Number Vendor Name Total Vendor Amount
GLEGRU GLEN A. GRUNBERGER 889.00

Payment Type Payment Number Payment Date Payment Amount
 Check 17-FL-357 05/06/2019 889.00

Payable Number Description Payable Date Due Date Discount Amount Payable Amount
17-FL-357 CAUSE # 17-FL-357 N.T. / A.T. 04/25/2019 05/13/2019 0.00 889.00

Vendor Number Vendor Name Total Vendor Amount
GLEWIL GLENN WILLIAMS 175.00

Payment Type Payment Number Payment Date Payment Amount
 Check 19-FL-086 05/06/2019 175.00

Payable Number Description Payable Date Due Date Discount Amount Payable Amount
19-FL-086 CAUSE # 19-FL-086 D.L. / F.L. & M.L. 04/25/2019 05/13/2019 0.00 175.00

Vendor Number Vendor Name Total Vendor Amount
GONBUI GONZALES BUILDING CENTER 247.13

Payment Type Payment Number Payment Date Payment Amount
 Check INV0791750 05/06/2019 247.13

Payable Number Description Payable Date Due Date Discount Amount Payable Amount
INV0791750 CUST # CALD001 TOWEL MULT-FOLD 1-PLY NATURAL 04/22/2019 05/13/2019 0.00 247.13

Vendor Number Vendor Name Total Vendor Amount
GRAING GRAINGER 1,020.34

Payment Type Payment Number Payment Date Payment Amount
 Check 9129229622 05/06/2019 1,020.34

Payable Number	Description	Payable Date	Due Date	Discount Amount	Payable Amount
<u>9129229622</u>	ACCT # 841505548 FLUORESCENT LINEAR LAMP, T12, CC	03/28/2019	05/13/2019	0.00	111.30
<u>9129770054</u>	ACCT # 841505548 INCANDESCENT LIGHT BULB, T6	03/28/2019	05/13/2019	0.00	146.70
<u>9131634819</u>	ACCT # 841505548 SMOKE DETECTOR TESTER, 2-1/2	03/29/2019	05/13/2019	0.00	34.59
<u>9136155695</u>	ACCT # 841505548 DUPLEX WALL PLATE, 1 GANG, SILVE	04/04/2019	04/04/2019	0.00	-1.30
<u>9141043142</u>	ACCT # 841505548 KNOB LOCKSET, MECHANICAL, STOR	04/09/2019	05/13/2019	0.00	468.14
<u>9142732784</u>	ACCT # 841505548 KNOB LOCKSET, MECHANICAL, PASS	04/10/2019	05/13/2019	0.00	41.82
<u>9149674062</u>	ACCT # 841505548 PLUG, 125VAC, 15A, L1-15P 2P, 2W	04/18/2019	04/18/2019	0.00	-3.27
<u>9150396654</u>	ACCT # 841505548 JOBBER DRILL BIT SET, LIST # 150	04/18/2019	05/13/2019	0.00	222.36

Vendor Number Vendor Name Total Vendor Amount
GRUELE GRUMBLES ELECTRIC CO. 560.00

Payment Type Payment Number Payment Date Payment Amount
 Check 18-1238 05/06/2019 560.00

Payable Number Description Payable Date Due Date Discount Amount Payable Amount
18-1238 TROUBLESHOOT BURNT WALL PACK - BUCKET TRUCK 03/25/2019 05/13/2019 0.00 560.00

Vendor Number Vendor Name Total Vendor Amount
GTDIST GT DISTRIBUTORS, INC. 140.09

Payment Type Payment Number Payment Date Payment Amount
 Check INV070160 05/06/2019 140.09

Payable Number	Description	Payable Date	Due Date	Discount Amount	Payable Amount
<u>INV070160</u>	CUST # 000297 FLEX CUFFS / CUFF CUTTER	03/15/2019	05/13/2019	0.00	122.10
<u>INV0706979</u>	CUST # 006427 CCI .40S&W 50/BX TMJ 165 GR AUSTIN	04/22/2019	05/13/2019	0.00	17.99

Payment Register

Vendor Number	Vendor Name			Total Vendor Amount
<u>H2OPAR</u>	H2O PARTNERS, INC			9,450.00
Payment Type	Payment Number	Payment Date	Payment Amount	
Check		05/06/2019	9,450.00	
Payable Number	Description	Payable Date	Due Date	Discount Amount Payable Amount
<u>113346</u>	CONDUCT HAZARD RESEARCH AND GATHER DATA FOR R	04/15/2019	05/13/2019	0.00 9,450.00

Vendor Number	Vendor Name			Total Vendor Amount
<u>HANEQU</u>	HANSON EQUIPMENT			998.36
Payment Type	Payment Number	Payment Date	Payment Amount	
Check		05/06/2019	998.36	
Payable Number	Description	Payable Date	Due Date	Discount Amount Payable Amount
<u>270842</u>	# CAL001 340/18 TIRE REPAIR	04/03/2019	05/13/2019	0.00 267.21
<u>270874</u>	# CAL001 HANDGUN / EXTENSION 15"	04/04/2019	05/13/2019	0.00 46.63
<u>270895</u>	HOSE -FARMEX II 1/2" 3500PSI	04/05/2019	05/13/2019	0.00 40.61
<u>270945</u>	# CAL001 FLAT TIRE REPAIR	04/08/2019	05/13/2019	0.00 19.34
<u>270974</u>	# CAL001 PUMP FITTING KIT (FIMCO 2.1	04/09/2019	05/13/2019	0.00 11.14
<u>271139</u>	# CAL001 HOSE -FARMEX II 1/4" 5000PSI	04/16/2019	05/13/2019	0.00 37.16
<u>271256</u>	# CAL001 EMBLEM W/STEEL BACK	04/23/2019	05/13/2019	0.00 529.70
<u>271297</u>	# CAL001 FLAT TIRE REPAIR	04/25/2019	05/13/2019	0.00 16.83
<u>271298</u>	# CAL001 TIRE GAUGE-LONG DUAL FOOT	04/25/2019	05/13/2019	0.00 29.74

Vendor Number	Vendor Name			Total Vendor Amount
<u>HERWAR</u>	HERSHELL WARNER			40.00
Payment Type	Payment Number	Payment Date	Payment Amount	
Check		05/06/2019	40.00	
Payable Number	Description	Payable Date	Due Date	Discount Amount Payable Amount
<u>41119</u>	8 TAILS	04/11/2019	05/13/2019	0.00 40.00

Vendor Number	Vendor Name			Total Vendor Amount
<u>HOFSUP</u>	HOFMANN'S SUPPLY			103.84
Payment Type	Payment Number	Payment Date	Payment Amount	
Check		05/06/2019	103.84	
Payable Number	Description	Payable Date	Due Date	Discount Amount Payable Amount
<u>838147</u>	CUST # 01734 ACETYLENE SMALL	04/30/2019	05/13/2019	0.00 103.84

Vendor Number	Vendor Name			Total Vendor Amount
<u>HOTGAL</u>	HOTEL GALVEZ & SPA			285.20
Payment Type	Payment Number	Payment Date	Payment Amount	
Check		05/06/2019	285.20	
Payable Number	Description	Payable Date	Due Date	Discount Amount Payable Amount
<u>CONF # 18896710</u>	TERESA RODRIGUEZ - 5/29 - 31/19	04/25/2019	05/13/2019	0.00 285.20

Vendor Number	Vendor Name			Total Vendor Amount
<u>HOYENT</u>	HOYT ENTERPRISES, INC			250.00
Payment Type	Payment Number	Payment Date	Payment Amount	
Check		05/06/2019	250.00	
Payable Number	Description	Payable Date	Due Date	Discount Amount Payable Amount
<u>045103</u>	PO # JS01-10-19 FLOW TEST CHARGE	04/04/2019	05/13/2019	0.00 250.00

Vendor Number	Vendor Name			Total Vendor Amount
<u>JAMSTO</u>	JAMES F. STONE			390.00
Payment Type	Payment Number	Payment Date	Payment Amount	
Check		05/06/2019	390.00	
Payable Number	Description	Payable Date	Due Date	Discount Amount Payable Amount
<u>41119</u>	78 HOG TAILS	04/11/2019	05/13/2019	0.00 390.00

Payment Register

APPKT03083 - 5/13/19 A/P RUN

Vendor Number	Vendor Name						Total Vendor Amount
<u>JAMREE</u>	JAMES HARLON REED						40.00
Payment Type	Payment Number					Payment Date	Payment Amount
Check						05/06/2019	40.00
Payable Number	Description	Payable Date	Due Date	Discount Amount	Payable Amount		
<u>41119</u>	8 TAILS	04/11/2019	05/13/2019	0.00	40.00		
<u>JANMUS</u>	JAN FORD MUSTIN PH.D, P.C.						590.00
Payment Type	Payment Number					Payment Date	Payment Amount
Check						05/06/2019	590.00
Payable Number	Description	Payable Date	Due Date	Discount Amount	Payable Amount		
<u>04252019</u>	TCOLE EVALUATION, MMPI RICHARDSON, TRENTON	04/25/2019	05/13/2019	0.00	295.00		
<u>04262019</u>	TCOLE EVALUATION, MMPI LOWE, KAITLYN	04/26/2019	05/13/2019	0.00	295.00		
<u>JANWIL</u>	JANA CLIFT-WILLIAMS						1,414.00
Payment Type	Payment Number					Payment Date	Payment Amount
Check						05/06/2019	1,414.00
Payable Number	Description	Payable Date	Due Date	Discount Amount	Payable Amount		
<u>18-FL-192_6</u>	CAUSE # 18-FL-192 R.G.	04/25/2019	05/13/2019	0.00	119.00		
<u>18-FL-309_4</u>	CAUSE # 18-FL-309 Z.R.	04/25/2019	05/13/2019	0.00	70.00		
<u>18-FL-448_5</u>	CAUSE # 18-FL-448 P.G /J.G.	04/25/2019	05/13/2019	0.00	399.00		
<u>18-FL-488_4</u>	CAUSE # 18-FL-488 A.E.	04/26/2019	05/13/2019	0.00	77.00		
<u>18-FL-539_2</u>	CAUSE # 18-FL-539 N.M.	04/25/2019	05/13/2019	0.00	266.00		
<u>18-FL-595_2</u>	CAUSE # 18-FL-595 L.G.	04/25/2019	05/13/2019	0.00	105.00		
<u>19-FL-054_1</u>	CAUSE # 19-FL-054 D.R.	04/25/2019	05/13/2019	0.00	182.00		
<u>19-FL-086</u>	CAUSE # 19-FL-086 D.L.	04/25/2019	05/13/2019	0.00	77.00		
<u>19-FL-091</u>	CAUSE # 19-FL-091 J.S.	04/25/2019	05/13/2019	0.00	119.00		
<u>JOESMI</u>	Joe Smith						40.00
Payment Type	Payment Number					Payment Date	Payment Amount
Check						05/06/2019	40.00
Payable Number	Description	Payable Date	Due Date	Discount Amount	Payable Amount		
<u>41119</u>	8 TAILS	04/11/2019	05/13/2019	0.00	40.00		
<u>FARPLA</u>	JOHN DEERE FINANCIAL						236.52
Payment Type	Payment Number					Payment Date	Payment Amount
Check						05/06/2019	236.52
Payable Number	Description	Payable Date	Due Date	Discount Amount	Payable Amount		
<u>1903-009852</u>	ACCT # 1-99 ROOFING - 26A R PANEL	03/29/2019	05/13/2019	0.00	16.40		
<u>1904-012010</u>	ACCT # 1-99 HOE GARDEN WOOD ACE	04/02/2019	05/13/2019	0.00	19.99		
<u>1904-018068</u>	ACCT # 1-99 SCREWDRIVER SET 6 PC ACE	04/10/2019	05/13/2019	0.00	113.31		
<u>1904-028325</u>	ACCT # 1-99 10 X 3/4 PHILLIP FLAT SMS	04/25/2019	05/13/2019	0.00	28.50		
<u>1904-030979</u>	ACCT # 1-99 SPRAY PAINT 2X BLACK PRIMER	04/29/2019	05/13/2019	0.00	58.32		
<u>JOHPAI</u>	JOHNNY & SON'S, LLC						5,025.69
Payment Type	Payment Number					Payment Date	Payment Amount
Check						05/06/2019	5,025.69
Payable Number	Description	Payable Date	Due Date	Discount Amount	Payable Amount		
<u>RO # 17396</u>	LICENSE # 108-8154 VIN # 3GCEC13099G2662052009 CH	04/10/2019	05/13/2019	0.00	5,025.69		
<u>KARSPPH</u>	KAREN SPHAR						37.12
Payment Type	Payment Number					Payment Date	Payment Amount
Check						05/06/2019	37.12
Payable Number	Description	Payable Date	Due Date	Discount Amount	Payable Amount		
<u>32519</u>	MILEAGE FOR 3/25/19	05/02/2019	05/13/2019	0.00	37.12		

Payment Register

Vendor Number	Vendor Name					Total Vendor Amount
<u>KEYROB</u>	KEYLA ROBERTSON					3,969.00
Payment Type	Payment Number				Payment Date	Payment Amount
Check					05/06/2019	3,969.00
Payable Number	Description	Payable Date	Due Date	Discount Amount	Payable Amount	
<u>13-FL-183</u>	CAUSE # 13-FL-183 E.L.	04/25/2019	05/13/2019	0.00	1,162.00	
<u>18-FL-488</u>	CAUSE # 18-FL-488 A.E.	04/25/2019	05/13/2019	0.00	595.00	
<u>19-FL-074</u>	CAUSE # 19-FL-074 A.S.	04/25/2019	05/13/2019	0.00	539.00	
<u>1-FL-104</u>	CAUSE # 19-FL-104 D.S.	04/25/2019	05/13/2019	0.00	1,673.00	
<u>LASSIG</u>	LARRY D. RIVERA					214.59
Payment Type	Payment Number				Payment Date	Payment Amount
Check					05/06/2019	214.59
Payable Number	Description	Payable Date	Due Date	Discount Amount	Payable Amount	
<u>EMT-20851</u>	5.00 FT X 6.00 FT PREMIUM AIR RELEASE DIGIAL PRINT	04/16/2019	05/13/2019	0.00	214.59	
<u>LARRAS</u>	LARRY O. RASCO					1,135.00
Payment Type	Payment Number				Payment Date	Payment Amount
Check					05/06/2019	1,135.00
Payable Number	Description	Payable Date	Due Date	Discount Amount	Payable Amount	
<u>18-FL-070</u>	CAUSE # 18-FL-070 A.W.	04/26/2019	05/13/2019	0.00	910.00	
<u>18-FL-474</u>	CAUSE # 18-FL-474 J. CHILDREN	04/25/2019	05/13/2019	0.00	225.00	
<u>LEABUR</u>	LEANE BURT					40.00
Payment Type	Payment Number				Payment Date	Payment Amount
Check					05/06/2019	40.00
Payable Number	Description	Payable Date	Due Date	Discount Amount	Payable Amount	
<u>41119</u>	8 TAILS	04/11/2019	05/13/2019	0.00	40.00	
<u>LEGTRI</u>	LEGENDS TRI-COUNTY FUNERAL SERVICES					300.00
Payment Type	Payment Number				Payment Date	Payment Amount
Check					05/06/2019	300.00
Payable Number	Description	Payable Date	Due Date	Discount Amount	Payable Amount	
<u>2019/050</u>	HUNTER COKE DOT: 3/26/19 JP # 3	03/31/2019	05/13/2019	0.00	300.00	
<u>LELMOR</u>	LELTON WAYNE MORSE					312.33
Payment Type	Payment Number				Payment Date	Payment Amount
Check					05/06/2019	312.33
Payable Number	Description	Payable Date	Due Date	Discount Amount	Payable Amount	
<u>42019</u>	EXPENSE FORM FOR 4/12 -13/19	04/24/2019	05/13/2019	0.00	312.33	
<u>THOLEO</u>	LEON TRANSLATIONS					160.00
Payment Type	Payment Number				Payment Date	Payment Amount
Check					05/06/2019	160.00
Payable Number	Description	Payable Date	Due Date	Discount Amount	Payable Amount	
<u>19267</u>	CAUSE # 13-FL-313 SPANISH INTERPRETATION	01/17/2019	05/13/2019	0.00	160.00	
<u>LILFOR</u>	LILIANA LEON FORES					535.00
Payment Type	Payment Number				Payment Date	Payment Amount
Check					05/06/2019	535.00
Payable Number	Description	Payable Date	Due Date	Discount Amount	Payable Amount	
<u>18-172</u>	CAUSE # 18-172 RAY GONZALES	04/24/2019	05/13/2019	0.00	535.00	

Payment Register

Vendor Number	Vendor Name			Total Vendor Amount	
<u>LIVFEE</u>	LIVENGOOD FEED STORE			214.47	
Payment Type	Payment Number	Payment Date	Payment Amount		
Check		05/06/2019	214.47		
Payable Number	Description	Payable Date	Due Date	Discount Amount	Payable Amount
<u>LOINV000184020</u>	CUST # 1C250	03/30/2019	05/13/2019	0.00	161.97
<u>LOINV000185185</u>	CUST # 1C250 HAY COASTAL SQUARE	04/19/2019	05/13/2019	0.00	52.50

Vendor Number	Vendor Name			Total Vendor Amount	
<u>LOCTRU</u>	LOCKHART HARDWARE			2,216.10	
Payment Type	Payment Number	Payment Date	Payment Amount		
Check		05/06/2019	2,216.10		
Payable Number	Description	Payable Date	Due Date	Discount Amount	Payable Amount
<u>27935 /1</u>	CUST # 11239 STOP & WASTE VALVE 3/4"	03/26/2019	05/13/2019	0.00	25.79
<u>27939 /1</u>	CUST # 11239 HURRICANE TIE ZMAX H1Z	03/26/2019	05/13/2019	0.00	28.88
<u>27946 /1</u>	CUST # 11239 3/8 CDX PINE PLYWOOD	03/26/2019	05/13/2019	0.00	13.99
<u>27963 /1</u>	CUST # 11239 RECIP SAW BLD 6" 8TPI	03/27/2019	05/13/2019	0.00	11.99
<u>27969 /1</u>	CUST # 11239 PVC PIPE SCH40 4" X 2'	03/27/2019	05/13/2019	0.00	49.02
<u>27970 /1</u>	CUST # 11239 SCREWS, NUTS, & BOLTS	03/27/2019	05/13/2019	0.00	24.66
<u>27981 /1</u>	CUST # 11239 4X5 SCH40PVC DWV PIPE	03/28/2019	05/13/2019	0.00	40.57
<u>27983 /1</u>	CUST # 11239 ELBOW 90L PVC DWV 4" HXH	03/28/2019	05/13/2019	0.00	56.89
<u>27987 /1</u>	CUST # 11239 ADAPTR 1/2MPT SCH40 10PK	03/28/2019	05/13/2019	0.00	8.57
<u>28030 /1</u>	CUST # 11239 POLYSHADE, 5PT SAT MAHOGY	04/01/2019	05/13/2019	0.00	14.58
<u>28040 /1</u>	CUST # 11239 JIG BLD 3-5/8" 21TPI 3PK	04/01/2019	05/13/2019	0.00	44.91
<u>28049 /1</u>	CUST # 11239 COMPACT BATTERY 20V	04/02/2019	05/13/2019	0.00	89.98
<u>28060 /1</u>	CUST # 11239 SCREWS, NUTS, & BOLTS	04/02/2019	05/13/2019	0.00	13.53
<u>28072 /1</u>	CUST # 11239 TOILET SEAT ELNG PREM WH	04/03/2019	05/13/2019	0.00	25.98
<u>28113 /1</u>	CUST # 11239 CONCRETE CRACK FILLR	04/05/2019	05/13/2019	0.00	9.99
<u>28144 /1</u>	CUST # 11239 LIQTITE FIT 90D 3/4" PL	04/08/2019	05/13/2019	0.00	45.52
<u>28166 /1</u>	CUST # 11239 ACE ANGLE POLY BRUSH 1"	04/09/2019	05/13/2019	0.00	4.59
<u>28184 /1</u>	CUST # 11239 HVY DUTY CABLE TIE 18"	04/10/2019	05/13/2019	0.00	14.98
<u>28203 /1</u>	CUST # 11239 RYL EXT SAT LTX WHT GL	04/11/2019	05/13/2019	0.00	111.87
<u>28213 /1</u>	CUST # 11239 SPRYPNT DUAL BLACK	04/11/2019	05/13/2019	0.00	62.30
<u>28219 /1</u>	CUST # 11239 ACE PAINT BRUSH 1" FLAT	04/12/2019	05/13/2019	0.00	47.75
<u>28247 /1</u>	CUST # 11239 CORD EXT 12/3 STW 2'	04/15/2019	05/13/2019	0.00	22.76
<u>28264 /1</u>	CUST # 11239 SCREWS, NUTS & BOLTS	04/16/2019	05/13/2019	0.00	26.58
<u>28270 /1</u>	CUST # 11239 MS170 1.9CI W/16" B/C	04/16/2019	05/13/2019	0.00	479.97
<u>28274 /1</u>	CUST # 11239 ROLLER FRAMES 3" 4 WIRE LNZR	04/16/2019	05/13/2019	0.00	173.80
<u>28291 /1</u>	CUST # 11239 SANDPAPR ALOX9X11 CRS4PK	04/17/2019	05/13/2019	0.00	9.18
<u>28319 /1</u>	CUST # 11239 MS170 1.9CI W/16" B/C	04/18/2019	05/13/2019	0.00	468.91
<u>28325 /1</u>	CUST # 11239 DOWEL FSC 5/16 X 48" YELLOW	04/18/2019	05/13/2019	0.00	2.78
<u>28345 /1</u>	CUST # 11239 RYL EXT SAT LTX WHT GL	04/22/2019	05/13/2019	0.00	30.99
<u>28350 /1</u>	CUST # 11239 16" .050" LAM CHAINSAW BAR	04/22/2019	05/13/2019	0.00	34.96
<u>28368 /1</u>	CUST # 11239 SCREWS, NUTS & BOLTS	04/23/2019	05/13/2019	0.00	51.03
<u>28371 /1</u>	CUST # 11239 HEFTY BAG 30 GAL 25CTFLEX	04/23/2019	05/13/2019	0.00	19.98
<u>28379 /1</u>	CUST # 11239 SCREWS, NUTS, & BOLTS	04/23/2019	05/13/2019	0.00	21.97
<u>28399 /1</u>	CUST # 11239 SILICONE I W&D CLR 10.1 OZ	04/24/2019	05/13/2019	0.00	21.97
<u>28423 /1</u>	CUST # 11239 MARKING PAINT ALRTORG	04/26/2019	05/13/2019	0.00	58.90
<u>28424 /1</u>	CUST # 11239 71 PM3 PICCOMICRO CHN	04/26/2019	05/13/2019	0.00	45.98

Vendor Number	Vendor Name			Total Vendor Amount	
<u>LOCMOT</u>	LOCKHART MOTOR CO.,INC.			550.89	
Payment Type	Payment Number	Payment Date	Payment Amount		
Check		05/06/2019	550.89		
Payable Number	Description	Payable Date	Due Date	Discount Amount	Payable Amount
<u>T45482</u>	CUST # 3810 CONTROL	04/23/2019	05/13/2019	0.00	34.80
<u>T45488</u>	CUST # 3810 SENSOR - EXHAUST GAS	04/23/2019	05/13/2019	0.00	516.09

Payment Register

Vendor Number	Vendor Name					Total Vendor Amount
<u>LOCPOS</u>	LOCKHART POST REGISTER					101.32
Payment Type	Payment Number			Payment Date	Payment Amount	
Check				05/06/2019	101.32	
Payable Number	Description	Payable Date	Due Date	Discount Amount	Payable Amount	
<u>00087003</u>	04/04 & 11/19 FOUND	04/15/2019	05/13/2019	0.00	27.88	
<u>00087005</u>	04/04 & 11/19 TELECOMMUCIATOR WANTED	04/15/2019	05/13/2019	0.00	56.44	
<u>00087230</u>	04/18 & 25/19 FOUND	04/25/2019	05/13/2019	0.00	17.00	

Vendor Number	Vendor Name					Total Vendor Amount
<u>LULCHE</u>	LULING CHEVROLET					497.55
Payment Type	Payment Number			Payment Date	Payment Amount	
Check				05/06/2019	497.55	
Payable Number	Description	Payable Date	Due Date	Discount Amount	Payable Amount	
<u>101621</u>	CUST # 1507 PANEL	04/16/2019	05/13/2019	0.00	497.55	

Vendor Number	Vendor Name					Total Vendor Amount
<u>JCOJAN</u>	M.B. HAMMO ENTERPRISES, LLC					2,867.51
Payment Type	Payment Number			Payment Date	Payment Amount	
Check				05/06/2019	2,867.51	
Payable Number	Description	Payable Date	Due Date	Discount Amount	Payable Amount	
<u>6574</u>	TOILET PAPER REGULAR / ROSES	04/18/2019	05/13/2019	0.00	751.40	
<u>6596</u>	TOILET PAPER REGULAR / ROSES	04/10/2019	05/13/2019	0.00	773.21	
<u>6600</u>	36" BLACK TAMPICO PUSH BROOM-MEDIUM BRISTLE	04/10/2019	05/13/2019	0.00	104.70	
<u>6621</u>	TOILET PAPER REGULAR / ROSES	04/17/2019	05/13/2019	0.00	575.83	
<u>6656</u>	TOILET PAPER REGULAR / ROSES	04/24/2019	05/13/2019	0.00	662.37	

Vendor Number	Vendor Name					Total Vendor Amount
<u>NEQFUN</u>	MAILROOM FINANCE, INC					4,891.13
Payment Type	Payment Number			Payment Date	Payment Amount	
Check				05/06/2019	212.30	
Payable Number	Description	Payable Date	Due Date	Discount Amount	Payable Amount	
<u>41119</u>	ACCT # 7900 0440 8052 6951	04/11/2019	05/13/2019	0.00	212.30	
Check				05/06/2019	470.67	
Payable Number	Description	Payable Date	Due Date	Discount Amount	Payable Amount	
<u>41419</u>	ACCT # 7900 0440 8038 5499 POSTAGE	04/14/2019	05/13/2019	0.00	470.67	
Check				05/06/2019	3,000.00	
Payable Number	Description	Payable Date	Due Date	Discount Amount	Payable Amount	
<u>41719</u>	ACCT # 7900 0440 8038 5499	04/17/2019	05/13/2019	0.00	3,000.00	
Check				05/06/2019	1,208.16	
Payable Number	Description	Payable Date	Due Date	Discount Amount	Payable Amount	
<u>INV15699551</u>	ACCT # 7900044080109295 POSTAGE & SUPPLIES	04/02/2019	05/13/2019	0.00	1,208.16	

Vendor Number	Vendor Name					Total Vendor Amount
<u>MARPLU</u>	MARK'S PLUMBING PARTS					439.09
Payment Type	Payment Number			Payment Date	Payment Amount	
Check				05/06/2019	439.09	
Payable Number	Description	Payable Date	Due Date	Discount Amount	Payable Amount	
<u>INV001791570</u>	CUST # 278898 ACORN.5GPM FLO-CONTROL	04/01/2019	05/13/2019	0.00	381.79	
<u>INV001792564</u>	CUST # 278898 FLOW WASHER - .35 GPM	04/17/2019	05/13/2019	0.00	57.30	

Vendor Number	Vendor Name					Total Vendor Amount
<u>MARRAY</u>	MARTIN RAY MARTINEZ					30.00
Payment Type	Payment Number			Payment Date	Payment Amount	
Check				05/06/2019	30.00	
Payable Number	Description	Payable Date	Due Date	Discount Amount	Payable Amount	
<u>41119</u>	6 HOG TAILS	04/11/2019	05/13/2019	0.00	30.00	

Payment Register

APPKT03083 - 5/13/19 A/P RUN

Vendor Number	Vendor Name					Total Vendor Amount
<u>MICVAN</u>	MICKEY VAN DYKE					60.00
Payment Type	Payment Number			Payment Date	Payment Amount	
Check				05/06/2019	60.00	
Payable Number	Description	Payable Date	Due Date	Discount Amount	Payable Amount	
<u>41119</u>	12 HOG TAILS	04/11/2019	05/13/2019	0.00	60.00	
Vendor Number	Vendor Name					Total Vendor Amount
<u>NEOPUS</u>	NEOPOST USA INC					662.98
Payment Type	Payment Number			Payment Date	Payment Amount	
Check				05/06/2019	322.30	
Payable Number	Description	Payable Date	Due Date	Discount Amount	Payable Amount	
<u>N7675862</u>	CUST # 01054254 CCJC 4/11 - 5/10/19	04/09/2019	05/13/2019	0.00	322.30	
Check				05/06/2019	340.68	
Payable Number	Description	Payable Date	Due Date	Discount Amount	Payable Amount	
<u>N7682973</u>	CUST # 01054254 2/15 - 5/14/19 LEASE # N15021278	04/12/2019	05/13/2019	0.00	340.68	
Vendor Number	Vendor Name					Total Vendor Amount
<u>OBAFUN</u>	O'BANNON FUNERAL HOME					1,190.00
Payment Type	Payment Number			Payment Date	Payment Amount	
Check				05/06/2019	1,190.00	
Payable Number	Description	Payable Date	Due Date	Discount Amount	Payable Amount	
<u>41319</u>	ANDREW GOODWIN / DOD - 4/13/19	04/13/2019	05/13/2019	0.00	595.00	
<u>41419</u>	PATSY MCDONALD / DOD: 4/14/19	04/14/2019	05/13/2019	0.00	595.00	
Vendor Number	Vendor Name					Total Vendor Amount
<u>OMNBAS</u>	OMNIBASE SERVICES OF TEXAS, LP					2,850.00
Payment Type	Payment Number			Payment Date	Payment Amount	
Check				05/06/2019	2,850.00	
Payable Number	Description	Payable Date	Due Date	Discount Amount	Payable Amount	
<u>41619</u>	1ST QTR 2019 ACTIVITY REPORT	04/16/2019	05/13/2019	0.00	2,850.00	
Vendor Number	Vendor Name					Total Vendor Amount
<u>ONCALL</u>	ON CALL MOBILE VETERINARY SERVICES					178.00
Payment Type	Payment Number			Payment Date	Payment Amount	
Check				05/06/2019	178.00	
Payable Number	Description	Payable Date	Due Date	Discount Amount	Payable Amount	
<u>2019-03-28</u>	TREATMENT # 2019-03-28 CASE # 2019 03 0072 ETC	03/28/2019	05/13/2019	0.00	107.00	
<u>2019-04-08</u>	CASE # 2019 03 0103 DUN QH / GREY QH	04/08/2019	05/13/2019	0.00	71.00	
Vendor Number	Vendor Name					Total Vendor Amount
<u>O'REIL</u>	O'REILLY AUTOMOTIVE, INC.					1,190.96
Payment Type	Payment Number			Payment Date	Payment Amount	
Check				05/06/2019	1,190.96	
Payable Number	Description	Payable Date	Due Date	Discount Amount	Payable Amount	
<u>0642-258545</u>	ACCT # 188092 NATIONAL - O	03/16/2019	03/16/2019	0.00	-64.92	
<u>0642-260503</u>	CUST # 188092 TAIL LIGHT K	03/26/2019	05/13/2019	0.00	27.99	
<u>0642-260663</u>	CUST # 188092 REPAIR KIT	03/27/2019	05/13/2019	0.00	10.98	
<u>0642-260667</u>	CUST # 188092 AIR FILTER	03/27/2019	05/13/2019	0.00	16.96	
<u>0642-260865</u>	CUST # 188092 IDLER PULLEY	03/28/2019	05/13/2019	0.00	65.10	
<u>0642-260873</u>	CUST # 188092 IDLER PULLEY	03/28/2019	03/28/2019	0.00	-31.48	
<u>0642-261056</u>	CUST # 188092 ALTERNATOR	03/29/2019	05/13/2019	0.00	327.56	
<u>0642-261081</u>	CUST # 188092 HOSE 3/4"	03/29/2019	05/13/2019	0.00	59.99	
<u>0642-263064</u>	CUST # 188092 WIX - CABIN AIR FILT	04/08/2019	05/13/2019	0.00	25.42	
<u>0642-263450</u>	CUST # 188092 AC CONDENSER / SEAT COVER	04/10/2019	05/13/2019	0.00	144.78	
<u>0642-263469</u>	CUST # 188092 SEAT COVER	04/10/2019	05/13/2019	0.00	40.99	
<u>0642-263489</u>	CUST # 188092 AC CONDENSER / SEAT COVER / SEAT CO	04/10/2019	04/10/2019	0.00	-185.77	
<u>0642-263702</u>	CUST # 188092 SEAT	04/11/2019	05/13/2019	0.00	357.14	
<u>0642-263717</u>	CUST # 188092 1 GAL ANTI FREZ	04/11/2019	05/13/2019	0.00	10.99	
<u>0642-263836</u>	CUST # 188092 COOLANT HOSE	04/12/2019	05/13/2019	0.00	16.64	
<u>0642-265789</u>	CUST # 188092 LACQ THINNER	04/22/2019	05/13/2019	0.00	22.65	

Payment Register

APPKT03083 - 5/13/19 A/P RUN

Payment Number	Vendor Name	Payment Date	Due Date	Discount Amount	Payable Amount
<u>0642-265925</u>	CUST # 188092 BATTERY	04/23/2019	05/13/2019	0.00	356.74
<u>0642-266027</u>	CUST # 188092 36# PSA SHET	04/23/2019	05/13/2019	0.00	4.62
<u>0642-266413</u>	CUST # 188092 36# PSA SHET	04/26/2019	05/13/2019	0.00	28.58
<u>0642-267041</u>	CUST # 188092 CORE RETURN	04/29/2019	05/13/2019	0.00	-44.00

Vendor Number	Vendor Name	Payment Type	Payment Number	Payment Date	Payment Amount	Total Vendor Amount
<u>ORKIN</u>	ORKIN - AUSTIN COMMERCIAL	Check		05/06/2019	292.27	292.27
Payable Number	Description	Payable Date	Due Date	Discount Amount	Payable Amount	
<u>181829581</u>	ACCT # 29121597 PC STANDARD-MONTHLY MARCH 201	03/27/2019	05/13/2019	0.00	292.27	

Vendor Number	Vendor Name	Payment Type	Payment Number	Payment Date	Payment Amount	Total Vendor Amount
<u>OSSACA</u>	OSS ACADEMY	Check		05/06/2019	65.00	65.00
Payable Number	Description	Payable Date	Due Date	Discount Amount	Payable Amount	
<u>55592R</u>	JAMES BOHAC - PID # 293065 CRISIS COMMUNICATIONS	04/23/2019	05/13/2019	0.00	65.00	

Vendor Number	Vendor Name	Payment Type	Payment Number	Payment Date	Payment Amount	Total Vendor Amount
<u>PAUEVA</u>	PAUL MATTHEW EVANS	Check		05/06/2019	860.00	860.00
Payable Number	Description	Payable Date	Due Date	Discount Amount	Payable Amount	
<u>18-063</u>	CAUSE # 18-063 UARLI SOBAN	04/01/2019	05/13/2019	0.00	305.00	
<u>2017-148 1</u>	CAUSE # 2017-148 ISAISH ORONA	04/01/2019	05/13/2019	0.00	255.00	
<u>45896</u>	CAUSE # 45896 CESAR VASQUEZ	03/20/2019	05/13/2019	0.00	300.00	

Vendor Number	Vendor Name	Payment Type	Payment Number	Payment Date	Payment Amount	Total Vendor Amount
<u>PBELEC</u>	PB ELECTRONICS INC.	Check		05/06/2019	241.50	241.50
Payable Number	Description	Payable Date	Due Date	Discount Amount	Payable Amount	
<u>136587</u>	HR-12 SWITCH ASSEMBLY BOARD	04/05/2019	05/13/2019	0.00	241.50	

Vendor Number	Vendor Name	Payment Type	Payment Number	Payment Date	Payment Amount	Total Vendor Amount
<u>PETTRA</u>	PETROLEUM TRADERS CORPORATION	Check		05/06/2019	5,528.24	5,528.24
Payable Number	Description	Payable Date	Due Date	Discount Amount	Payable Amount	
<u>1388430</u>	ACCT # 9901644/1 ULTRA LOW SULFUR #2 DIESEL LOW E	04/10/2019	05/13/2019	0.00	5,528.24	

Vendor Number	Vendor Name	Payment Type	Payment Number	Payment Date	Payment Amount	Total Vendor Amount
<u>PFGTEM</u>	PFG-TEMPLE	Check		05/06/2019	9,011.04	9,011.04
Payable Number	Description	Payable Date	Due Date	Discount Amount	Payable Amount	
<u>9478736</u>	CUST # 435577 DRY GROCERY / FROZEN	04/01/2019	05/13/2019	0.00	967.14	
<u>9482712</u>	CUST # 435577 DRY GROCERY / FROZEN	04/04/2019	05/13/2019	0.00	1,126.27	
<u>9485838</u>	CUST # 435577 DRY GROCERY / FROZEN	04/08/2019	05/13/2019	0.00	940.13	
<u>9489844</u>	CUST # 435577 DRY GROCERY / FROZEN	04/11/2019	05/13/2019	0.00	1,563.39	
<u>9492890</u>	CUST # 435577 DRY GROCERY / FROZEN	04/15/2019	05/13/2019	0.00	1,025.98	
<u>9496905</u>	CUST # 435577 DRY GROCERY / FROZEN	04/18/2019	05/13/2019	0.00	1,329.57	
<u>95000185</u>	CUST # 435577 DRY GROCERY / FROZEN	04/22/2019	05/13/2019	0.00	1,290.00	
<u>9503895</u>	CUST # 435577 DRY GROCERY / FROZEN	04/25/2019	05/13/2019	0.00	768.56	

Vendor Number	Vendor Name	Payment Type	Payment Number	Payment Date	Payment Amount	Total Vendor Amount
<u>PRISOL</u>	PRINTING SOLUTIONS	Check		05/06/2019	302.12	302.12
Payable Number	Description	Payable Date	Due Date	Discount Amount	Payable Amount	
<u>21576</u>	DARLA LAW - BUSINESS CARDS	02/02/2019	05/13/2019	0.00	64.00	

Payment Register

APPKT03083 - 5/13/19 A/P RUN

<u>21778</u>	# 10 REG ENV RAYMOND DELEON JOP	04/04/2019	05/13/2019	0.00	136.50
<u>21779</u>	COPIES - COLOR COPIES D200 MANUALS	04/04/2019	05/13/2019	0.00	20.70
<u>21867</u>	STYLIST PENS	04/10/2019	05/13/2019	0.00	20.92
<u>21887</u>	BUSINESS CARDS - JUDGE DELEON	04/23/2019	05/13/2019	0.00	60.00

Vendor Number	Vendor Name				Total Vendor Amount
<u>QUICOR</u>	QUILL CORPORATION				144.95
Payment Type	Payment Number			Payment Date	Payment Amount
Check				05/06/2019	144.95
Payable Number	Description	Payable Date	Due Date	Discount Amount	Payable Amount
<u>6215624</u>	ACCT # C4881802 CUST PO 3220-3110REPL COPY PAPER	03/29/2019	05/13/2019	0.00	144.95

Vendor Number	Vendor Name				Total Vendor Amount
<u>RDOEQU</u>	RDO EQUIPMENT CO.				643,731.00
Payment Type	Payment Number			Payment Date	Payment Amount
Check				05/06/2019	643,731.00
Payable Number	Description	Payable Date	Due Date	Discount Amount	Payable Amount
<u>E31832</u>	ACCT # 7269004 MOTOR GRADERS	04/30/2019	05/13/2019	0.00	643,731.00

Vendor Number	Vendor Name				Total Vendor Amount
<u>IKONOF</u>	RICOH USA, INC.				922.24
Payment Type	Payment Number			Payment Date	Payment Amount
Check				05/06/2019	922.24
Payable Number	Description	Payable Date	Due Date	Discount Amount	Payable Amount
<u>101994217</u>	ACCT # 505575-1010175A16 3/29 - 4/28/19	04/10/2019	05/13/2019	0.00	922.24

Vendor Number	Vendor Name				Total Vendor Amount
<u>ROBHAE</u>	ROBERT A HAEDGE				2,440.00
Payment Type	Payment Number			Payment Date	Payment Amount
Check				05/06/2019	2,440.00
Payable Number	Description	Payable Date	Due Date	Discount Amount	Payable Amount
<u>14-084</u>	CAUSE # 14-084 JENNIFER MARIE SALINAS	04/24/2019	05/13/2019	0.00	690.00
<u>17-191</u>	CAUSE # 17-191 ANTHONY LAMAR RICHARDSON	04/11/2019	05/13/2019	0.00	395.00
<u>17-195</u>	CAUSE # 17-195 RAUSHANIQUE TERRELL SHANNON	04/11/2019	05/13/2019	0.00	775.00
<u>17-238</u>	CAUSE # 17-238 JOSHUA ISAAC SERRATO	04/11/2019	05/13/2019	0.00	580.00

Vendor Number	Vendor Name				Total Vendor Amount
<u>RUENIE</u>	RUEBEN NIEMANN				185.00
Payment Type	Payment Number			Payment Date	Payment Amount
Check				05/06/2019	185.00
Payable Number	Description	Payable Date	Due Date	Discount Amount	Payable Amount
<u>41119</u>	37 HOG TAILS	04/11/2019	05/13/2019	0.00	185.00

Vendor Number	Vendor Name				Total Vendor Amount
<u>SCHSON</u>	SCHMIDT & SONS, INC				3,538.68
Payment Type	Payment Number			Payment Date	Payment Amount
Check				05/06/2019	3,538.68
Payable Number	Description	Payable Date	Due Date	Discount Amount	Payable Amount
<u>0446050-IN</u>	CUST # 05-CALDCO FS SYNTHETIC BLEND 15W-40 CK4/SI	04/25/2019	05/13/2019	0.00	1,029.37
<u>0446051-IN</u>	CUST # 05-CALDCO PREMIUM TRACTOR FLUID BULK	04/25/2019	05/13/2019	0.00	1,544.09
<u>0446149-IN</u>	CUST # 05-CALDCO CHV DELO TORQFORCE SAE 30 1/55	04/29/2019	05/13/2019	0.00	995.50
<u>4460518-IN</u>	CUST # 05-CALDCO PREMIUM TRACTOR FLUID BULK	04/25/2019	05/13/2019	0.00	1,513.81
<u>446051A-CM</u>	CUST # 05-CALDCO PREMIUM TRACTOR FLUID BULK	04/25/2019	04/25/2019	0.00	-1,544.09

Vendor Number	Vendor Name				Total Vendor Amount
<u>SCHFIR</u>	SCHMIDT FIRE & SAFETY CO.				478.50
Payment Type	Payment Number			Payment Date	Payment Amount
Check				05/06/2019	478.50
Payable Number	Description	Payable Date	Due Date	Discount Amount	Payable Amount
<u>018757</u>	CONSTABLES PRCT #2	04/24/2019	05/13/2019	0.00	79.50
<u>018758</u>	FANNIN STREET ANNEX	04/24/2019	05/13/2019	0.00	72.00
<u>19054</u>	SCOTT ANNEX BLDG	04/26/2019	05/13/2019	0.00	87.00

Payment Register

APPKT03083 - 5/13/19 A/P RUN

Payment Number	Vendor Name	Payment Date	Due Date	Payment Amount	Total Vendor Amount
19055	ENVIROMENTAL	04/26/2019	05/13/2019	0.00	4.00
19056	JUVENILE DETENTION	04/26/2019	05/13/2019	0.00	12.00
19057	DRC	04/26/2019	05/13/2019	0.00	12.00
19058	MAINTENANCE	04/26/2019	05/13/2019	0.00	58.00
19059	405 E MARKET	04/26/2019	05/13/2019	0.00	8.00
19060	RED SHOW BARN	04/26/2019	05/13/2019	0.00	8.00
19061	OFFICE OF EMERGENCY MGMT	04/26/2019	05/13/2019	0.00	74.00
19062	PRCT # 1	04/26/2019	05/13/2019	0.00	4.00
19063	COURTHOUSE	04/26/2019	05/13/2019	0.00	52.00
19064	EXTENTION AGENT TRUCK	04/26/2019	05/13/2019	0.00	4.00
19065	PRCT # 3 OFFICE	04/26/2019	05/13/2019	0.00	4.00

Vendor Number	Vendor Name	Payment Type	Payment Number	Payment Date	Payment Amount	Total Vendor Amount	
SUSSCH	SCHOON LAW FIRM, PC	Check		05/06/2019	1,318.05	1,318.05	
		Payable Number	Description	Payable Date	Due Date	Discount Amount	Payable Amount
		12-060 / 13-195	CAUSE # 12-060 / 13-195 RICHARD RAMIREZ	04/24/2019	05/13/2019	0.00	300.55
		12-205	CAUSE # 12-205 JOSE TRINIDAD	04/04/2019	05/13/2019	0.00	300.50
		18-223 / 10-245	CAUSE # 18-223 / 10-245 CHRIS VELASQUEZ	04/24/2019	05/13/2019	0.00	546.50
		201901-0039	CAUSE # 201901-0039 JOYCE WHITE	04/05/2019	05/13/2019	0.00	170.50

Vendor Number	Vendor Name	Payment Type	Payment Number	Payment Date	Payment Amount	Total Vendor Amount	
REDAUT	SEAN MATTHEW MANN	Check		05/06/2019	296.65	296.65	
		Payable Number	Description	Payable Date	Due Date	Discount Amount	Payable Amount
		099391	ACCT # 2010 AIR CONDITIONING	04/10/2019	05/13/2019	0.00	129.99
		099504	ACCT # 2010 NAPAGOLD FUEL FILTER	04/15/2019	05/13/2019	0.00	16.55
		099717	ACCT # 2010 32 PREMIUM BUG WASH	04/24/2019	05/13/2019	0.00	47.88
		099755	ACCT # 2010 GAS CAP	04/26/2019	05/13/2019	0.00	6.24
		101019	CUST # 2010 DOOR HANDLE - INTERIOR	04/30/2019	05/13/2019	0.00	95.99

Vendor Number	Vendor Name	Payment Type	Payment Number	Payment Date	Payment Amount	Total Vendor Amount	
SECONE	SECURITY ONE, INC	Check		05/06/2019	25.00	25.00	
		Payable Number	Description	Payable Date	Due Date	Discount Amount	Payable Amount
		870765	CUST # 805335 ALARM MONITORING/MAY 2019	05/01/2019	05/13/2019	0.00	25.00

Vendor Number	Vendor Name	Payment Type	Payment Number	Payment Date	Payment Amount	Total Vendor Amount	
SHACON	SHANNA CONLEY	Check		05/06/2019	50.11	50.11	
		Payable Number	Description	Payable Date	Due Date	Discount Amount	Payable Amount
		42019	MILEAGE FOR TRAINING 4/8 - 11/19	04/17/2019	05/13/2019	0.00	50.11

Vendor Number	Vendor Name	Payment Type	Payment Number	Payment Date	Payment Amount	Total Vendor Amount	
SMISUP	SMITH SUPPLY CO.- LOCKHART	Check		05/06/2019	1,425.04	1,425.04	
		Payable Number	Description	Payable Date	Due Date	Discount Amount	Payable Amount
		805125	INSERT INT IMPACT T20 66220	04/01/2019	05/13/2019	0.00	17.25
		805148	CHAPIN POLY SPRAYER 3GL	04/01/2019	05/13/2019	0.00	23.95
		805169	PAD 16' X 8' X 2" CONCRETE	04/01/2019	05/13/2019	0.00	21.60
		805245	PROPANE FUEL CYLINDER 141 RED	04/02/2019	05/13/2019	0.00	13.90
		805382	STAKE NAIL 18 INCH WPS118	04/03/2019	05/13/2019	0.00	24.50
		805384	HEX NUT FULL 5/16	04/03/2019	05/13/2019	0.00	40.00
		805424	CEMENT - READY MIX 80#	04/03/2019	05/13/2019	0.00	39.80
		805674	ACRH 15" MTL, CLVRT D1 16GA	04/05/2019	05/13/2019	0.00	811.80
		805741	BLACK NIPPLE STD 3/4 X 48	04/05/2019	05/13/2019	0.00	38.85
		805926	GLOSS WINTER GRAY SPRAY	04/08/2019	05/13/2019	0.00	14.85

Payment Register

APPKT03083 - 5/13/19 A/P RUN

Item #	Description	04/11/2019	05/13/2019	0.00	58.26
806355	TORPEDO LEVEL STNLY 9"	04/12/2019	05/13/2019	0.00	32.00
806564	SQUARE TUBE 1-1/2" X 20' 140 .083	04/15/2019	05/13/2019	0.00	67.90
806734	T-POST 6'25 HVY STEEL SCLP	04/15/2019	05/13/2019	0.00	8.75
806804	SNAP LINK UNCP 5/16 UNCP 40106	04/17/2019	05/13/2019	0.00	60.40
807031	FLUOR ORANGE MARKING	04/17/2019	05/13/2019	0.00	27.90
807050	RATCHET WRENCH FLEXIBLE 1/2"	04/22/2019	05/13/2019	0.00	27.50
807540	MARKING PAINT RED-ORANGE	04/24/2019	05/13/2019	0.00	43.08
807839	WASHER FLAT 1/4 EG	04/26/2019	05/13/2019	0.00	10.95
807989	POLY LEAF RAKE LPIS	04/29/2019	05/13/2019	0.00	34.80
808233	FLAT BLACK SPRAY	05/01/2019	05/13/2019	0.00	7.00
808544	TEE HINGES 3" ZC CD				

Vendor Number Vendor Name Total Vendor Amount
SMILUL SMITH SUPPLY CO.-LULING 90.91

Payment Type	Payment Number	Payment Date	Payment Amount		
Check		05/06/2019	90.91		
Payable Number	Description	Payable Date	Due Date	Discount Amount	Payable Amount
<u>68703</u>	GELL CELL 12V 7AMP PS1270	04/15/2019	05/13/2019	0.00	33.90
<u>69066</u>	FLUOR ORANGE MARKING SPY	04/29/2019	05/13/2019	0.00	37.06
<u>69079</u>	MONSTER MAGGRIP 1Z30' MAG TIP	04/29/2019	05/13/2019	0.00	19.95

Vendor Number Vendor Name Total Vendor Amount
SOUHEA SOUTHERN HEALTH PARTNERS, INC. 45,481.32

Payment Type	Payment Number	Payment Date	Payment Amount		
Check		05/06/2019	45,481.32		
Payable Number	Description	Payable Date	Due Date	Discount Amount	Payable Amount
<u>BASE35050</u>	CUST ID: CAL-7388 PROVISION FOR HEALTH SERVICES	04/02/2019	05/13/2019	0.00	39,489.34
<u>OCP13634</u>	CUST ID: MARCH 2019 OCP COST POOL LIMITATION	03/31/2019	05/13/2019	0.00	5,991.98

Vendor Number Vendor Name Total Vendor Amount
SOUTIR SOUTHERN TIRE MART, LLC 1,190.00

Payment Type	Payment Number	Payment Date	Payment Amount		
Check		05/06/2019	1,190.00		
Payable Number	Description	Payable Date	Due Date	Discount Amount	Payable Amount
<u>4650008078</u>	CUST # 142726 SPOT REPAIR	04/22/2019	05/13/2019	0.00	225.00
<u>4650009733</u>	V-STL ULTRA TRACT G2 1	04/24/2019	05/13/2019	0.00	965.00

Vendor Number Vendor Name Total Vendor Amount
SOUFIL SOUTHWEST FILING & STORAGE 865.20

Payment Type	Payment Number	Payment Date	Payment Amount		
Check		05/06/2019	865.20		
Payable Number	Description	Payable Date	Due Date	Discount Amount	Payable Amount
<u>15464.1</u>	300 GOLDENROD CASE BINDERS	04/25/2019	05/13/2019	0.00	432.60
<u>15464.2</u>	300 RED CASE BINDERS	04/25/2019	05/13/2019	0.00	432.60

Vendor Number Vendor Name Total Vendor Amount
SPRINT SPRINT 37.99

Payment Type	Payment Number	Payment Date	Payment Amount		
Check		05/06/2019	37.99		
Payable Number	Description	Payable Date	Due Date	Discount Amount	Payable Amount
<u>122236591-121</u>	ACCT # 122236591 3/17 - 4/16/19	04/20/2019	05/13/2019	0.00	37.99

Vendor Number Vendor Name Total Vendor Amount
STEBEC STEPHEN BECK 105.00

Payment Type	Payment Number	Payment Date	Payment Amount		
Check		05/06/2019	105.00		
Payable Number	Description	Payable Date	Due Date	Discount Amount	Payable Amount
<u>41119</u>	21 TAILS	04/11/2019	05/13/2019	0.00	105.00

Payment Register

APPKT03083 - 5/13/19 A/P RUN

Vendor Number	Vendor Name					Total Vendor Amount
<u>SYSCO</u>	SYSCO CENTRAL TEXAS, INC					12,941.79
Payment Type	Payment Number			Payment Date	Payment Amount	
Check				05/06/2019	12,941.79	
Payable Number	Description	Payable Date	Due Date	Discount Amount	Payable Amount	
<u>313394424</u>	CUST# 043430 CHEMICAL & JANITORIAL	04/03/2019	05/13/2019	0.00	313.63	
<u>313394425</u>	CUST # 043430 DAIRY/MEATS/POULTRY/FROZEN ETC	04/03/2019	05/13/2019	0.00	1,937.00	
<u>313400955</u>	CUST # 043430 DAIRY/MEATS/POULTRY/FROZEN ETC	04/05/2019	05/13/2019	0.00	1,247.93	
<u>313414056</u>	CUST # 043430 DAIRY/MEATS/POULTRY/FROZEN/CAN &	04/10/2019	05/13/2019	0.00	1,182.73	
<u>313414057</u>	CUST # 043430 CHEMICAL / JANITORIAL	04/10/2019	05/13/2019	0.00	152.27	
<u>313420554</u>	CUST # 043430 DAIRY/MEATS/POULTRY/FROZEN/CAN &	04/12/2019	05/13/2019	0.00	1,446.47	
<u>313433280</u>	CUST # 043430 DAIRY/MEATS/FROZEN/CAN & DRY	04/17/2019	05/13/2019	0.00	1,910.28	
<u>313433281</u>	CUST # 043430 CHEMICAL & JANITORIAL	04/17/2019	05/13/2019	0.00	313.63	
<u>313439604</u>	CUST # 043430 DAIRY/MEATS/POULTRY/FROZEN/CAN	04/19/2019	05/13/2019	0.00	1,565.58	
<u>313452865</u>	CUST # 043430 DAIRY / FROZEN / CAN & DRY	04/24/2019	05/13/2019	0.00	1,143.60	
<u>313459501</u>	CUST # 043430 DAIRY / MEATS / POULTRY / FROZEN	04/26/2019	05/13/2019	0.00	1,728.67	

Vendor Number	Vendor Name					Total Vendor Amount
<u>T7ENTE</u>	T7 ENTERPRISES, LLC					296.00
Payment Type	Payment Number			Payment Date	Payment Amount	
Check				05/06/2019	296.00	
Payable Number	Description	Payable Date	Due Date	Discount Amount	Payable Amount	
<u>5573</u>	PASSENGER/LIGHT TRUCK	04/03/2019	05/13/2019	0.00	296.00	

Vendor Number	Vendor Name					Total Vendor Amount
<u>TABCAR</u>	TABITHA CARROLL					96.00
Payment Type	Payment Number			Payment Date	Payment Amount	
Check				05/06/2019	96.00	
Payable Number	Description	Payable Date	Due Date	Discount Amount	Payable Amount	
<u>41019</u>	GALVESTON TRAINING - 3/31 - 4/02/19	04/10/2019	05/13/2019	0.00	96.00	

Vendor Number	Vendor Name					Total Vendor Amount
<u>TAHSTE</u>	TAHLIA T. STEWART					1,323.00
Payment Type	Payment Number			Payment Date	Payment Amount	
Check				05/06/2019	1,323.00	
Payable Number	Description	Payable Date	Due Date	Discount Amount	Payable Amount	
<u>18-FL-110_5</u>	CAUSE # 18-FL-110 N.A.	04/25/2019	05/13/2019	0.00	434.00	
<u>19-FL-005_1</u>	CAUSE # 19-FL-005 V.M. & D.M.	03/14/2019	05/13/2019	0.00	448.00	
<u>19-FL-005_2</u>	CAUSE # 19-FL-005 V.M. / D.M.	04/25/2019	05/13/2019	0.00	441.00	

Vendor Number	Vendor Name					Total Vendor Amount
<u>TAYSEC</u>	TAYLOR SECURITY SYSTEMS, LLC					225.00
Payment Type	Payment Number			Payment Date	Payment Amount	
Check				05/06/2019	225.00	
Payable Number	Description	Payable Date	Due Date	Discount Amount	Payable Amount	
<u>77320</u>	ACCT # 60-03-7285F SERVICE CALL 4/1/19	04/19/2019	05/13/2019	0.00	225.00	

Vendor Number	Vendor Name					Total Vendor Amount
<u>TACDUE</u>	TEXAS ASSOCIATION OF COUNTIES					60.00
Payment Type	Payment Number			Payment Date	Payment Amount	
Check				05/06/2019	60.00	
Payable Number	Description	Payable Date	Due Date	Discount Amount	Payable Amount	
<u>249270</u>	ANITA DELEON - JPCA MEMBERSHIP DUES 2019	04/01/2019	05/13/2019	0.00	60.00	

Vendor Number	Vendor Name					Total Vendor Amount
<u>TACEDU</u>	TEXAS ASSOCIATION OF COUNTIES					275.00
Payment Type	Payment Number			Payment Date	Payment Amount	
Check				05/06/2019	275.00	
Payable Number	Description	Payable Date	Due Date	Discount Amount	Payable Amount	
<u>MEMBER ID: 216078</u>	TINA M. FREEMAN - 6/23 - 27/19 124TH ANNUAL CO & C	05/01/2019	05/13/2019	0.00	275.00	

Payment Register

APPKT03083 - 5/13/19 A/P RUN

Vendor Number	Vendor Name					Total Vendor Amount
COLJUD	TEXAS COLLEGE OF PROBATE JUDGES					375.00
Payment Type	Payment Number					Payment Date Payment Amount
Check						05/06/2019 375.00
Payable Number	Description	Payable Date	Due Date	Discount Amount	Payable Amount	
52109	TERESA RODRIGUEZ - 5/30-31/19	04/25/2019	05/13/2019	0.00	375.00	
Vendor Number	Vendor Name					Total Vendor Amount
TEXGAT	TEXAS GATE REPAIR					553.65
Payment Type	Payment Number					Payment Date Payment Amount
Check						05/06/2019 553.65
Payable Number	Description	Payable Date	Due Date	Discount Amount	Payable Amount	
3537	REMOVE AND REPLACE OLD CHAIN, INTALL & NEW	04/18/2019	05/13/2019	0.00	553.65	
Vendor Number	Vendor Name					Total Vendor Amount
SWTSU	TEXAS JUSTICE COURT TRAINING					100.00
Payment Type	Payment Number					Payment Date Payment Amount
Check						05/06/2019 100.00
Payable Number	Description	Payable Date	Due Date	Discount Amount	Payable Amount	
46169	JENNIFER WALKER - 8/19/19 FY_19 LEGISLATUVE UPDAT	03/20/2019	05/13/2019	0.00	100.00	
Vendor Number	Vendor Name					Total Vendor Amount
TEXNOT	TEXAS STATE NOTARY BUREAU					30.99
Payment Type	Payment Number					Payment Date Payment Amount
Check						05/06/2019 30.99
Payable Number	Description	Payable Date	Due Date	Discount Amount	Payable Amount	
131972105	FILE # 131972105 AMY TYNAN HORNE	04/30/2019	05/13/2019	0.00	30.99	
Vendor Number	Vendor Name					Total Vendor Amount
TEXJUS	TEXAS STATE UNIVERSITY					100.00
Payment Type	Payment Number					Payment Date Payment Amount
Check						05/06/2019 100.00
Payable Number	Description	Payable Date	Due Date	Discount Amount	Payable Amount	
46169	JENNIFER WALKER - 8/19/19 FY_19 LEGISLATIVE UPDATE	03/20/2019	05/13/2019	0.00	100.00	
Vendor Number	Vendor Name					Total Vendor Amount
JAMCAS	THE CASEY LAW FIRM					1,970.00
Payment Type	Payment Number					Payment Date Payment Amount
Check						05/06/2019 1,970.00
Payable Number	Description	Payable Date	Due Date	Discount Amount	Payable Amount	
17-115	CAUSE # 17-115 JOSHUA S. HILL	04/23/2019	05/13/2019	0.00	825.00	
17-172	CAUSE # 17-172 ANTONIO CORTEZ	04/24/2019	05/13/2019	0.00	690.00	
18-205	CAUSE # 18-205 ABNER GREENE	04/23/2019	05/13/2019	0.00	455.00	
Vendor Number	Vendor Name					Total Vendor Amount
RICHC	THE LAW OFFICE OF TREY HICKS, PLLC					1,000.00
Payment Type	Payment Number					Payment Date Payment Amount
Check						05/06/2019 1,000.00
Payable Number	Description	Payable Date	Due Date	Discount Amount	Payable Amount	
45994	CAUSE # 45994 BRIAN CASTRO	03/21/2019	05/13/2019	0.00	500.00	
47,224 / 47,225	CAUSE # 47,224 & 47,225 QUINTON MACKEY SMITH	03/18/2019	05/13/2019	0.00	500.00	
Vendor Number	Vendor Name					Total Vendor Amount
CARWAR	THE LAW OFFICES OF CARRIE WARD PLLC					1,428.00
Payment Type	Payment Number					Payment Date Payment Amount
Check						05/06/2019 1,428.00
Payable Number	Description	Payable Date	Due Date	Discount Amount	Payable Amount	
17-FL-287_9	CAUSE # 17-FL-287 Z.M.R.	04/25/2019	05/13/2019	0.00	98.00	
18-FL-118_10	CAUSE # 18-FL-118 B.B.S.B.	04/25/2019	05/13/2019	0.00	280.00	
18-FL-312_2	CAUSE # 18-FL-312 I/G.	04/25/2019	05/13/2019	0.00	70.00	
18-FL-317_1	CAUSE # 18-FL-317 VASQUEZ	04/25/2019	05/13/2019	0.00	140.00	
18-FL-448_4	CAUSE # 18-FL-448 PG & JG	04/25/2019	05/13/2019	0.00	378.00	

Payment Register

APPKT03083 - 5/13/19 A/P RUN

<u>19-FL-047 1</u>	CAUSE # 1-FL-047 G/M	04/25/2019	05/13/2019	0.00	259.00
<u>19-FL-103</u>	CAUSE # 19-FL-103 O.	04/25/2019	05/13/2019	0.00	203.00

Vendor Number <u>JASTRU</u>	Vendor Name THE LAW OFFICES OF JASON TRUMPLER				Total Vendor Amount 455.00
Payment Type Check	Payment Number	Payment Date	Payment Amount		
		05/06/2019	455.00		
Payable Number <u>17-189</u>	Description CAUSE # 17-189 CHRISTOPHER WIRE	Payable Date 04/08/2019	Due Date 05/13/2019	Discount Amount 0.00	Payable Amount 455.00

Vendor Number <u>TRARIS</u>	Vendor Name TRANSUNION RISK AND ALTERNATIVE DATA SOLUTION				Total Vendor Amount 50.00
Payment Type Check	Payment Number	Payment Date	Payment Amount		
		05/06/2019	50.00		
Payable Number <u>234599-201904-1</u>	Description ACCT # 234599 APRIL 2019	Payable Date 05/01/2019	Due Date 05/13/2019	Discount Amount 0.00	Payable Amount 50.00

Vendor Number <u>TRACLE</u>	Vendor Name TRAVIS COUNTY CLERK				Total Vendor Amount 458.00
Payment Type Check	Payment Number	Payment Date	Payment Amount		
		05/06/2019	458.00		
Payable Number <u>19-000810</u>	Description CAUSE # C-1-MH-19-000810 HENSON LAWRENCE	Payable Date 04/19/2019	Due Date 05/13/2019	Discount Amount 0.00	Payable Amount 458.00

Vendor Number <u>TEXTOL</u>	Vendor Name TXTAG				Total Vendor Amount 14.63
Payment Type Check	Payment Number	Payment Date	Payment Amount		
		05/06/2019	14.63		
Payable Number <u>195918322242</u>	Description ACCT # 442026564 PLATE # TX-1110344	Payable Date 04/04/2019	Due Date 05/13/2019	Discount Amount 0.00	Payable Amount 14.63

Vendor Number <u>TYLTEC</u>	Vendor Name TYLER TECHNOLOGIES, INC.				Total Vendor Amount 275.00
Payment Type Check	Payment Number	Payment Date	Payment Amount		
		05/06/2019	275.00		
Payable Number <u>025-254049</u>	Description CUST # 47804 PURCHASING REQ TO CHECK PART I	Payable Date 03/19/2019	Due Date 05/13/2019	Discount Amount 0.00	Payable Amount 137.50
Payable Number <u>025-254054</u>	Description CUST # 47804 PURCHASING REQ TO CHECK PART II	Payable Date 03/19/2019	Due Date 05/13/2019	Discount Amount 0.00	Payable Amount 137.50

Vendor Number <u>UNIFIR</u>	Vendor Name UNIFIRST CORPORATION				Total Vendor Amount 1,140.74
Payment Type Check	Payment Number	Payment Date	Payment Amount		
		05/06/2019	1,140.74		
Payable Number <u>822 2181552</u>	Description CUST # 222727 RTE # G6580 PRCT # 3	Payable Date 03/29/2019	Due Date 05/13/2019	Discount Amount 0.00	Payable Amount 45.34
Payable Number <u>822 2183516</u>	Description CUST # 222727 RTE # F6140 SHERIFF'S	Payable Date 04/05/2019	Due Date 05/13/2019	Discount Amount 0.00	Payable Amount 65.01
Payable Number <u>822 2183785</u>	Description CUST # 222727 RTE # G6580 PRCT # 3	Payable Date 04/05/2019	Due Date 05/13/2019	Discount Amount 0.00	Payable Amount 42.73
Payable Number <u>822 2185257</u>	Description CUST # 222727 RTE # F6140 SHERIFF'S	Payable Date 04/12/2019	Due Date 05/13/2019	Discount Amount 0.00	Payable Amount 65.01
Payable Number <u>822 2185821</u>	Description CUST # 222727 RTE # F6110 COUNTY COURT HOUSE	Payable Date 04/12/2019	Due Date 05/13/2019	Discount Amount 0.00	Payable Amount 238.97
Payable Number <u>822 2186152</u>	Description CUST # 222727 RTE # F2900 PRCT # 2	Payable Date 04/15/2019	Due Date 05/13/2019	Discount Amount 0.00	Payable Amount 46.91
Payable Number <u>822 2188060</u>	Description CUST # 222727 RTE # F6110 COURT HOUSE	Payable Date 04/19/2019	Due Date 05/13/2019	Discount Amount 0.00	Payable Amount 238.97
Payable Number <u>822 2188416</u>	Description CUST # 222727 RTE # F2900 PRCT # 2	Payable Date 04/22/2019	Due Date 05/13/2019	Discount Amount 0.00	Payable Amount 46.91
Payable Number <u>822 2190217</u>	Description CUST # 222727 RTE # F6140 SHERIFF'S	Payable Date 04/26/2019	Due Date 05/13/2019	Discount Amount 0.00	Payable Amount 65.01
Payable Number <u>822 2190277</u>	Description CUST # 222727 RTE # F6110 COURTHOUSE	Payable Date 04/26/2019	Due Date 05/13/2019	Discount Amount 0.00	Payable Amount 238.97
Payable Number <u>822 2190619</u>	Description CUST # 222727 RTE # 2 PRCT # 2	Payable Date 04/29/2019	Due Date 05/13/2019	Discount Amount 0.00	Payable Amount 46.91

Payment Register

Vendor Number	Vendor Name						Total Vendor Amount
<u>UNRENT</u>	UNITED RENTALS (NORTH AMERICA), INC.						527.70
Payment Type	Payment Number					Payment Date	Payment Amount
Check						05/06/2019	527.70
Payable Number	Description	Payable Date	Due Date	Discount Amount	Payable Amount		
<u>166921709-002</u>	CUST # 1331322 SCISSOR LIFT 19' ELECTRIC	04/20/2019	05/13/2019	0.00	527.70		
<u>VALRAM</u>	VALENTINE RAMIREZ						915.00
Payment Type	Payment Number					Payment Date	Payment Amount
Check						05/06/2019	915.00
Payable Number	Description	Payable Date	Due Date	Discount Amount	Payable Amount		
<u>41119</u>	183 TAILS	04/11/2019	05/13/2019	0.00	915.00		
<u>VICBRO</u>	VICTOREA D. BROWN						2,449.32
Payment Type	Payment Number					Payment Date	Payment Amount
Check						05/06/2019	2,449.32
Payable Number	Description	Payable Date	Due Date	Discount Amount	Payable Amount		
<u>18-297</u>	CAUSE # 18-297 JUAN HERRERA	04/17/2019	05/13/2019	0.00	757.41		
<u>44477</u>	CAUSE # 44477 RYAN ODELL PEARSON	03/20/2019	05/13/2019	0.00	305.00		
<u>45854</u>	CAUSE # 45854 LUTHER PERIN YAMTHE	03/20/2019	05/13/2019	0.00	350.00		
<u>47096</u>	CAUSE # 47096 ARACELI ARRIETA	03/20/2019	05/13/2019	0.00	1,036.91		
<u>VINCON</u>	VINYL CONNECTION						492.00
Payment Type	Payment Number					Payment Date	Payment Amount
Check						05/06/2019	492.00
Payable Number	Description	Payable Date	Due Date	Discount Amount	Payable Amount		
<u>931</u>	15" X 50 YDS ENGINEER GRADE WHITE UN-PUNCHED	04/12/2019	05/13/2019	0.00	492.00		
<u>WALDEA</u>	WALTER S. DEAN, SR.						2,015.00
Payment Type	Payment Number					Payment Date	Payment Amount
Check						05/06/2019	2,015.00
Payable Number	Description	Payable Date	Due Date	Discount Amount	Payable Amount		
<u>18-127 1</u>	CAUSE # 18-127 JENNIFER LIN ROJAS	11/19/2018	05/13/2019	0.00	505.00		
<u>18-307</u>	CAUSE # 18-307 OTABIANO JAIMES III	04/09/2019	05/13/2019	0.00	755.00		
<u>2018-219</u>	CAUSE # 2018-219 OTABINO JAIMES III	04/09/2019	05/13/2019	0.00	755.00		
<u>WILKOC</u>	WILLIAM C. KOCTAR						75.00
Payment Type	Payment Number					Payment Date	Payment Amount
Check						05/06/2019	75.00
Payable Number	Description	Payable Date	Due Date	Discount Amount	Payable Amount		
<u>41119</u>	15 HOG TAILS	04/11/2019	05/13/2019	0.00	75.00		
<u>WILRIG</u>	WILSON RIGGIN						5.89
Payment Type	Payment Number					Payment Date	Payment Amount
Check						05/06/2019	5.89
Payable Number	Description	Payable Date	Due Date	Discount Amount	Payable Amount		
<u>104249</u>	1 QT PAINT THINNER	03/28/2019	05/13/2019	0.00	5.89		
<u>XERBUS</u>	XEROX BUSINESS SOLUTIONS SOUTHWEST						184.75
Payment Type	Payment Number					Payment Date	Payment Amount
Check						05/06/2019	184.75
Payable Number	Description	Payable Date	Due Date	Discount Amount	Payable Amount		
<u>IN1991875</u>	CONTRACT # CN31402-01 OVERAGE CHARGE 12/30/18-3	04/02/2019	05/13/2019	0.00	184.75		

Payment Register

APPKT03083 - 5/13/19 A/P RUN

Vendor Number	Vendor Name			Total Vendor Amount	
XERCOR	XEROX CORPORATION			4,222.11	
Payment Type	Payment Number	Payment Date	Payment Amount		
Check		05/06/2019	4,051.11		
Payable Number	Description	Payable Date	Due Date	Discount Amount	Payable Amount
<u>1578650</u>	CONTRACT # 010-0063777-001 3/30-4/29	04/10/2019	05/13/2019	0.00	4,051.11
Check		05/06/2019	171.00		
Payable Number	Description	Payable Date	Due Date	Discount Amount	Payable Amount
<u>1578897</u>	CUST # 76391 CONTRACT # 010-0076391-001 3/30-4/29	04/10/2019	05/13/2019	0.00	171.00
Vendor Number	Vendor Name			Total Vendor Amount	
ZACMAN	ZACHARY RICK MANWILL			2,884.00	

Payment Type	Payment Number	Payment Date	Payment Amount		
Check		05/06/2019	2,884.00		
Payable Number	Description	Payable Date	Due Date	Discount Amount	Payable Amount
<u>18-FL-045 4</u>	CAUSE # 18-FL-045 GLASSCOCK	04/25/2019	05/13/2019	0.00	392.00
<u>18-FL-185 2</u>	CAUSE # 18-FL-185 GUTIERREZ	04/25/2019	05/13/2019	0.00	56.00
<u>18-FL-281 2</u>	CAUSE # 18-FL-281 Z.M.MF	04/25/2019	05/13/2019	0.00	126.00
<u>18-FL-288 1</u>	CAUSE # 18-FL-288 C.C.C-F	04/25/2019	05/13/2019	0.00	119.00
<u>18-FL-317 3</u>	CAUSE # 18-FL-317 K.V.	04/25/2019	05/13/2019	0.00	826.00
<u>18-FL-330 2</u>	CAUSE # 18-FL-330 T.G.J. / K.G.	04/25/2019	05/13/2019	0.00	35.00
<u>18-FL-474 1</u>	CAUSE # 18-FL-474 I.J.	04/25/2019	05/13/2019	0.00	210.00
<u>19-FL-005</u>	CAUSE # 19-FL-005 D & V. M.	04/25/2019	05/13/2019	0.00	238.00
<u>19-FL-027</u>	CAUSE # 19-FL-027 G.H.G. / A.J.G.	04/25/2019	05/13/2019	0.00	336.00
<u>19-FL-047</u>	CAUSE # 19-FL-047 J.G. / M.M	04/25/2019	05/13/2019	0.00	161.00
<u>19-FL-104</u>	CAUSE # 19-FL-104 D.S.	04/25/2019	05/13/2019	0.00	385.00

Payment Summary

Bank Code	Type	Payable Count	Payment Count	Discount	Payment
AP BNK	Check	489	168	0.00	1,178,971.37
Packet Totals:		489	168	0.00	1,178,971.37

Cash Fund Summary

Fund	Name	Amount
999	POOLED CASH	-1,178,971.37
Packet Totals:		<u>-1,178,971.37</u>

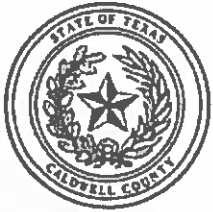

Expense Approval Register

Packet: APPKT03083 - 5/13/19 A/P RUN

Vendor Name	Payable Number	Description (Item)	Account Name	Account Number	Amount
Fund: 001 - GENERAL FUND					
LEON TRANSLATIONS	19267	CAUSE # 13-FL-313 SPANISH	TRIAL EXPENSE	001-3230-4170	160.00
4 SQUARE COMMUNICATIO	3769	TESTED LT. LARIVEE'S COMP	REPAIRS & MAINTENANCE	001-4310-4510	295.00
WALTER S. DEAN, SR.	18-127 1	CAUSE # 18-127 JENNIFER LI	ADULT - ATTY LITIGATION EX	001-3230-4080	5.00
WALTER S. DEAN, SR.	18-127 1	CAUSE # 18-127 JENNIFER LI	ADULT - INDIGENT ATTORNE	001-3230-4160	500.00
DEWITT POTH & SON	555374 - 0	CUST # 12430 PLANNER, MO	OFFICE SUPPLIES	001-3220-3110	87.16
4 SQUARE COMMUNICATIO	3768	ADMIN 2 NOT WORKING - PL	REPAIRS & MAINTENANCE	001-4310-4510	1,020.00
DEWITT POTH & SON	558499 - 0	CUST # 12430 ENVELOPE, CL	OFFICE SUPPLIES	001-3220-3110	39.24
PRINTING SOLUTIONS	21576	DARLA LAW - BUSINESS CAR	OFFICE SUPPLIES	001-2140-3110	64.00
BUILDING IMAGE GROUP, IN	22672	PROJECT # 22672 JUSTICE CE	JUDICIAL CENTER-LOCKHART	001-6520-3550	150.00
CENTRAL TEXAS MEDICAL CE	106135009	MADYSON ALLEN / PAT # 10	PROFESSIONAL SERVICES	001-4300-4110	483.00
TAHLIA T. STEWART	19-FL-005 1	CAUSE # 19-FL-005 V.M. & D	ADULT - INDIGENT ATTORNE	001-3230-4160	448.00
GT DISTRIBUTORS, INC.	INVO70160	CUST # 000297 FLEX CUFFS	OPERATING SUPPLIES	001-4310-3130	122.10
DEALERS ELECTRIC	1858639-01	CUST # 134031 IOTA I-420-E	JUDICIAL CENTER-LOCKHART	001-6520-3550	984.00
THE LAW OFFICE OF TREY HI	47,224 / 47,225	CAUSE # 47,224 & 47,225 Q	ADULT - INDIGENT ATTORNE	001-3240-4160	500.00
TYLER TECHNOLOGIES, INC.	025-254049	CUST # 47804 PURCHASING	TRAINING	001-6590-4810	137.50
TYLER TECHNOLOGIES, INC.	025-254054	CUST # 47804 PURCHASING	TRAINING	001-6590-4810	137.50
DEALERS ELECTRIC	1859310-00	CUST # 134031 TRANSPORA	JUDICIAL CENTER-LOCKHART	001-6520-3550	107.06
4 SQUARE COMMUNICATIO	3770	RECORDING SLOW ON COM	REPAIRS & MAINTENANCE	001-4310-4510	115.00
VICTOREA D. BROWN	44477	CAUSE # 44477 RYAN ODELL	ADULT - ATTY LITIGATION EX	001-3240-4080	5.00
VICTOREA D. BROWN	44477	CAUSE # 44477 RYAN ODELL	ADULT - INDIGENT ATTORNE	001-3240-4160	300.00
COLIN WISE	45698	CAUSE # 45698 EZEKIAL LEE	ADULT - INDIGENT ATTORNE	001-3240-4160	250.00
DAVID MENDOZA	45710	CAUSE # 45710 BRYAN BUSTI	ADULT - INDIGENT ATTORNE	001-3240-4160	450.00
VICTOREA D. BROWN	45854	CAUSE # 45854 LUTHER PERI	ADULT - INDIGENT ATTORNE	001-3240-4160	350.00
PAUL MATTHEW EVANS	45896	CAUSE # 45896 CESAR VASQ	ADULT - INDIGENT ATTORNE	001-3240-4160	300.00
DAN MCCORMACK	46,128	CAUSE # 46,128 JEYLAN ELLI	ADULT - INDIGENT ATTORNE	001-3240-4160	400.00
TEXAS JUSTICE COURT TRAIN	46169	JENNIFER WALKER - 8/19/19	TRAINING	001-3252-4810	100.00
TEXAS STATE UNIVERSITY	46169	JENNIFER WALKER - 8/19/19	TRAINING	001-3252-4810	100.00
VICTOREA D. BROWN	47096	CAUSE # 47096 ARACELI ARR	ADULT - ATTY LITIGATION EX	001-3240-4080	36.91
VICTOREA D. BROWN	47096	CAUSE # 47096 ARACELI ARR	ADULT - INDIGENT ATTORNE	001-3240-4160	1,000.00
THE LAW OFFICE OF TREY HI	45994	CAUSE # 45994 BRIAN CASTR	ADULT - INDIGENT ATTORNE	001-3240-4160	500.00
DEL PRADO-DIETZ, PLLC	46641	CAUSE # 46641 ALEXIS MCGI	ADULT - INDIGENT ATTORNE	001-3240-4160	1,500.00
BOVIK & MEREDITH P.C.	46974	CAUSE # 46974 WENDY HUR	ADULT - INDIGENT ATTORNE	001-3240-4160	300.00
DAN MCCORMACK	47,002	CAUSE # 47,002 LAMORA LO	ADULT - INDIGENT ATTORNE	001-3240-4160	650.00
DAN MCCORMACK	47,116	CAUSE # 47,116 JAMES CHA	ADULT - INDIGENT ATTORNE	001-3240-4160	800.00
BOVIK & MEREDITH P.C.	47260	CAUSE # 47260 AMY RODRI	ADULT - INDIGENT ATTORNE	001-3240-4160	300.00
BOVIK & MEREDITH P.C.	47407	CAUSE # 47407 OMAR MEDR	ADULT - ATTY LITIGATION EX	001-3240-4080	5.00
BOVIK & MEREDITH P.C.	47407	CAUSE # 47407 OMAR MEDR	ADULT - INDIGENT ATTORNE	001-3240-4160	350.00
ALAMO AREA COUNCIL OF G	04057	SEAN QUINN - INVESTIGATIO	TRAINING	001-4300-4810	50.00
GRUMBLES ELECTRIC CO.	18-1238	TROUBLESHOOT BURNT WA	REPAIRS & MAINTENANCE	001-4310-4510	560.00
LOCKHART HARDWARE	27935 /1	CUST # 11239 STOP & WAST	UNIT ROAD MAINTENANCE	001-6520-3630	25.79
LOCKHART HARDWARE	27939 /1	CUST # 11239 HURRICANE T	UNIT ROAD MAINTENANCE	001-6520-3630	28.88
LOCKHART HARDWARE	27946 /1	CUST # 11239 3/8 CDX PINE	UNIT ROAD MAINTENANCE	001-6520-3630	13.99
DEWITT POTH & SON	567411-0	CUST # 12430 FOLDER, FILE,	OFFICE SUPPLIES	001-3253-3110	49.70
ORKIN - AUSTIN COMMERC	181829581	ACCT # 29121597 PC STAND	PROFESSIONAL SERVICES	001-4310-4110	292.27
LOCKHART HARDWARE	27963 /1	CUST # 11239 RECIP SAW BL	BUILDING MAINTENANCE-LO	001-6520-3600	11.99
LOCKHART HARDWARE	27969 /1	CUST # 11239 PVC PIPE SCH	UNIT ROAD MAINTENANCE	001-6520-3630	49.02
LOCKHART HARDWARE	27970 /1	CUST # 11239 SCREWS, NUT	BUILDING MAINTENANCE-LO	001-6520-3600	24.66
CINTAS CORPORATION #86	4018975653	SOLD TO # 13228013 PAYER	UNIFORMS	001-6520-3140	81.02
CHARTER COMMUNICATION	0000426032819	ACCT # 8260 16 300 000042	Telephone	001-6510-4420	4,387.99
CHARTER COMMUNICATION	0000426032819	ACCT # 8260 16 300 000042	FAX & INTERNET	001-6510-4425	7,019.69
WILSON RIGGIN	104249	1 QT PAINT THINNER	JUDICIAL CENTER-LOCKHART	001-6520-3550	5.89
ON CALL MOBILE VETERINA	2019-03-28	TREATMENT # 2019-03-28 C	PROFESSIONAL SERVICES	001-4300-4110	107.00
LOCKHART HARDWARE	27981 /1	CUST # 11239 4X5 SCH40PV	UNIT ROAD MAINTENANCE	001-6520-3630	40.57

Expense Approval Register

Packet: APPKT03083 - 5/13/19 A/P RUN

Vendor Name	Payable Number	Description (Item)	Account Name	Account Number	Amount
LOCKHART HARDWARE	27983 /1	CUST # 11239 ELBOW 90L P	UNIT ROAD MAINTENANCE	001-6520-3630	56.89
LOCKHART HARDWARE	27987 /1	CUST # 11239 ADAPTR 1/2M	UNIT ROAD MAINTENANCE	001-6520-3630	8.57
GRAINGER	9129229622	ACCT # 841505548 FLUORES	REPAIRS & MAINTENANCE	001-4310-4510	111.30
GRAINGER	9129770054	ACCT # 841505548 INCAND	REPAIRS & MAINTENANCE	001-4310-4510	146.70
JOHN DEERE FINANCIAL	1903-009852	ACCT # 1-99 ROOFING - 26A	UNIT ROAD MAINTENANCE	001-6520-3630	16.40
QUILL CORPORATION	6215624	CUST # C4881802 CUST PO 3	OFFICE SUPPLIES	001-3220-3110	144.95
UNIFIRST CORPORATION	822 2181552	CUST # 222727 RTE # G6580	JP3 SIMON BUILDING-MAXW	001-6520-3500	45.34
GRAINGER	9131634819	ACCT # 841505548 SMOKE	REPAIRS & MAINTENANCE	001-4310-4510	34.59
ATCO INTERNATIONAL	10527049	CUST ID: 126786 ALL PRO	REPAIRS & MAINTENANCE	001-4310-4510	307.00
FERRIS JOSEPH PRODUCE, IN	108077	ICEBERG 24 CT	FOOD SUPPLIES	001-4310-3100	96.00
LIVENGOOD FEED STORE	LOINV000184020	CUST # 1C250	OPERATING SUPPLIES	001-4300-3130	161.97
LEGENDS TRI-COUNTY FUNE	2019/050	HUNTER COKE DOT: 3/26/1	AUTOPSY	001-6510-4123	300.00
BOWMAN CONSULTING GR	269907	PROJECT # 070004-14-005 C	Professional Services	001-6600-4110	300.00
BOWMAN CONSULTING GR	269908	PROJECT # 070004-68-001 H	Professional Services	001-6600-4110	450.00
BOWMAN CONSULTING GR	269911	PROJECT # 070004-77-001 F	Professional Services	001-6600-4110	500.00
BOWMAN CONSULTING GR	269912	PROJECT # 070004-78-001 I	Professional Services	001-6600-4110	300.00
BOWMAN CONSULTING GR	269913	PROJECT # 070004-79-001 S	Professional Services	001-6600-4110	300.00
SOUTHERN HEALTH PARTNE	OCP13634	CUST ID: MARCH 2019 OCP	PROFESSIONAL SERVICES	001-4310-4110	5,991.98
DEALERS ELECTRIC	1858263-01	CUST # 134031 IOTA I-32 TB	JUDICIAL CENTER-LOCKHART	001-6520-3550	643.69
FERRIS JOSEPH PRODUCE, IN	108082	ICEBERG 24 CT	FOOD SUPPLIES	001-4310-3100	91.00
PAUL MATTHEW EVANS	18-063	CAUSE # 18-063 UARLI SOB	ADULT - ATTY LITIGATION EX	001-3230-4080	5.00
PAUL MATTHEW EVANS	18-063	CAUSE # 18-063 UARLI SOB	ADULT - INDIGENT ATTORNE	001-3230-4160	300.00
PAUL MATTHEW EVANS	2017-148 1	CAUSE # 2017-148 ISAISH O	ADULT - ATTY LITIGATION EX	001-3230-4080	5.00
PAUL MATTHEW EVANS	2017-148 1	CAUSE # 2017-148 ISAISH O	ADULT - INDIGENT ATTORNE	001-3230-4160	250.00
TEXAS ASSOCIATION OF COU	249270	ANITA DELEON - JPCA MEMB	TRAINING	001-3253-4810	60.00
LOCKHART HARDWARE	28030 /1	CUST # 11239 POLYSHADE,	CALDWELL CO. COURTHOUS	001-6520-5120	14.58
LOCKHART HARDWARE	28040 /1	CUST # 11239 JIG BLD 3-5/8	BUILDING MAINTENANCE-LO	001-6520-3600	44.91
APPLIED CONCEPTS, INC.	345475	2 X COUNTING UNIT, 1.5 PCB	RENTALS	001-4325-4610	287.50
SMITH SUPPLY CO.- LOCKHA	805125	INSERT INT IMPACT T20 662	CALDWELL CO. COURTHOUS	001-6520-5120	17.25
SMITH SUPPLY CO.- LOCKHA	805169	PAD 16' X 8' X 2" CONCRETE	UNIT ROAD MAINTENANCE	001-6520-3630	21.60
PFG-TEMPLE	9478736	CUST # 435577 DRY GROCER	FOOD SUPPLIES	001-4310-3100	989.12
PFG-TEMPLE	9478736	CUST # 435577 DRY GROCER	FOOD SUPPLIES	001-4310-3100	-21.98
MARK'S PLUMBING PARTS	INV001791570	CUST # 278898 ACORN.5GP	REPAIRS & MAINTENANCE	001-4310-4510	381.79
RICOH USA, INC.	101994217	ACCT # 505575-1010175A16	RENTALS	001-6510-4610	922.24
FERRIS JOSEPH PRODUCE, IN	108207	POTATOES 5/10 LB BAGGED	FOOD SUPPLIES	001-4310-3100	100.50
XEROX CORPORATION	1578650	CONTRACT # 010-0063777-0	RENTALS	001-6510-4610	3,995.00
XEROX CORPORATION	1578650	CONTRACT # 010-0063777-0	RENTALS	001-6510-4610	56.11
XEROX CORPORATION	1578897	CUST # 76391 CONTRACT #	RENTALS	001-6510-4610	171.00
AIR COMMUNICATIONS, CO.	16855	CARRIER - 3.0" OD TELESCOP	OPERATING SUPPLIES	001-4310-3130	161.22
PRINTING SOLUTIONS	21867	STYLIST PENS	OFFICE SUPPLIES	001-6570-3110	20.92
SYSCO CENTRAL TEXAS, INC	313414056	CUST # 043430 DAIRY/MEA	FOOD SUPPLIES	001-4310-3100	1,146.69
SYSCO CENTRAL TEXAS, INC	313414056	CUST # 043430 DAIRY/MEA	OPERATING SUPPLIES	001-4310-3130	36.04
SYSCO CENTRAL TEXAS, INC	313414057	CUST # 043430 CHEMICAL /	OPERATING SUPPLIES	001-4310-3130	152.27
CINTAS CORPORATION #86	4019800797	SOLD TO # 13228013 PAYER	UNIFORMS	001-6520-3140	81.02
TABITHA CARROLL	41019	GALVESTON TRAINING - 3/3	TRAINING	001-4310-4810	96.00
DEWITT POTHS & SON	568792-0	CUST # 12430 SPOTPAPER	OFFICE SUPPLIES	001-3200-3110	316.39
DEWITT POTHS & SON	568893-0	CUST # 12430 BOX, SECURIT	OFFICE SUPPLIES	001-8700-3110	16.13
M.B. HAMMO ENTERPRISES,	6596	TOILET PAPER REGULAR / RO	OPERATING SUPPLIES	001-4310-3130	773.21
M.B. HAMMO ENTERPRISES,	6600	36" BLACK TAMPICO PUSH B	OPERATING SUPPLIES	001-4310-3130	104.70
GRAINGER	9142732784	ACCT # 841505548 KNOB LO	REPAIRS & MAINTENANCE	001-4310-4510	41.82
JOHNNY & SON'S, LLC	RO # 17396	LICENSE # 108-8154 VIN # 3	TRANSPORTATION	001-8700-4260	5,025.69
FERRIS JOSEPH PRODUCE, IN	108220	CELERY EA	FOOD SUPPLIES	001-4310-3100	158.28
ROBERT A HAEDGE	17-191	CAUSE # 17-191 ANTHONY L	ADULT - INDIGENT ATTORNE	001-3230-4160	395.00
ROBERT A HAEDGE	17-195	CAUSE # 17-195 RAUSHANI	ADULT - ATTY LITIGATION EX	001-3230-4080	5.00
ROBERT A HAEDGE	17-195	CAUSE # 17-195 RAUSHANI	ADULT - INDIGENT ATTORNE	001-3230-4160	770.00
ROBERT A HAEDGE	17-238	CAUSE # 17-238 JOSHUA ISA	ADULT - ATTY LITIGATION EX	001-3230-4080	580.00
MAILROOM FINANCE, INC	41119	ACCT # 7900 0440 8052 695	OPERATING SUPPLIES	001-4300-3130	212.30
DEWITT POTHS & SON	568893-1	CUST # 12430 BOX, SECURIT	OFFICE SUPPLIES	001-8700-3110	48.45
DEWITT POTHS & SON	568998-0	CUST # 12430 WALLET, 2", A	OFFICE SUPPLIES	001-2150-3110	102.63
DEWITT POTHS & SON	569000-0	CUST # 12430 SPOTPAPER -	OFFICE SUPPLIES	001-2150-3110	144.00

Expense Approval Register

Packet: APPKT03083 - 5/13/19 A/P RUN

Vendor Name	Payable Number	Description (Item)	Account Name	Account Number	Amount
PFG-TEMPLE	9489844	CUST # 435577 DRY GROCER	FOOD SUPPLIES	001-4310-3100	1,563.39
FERRIS JOSEPH PRODUCE, IN	108237	AA MED 15 DOZ EGGS	FOOD SUPPLIES	001-4310-3100	192.10
SYSCO CENTRAL TEXAS, INC	313420554	CUST # 043430 DAIRY/MEAT	FOOD SUPPLIES	001-4310-3100	1,386.43
SYSCO CENTRAL TEXAS, INC	313420554	CUST # 043430 DAIRY/MEAT	OPERATING SUPPLIES	001-4310-3130	60.04
DEWITT POTH & SON	569237-0	CUST # 12430 PAD, EASEL, S	OFFICE SUPPLIES	001-8700-3110	85.73
UNIFIRST CORPORATION	822 2185757	CUST # 222727 RTE # F6140	OPERATING SUPPLIES	001-4310-3130	65.01
UNIFIRST CORPORATION	822 2185821	CUST # 222727 RTE # F6110	CALDWELL CO. COURTHOUS	001-6520-5120	238.97
NEOPOST USA INC	N7682973	CUST # 01054254 2/15 - 5/1	RENTALS	001-6510-4610	340.68
FERRIS JOSEPH PRODUCE, IN	108292	POTATOES 5810 LB BAGGED	FOOD SUPPLIES	001-4310-3100	29.00
O'BANNON FUNERAL HOME	41319	ANDREW GOODWIN / DOD -	INDIGENT FUNERAL	001-7620-4320	595.00
MAILROOM FINANCE, INC	41419	ACCT # 7900 0440 8038 549	POSTAGE INVENTORY	001-1370	470.67
O'BANNON FUNERAL HOME	41419	PATSY MCDONALD / DOD: 4/	INDIGENT FUNERAL	001-7620-4320	595.00
LOCKHART POST REGISTER	00087003	04/04 & 11/19 FOUND	OPERATING SUPPLIES	001-4300-3130	27.88
LOCKHART POST REGISTER	00087005	04/04 & 11/19 TELECOMMU	OPERATING SUPPLIES	001-4300-3130	56.44
CARL R. OHLENDORF INSURA	16911	POLICY 72144998 ACCT # CA	EMPLOYEE BONDING	001-3252-2070	71.00
BOVIK & MEREDITH P.C.	2665-18CC	CAUSE # 2665-18CC / 2687-1	JUVENILE - INDIGENT ATTOR	001-3240-4180	300.00
LOCKHART HARDWARE	28247 /1	CUST # 11239 CORD EXT 12/	CALDWELL CO. COURTHOUS	001-6520-5120	22.76
ELGIN VETERINARY HOSPITA	41119	EQ ACCOUNT # 53123 3/1 -	PROFESSIONAL SERVICES	001-4300-4110	380.90
ALBERTO LUNA	41519	CONFERENCE - FINGER DRU	TRAINING	001-3200-4810	210.00
SMITH SUPPLY CO.-LULING	68703	GELL CELL 12V 7AMP PS1270	LULING ANNEX	001-6520-3510	33.90
SMITH SUPPLY CO.- LOCKHA	806804	SNAP LINK UNCP 5/16 UNCP	JUDICIAL CENTER-LOCKHART	001-6520-3550	8.75
UNIFIRST CORPORATION	822 2186152	CUST # 222727 RTE # F2900	LULING ANNEX	001-6520-3510	46.91
AT & T MOBILITY	875648878X04232019	ACCT # 875648878 BILLING	FAX & INTERNET	001-6510-4425	417.89
PFG-TEMPLE	9492890	CUST # 435577 DRY GROCE	FOOD SUPPLIES	001-4310-3100	1,025.98
FILEX SYSTEMS, INC	99542	FILEX PO# 99169 LEGAL RED	OFFICE SUPPLIES	001-2150-3110	583.00
FERRIS JOSEPH PRODUCE, IN	108309	BANANAS 40 LB CASE	FOOD SUPPLIES	001-4310-3100	145.50
ELSIE LACY	32019	LEARN, GROW, EAT & GO PLI	MILEAGE REIMB- ADH DEMO	001-8700-4251	124.12
OMNIBASE SERVICES OF TEX	41619	1ST QTR 2019 ACTIVITY REP	DUE TO State-Failure to App	001-2730	2,850.00
DEWITT POTH & SON	569461-0	CUST # 12430 MARKER, PER	OFFICE SUPPLIES	001-7610-3110	115.78
DEWITT POTH & SON	569516-0	CUST # 12430 RACK, DSPLY,	OFFICE SUPPLIES	001-3253-3110	172.59
FLOWERS BAKING CO. OF SA	TKT # 2038382017	CUST # 0040078309 MIC 20	FOOD SUPPLIES	001-4310-3100	315.36
FERRIS JOSEPH PRODUCE, IN	108316	ICEBERG 24 CT	FOOD SUPPLIES	001-4310-3100	37.00
VICTOREA D. BROWN	18-297	CAUSE # 18-297 JUAN HERR	ADULT - ATTY LITIGATION EX	001-3230-4080	29.41
VICTOREA D. BROWN	18-297	CAUSE # 18-297 JUAN HERR	ADULT - INDIGENT ATTORNE	001-3230-4160	728.00
SYSCO CENTRAL TEXAS, INC	313433280	CUST # 043430 DAIRY/MEA	FOOD SUPPLIES	001-4310-3100	1,459.97
SYSCO CENTRAL TEXAS, INC	313433280	CUST # 043430 DAIRY/MEA	OPERATING SUPPLIES	001-4310-3130	450.31
SYSCO CENTRAL TEXAS, INC	313433281	CUST # 043430 CHEMICAL &	OPERATING SUPPLIES	001-4310-3130	313.63
CINTAS CORPORATION #86	4020224942	SOLD TO # 13228013 PAYER	UNIFORMS	001-6520-3140	81.02
MAILROOM FINANCE, INC	41719	ACCT # 7900 0440 8038 549	OFFICE SUPPLIES	001-6510-3110	3,000.00
SHANNA CONLEY	42019	MILEAGE FOR TRAINING 4/8	TRAINING	001-3252-4810	50.11
M.B. HAMMO ENTERPRISES,	6621	TOILET PAPER REGULAR / RO	FOOD SUPPLIES	001-4310-3100	575.83
CENTURY A/C SUPPLY	9752294	ORDER # 6568902 OVAL CA	BUILDING MAINTENANCE-LO	001-6520-3600	22.00
MARK'S PLUMBING PARTS	INV001792564	CUST # 278898 FLOW WASH	REPAIRS & MAINTENANCE	001-4310-4510	57.30
BAKER DISTRIBUTING COMP	X737597	CUST # 047519 KIT PUMP 11	JUDICIAL CENTER-LOCKHART	001-6520-3550	234.62
FERRIS JOSEPH PRODUCE, IN	108332	ICEBERG 24 CT	FOOD SUPPLIES	001-4310-3100	105.50
LOCKHART HARDWARE	28325 /1	CUST # 11239 DOWEL FSC 5	BUILDING MAINTENANCE-LO	001-6520-3600	2.78
TEXAS GATE REPAIR	3537	REMOVE AND REPLACE OLD	REPAIRS & MAINTENANCE	001-4310-4510	553.65
DEWITT POTH & SON	569684-0	CUST # 12430 CRTDG, INKJE	OFFICE SUPPLIES	001-6550-3110	33.99
M.B. HAMMO ENTERPRISES,	6574	TOILET PAPER REGULAR / RO	OPERATING SUPPLIES	001-4310-3130	751.40
GRAINGER	9149674062	ACCT # 841505548 PLUG, 12	REPAIRS & MAINTENANCE	001-4310-4510	-3.27
GRAINGER	9150396654	ACCT # 841505548 JOBBER	REPAIRS & MAINTENANCE	001-4310-4510	222.36
PFG-TEMPLE	9496905	CUST # 435577 DRY GROCE	FOOD SUPPLIES	001-4310-3100	1,329.57
FERRIS JOSEPH PRODUCE, IN	108337	GREEN CABBAGE LB	FOOD SUPPLIES	001-4310-3100	185.30
TRAVIS COUNTY CLERK	19-000810	CAUSE # C-1-MH-19-000810	SANITY HEARINGS	001-7620-4312	458.00
SYSCO CENTRAL TEXAS, INC	313439604	CUST # 043430 DAIRY/MEA	FOOD SUPPLIES	001-4310-3100	1,497.59
SYSCO CENTRAL TEXAS, INC	313439604	CUST # 043430 DAIRY/MEA	OPERATING SUPPLIES	001-4310-3130	67.99
AL DOS SANTOS	42019	ACCREDITATION TRAINING 4/	TRAINING	001-6570-4810	112.40
TAYLOR SECURITY SYSTEMS,	77320	ACCT # 60-03-7285F SERVIC	LULING ANNEX	001-6520-3510	225.00
UNIFIRST CORPORATION	822 2188060	CUST # 222727 RTE # F6110	CALDWELL CO. COURTHOUS	001-6520-5120	238.97
LIVENGOD FEED STORE	LOINV000185185	CUST # 1C250 HAY COASTAL	OPERATING SUPPLIES	001-4300-3130	52.50

Expense Approval Register

Packet: APPKT03083 - 5/13/19 A/P RUN

Vendor Name	Payable Number	Description (Item)	Account Name	Account Number	Amount
GALL'S, LLC	ORDER # 12849834-1	GALLS TAC FORCE SQUAD TA	UNIFORMS	001-6640-3140	99.96
GALL'S, LLC	ORDER # 12849834-2	65/35 POLY/COTTON S/S TA	UNIFORMS	001-6640-3140	95.96
FERRIS JOSEPH PRODUCE, IN	108092	BANANAS EA	FOOD SUPPLIES	001-4310-3100	86.10
JOHN DEERE FINANCIAL	1904-012010	ACCT # 1-99 HOE GARDEN	BUILDING MAINTENANCE-LO	001-6520-3600	19.99
FLOWERS BAKING CO. OF SA	2038381797	CUST # 0040078309 MIC 20	FOOD SUPPLIES	001-4310-3100	306.72
LOCKHART HARDWARE	28049 /1	CUST # 11239 COMPACT BA	BUILDING MAINTENANCE-LO	001-6520-3600	89.98
LOCKHART HARDWARE	28060 /1	CUST # 11239 SCREWS, NUT	L.W.SCOTT ANNEX-LOCKHAR	001-6520-3540	13.53
SMITH SUPPLY CO.- LOCKHA	805245	PROPANE FUEL CYLINDER 14	BUILDING MAINTENANCE-LO	001-6520-3600	13.90
SOUTHERN HEALTH PARTNE	BASE35050	CUST ID: CAL-7388 PROVISI	PROFESSIONAL SERVICES	001-4310-4110	39,489.34
XEROX BUSINESS SOLUTION	IN1991875	CONTRACT # CN31402-01 O	RENTALS	001-6510-4610	184.75
MAILROOM FINANCE, INC	INV15699551	ACCT # 7900044080109295	POSTAGE INVENTORY	001-1370	1,142.16
MAILROOM FINANCE, INC	INV15699551	ACCT # 7900044080109295	OFFICE SUPPLIES	001-6510-3110	66.00
FERRIS JOSEPH PRODUCE, IN	108391	APPLES 138CT RED DEL CASE	FOOD SUPPLIES	001-4310-3100	92.00
SPRINT	122236591-121	ACCT # 122236591 3/17 - 4/	TELEPHONE	001-4300-4420	37.99
UNITED RENTALS (NORTH A	166921709-002	CUST # 1331322 SCISSOR LIF	JUDICIAL CENTER-LOCKHART	001-6520-3550	527.70
DEWITT POTH & SON	567469-0	CUST # 12430	MACHINERY AND EQUIPME	001-2120-5310	425.69
DEWITT POTH & SON	569834-0	CUST # 12430 FASTENER, C	OFFICE SUPPLIES	001-3200-3110	272.75
UNIFIRST CORPORATION	822 2188416	CUST # 222727 RTE # F2900	LULING ANNEX	001-6520-3510	46.91
PFG-TEMPLE	95000185	CUST # 435577 DRY GROCE	FOOD SUPPLIES	001-4310-3100	1,290.00
ATCO INTERNATIONAL	10528494	CUST ID: 126786	REPAIRS & MAINTENANCE	001-4310-4510	124.00
GT DISTRIBUTORS, INC.	INV0706979	CUST # 006427 CCI .40S&W	TRAINING	001-4321-4810	17.99
GONZALES BUILDING CENTE	INV0791750	CUST # CALD001 TOWEL M	JUDICIAL CENTER-LOCKHART	001-6520-3550	247.13
FERRIS JOSEPH PRODUCE, IN	108406	CABBAGE GREEN 50 LB JBO S	FOOD SUPPLIES	001-4310-3100	90.00
COTHRON'S SAFE & LOCK	1221851	CUST # CALD119 SERVICE C	CALDWELL CO. COURTHOUS	001-6520-5120	199.70
THE CASEY LAW FIRM	17-115	CAUSE # 17-115 JOSHUA S. H	ADULT - ATTY LITIGATION EX	001-3230-4080	5.00
THE CASEY LAW FIRM	17-115	CAUSE # 17-115 JOSHUA S. H	ADULT - INDIGENT ATTORNE	001-3230-4160	820.00
THE CASEY LAW FIRM	18-205	CAUSE # 18-205 ABNER GRE	ADULT - ATTY LITIGATION EX	001-3230-4080	5.00
THE CASEY LAW FIRM	18-205	CAUSE # 18-205 ABNER GRE	ADULT - INDIGENT ATTORNE	001-3230-4160	450.00
FLOWERS BAKING CO. OF SA	2038382129	CUST # 0040078309 MIC 20	FOOD SUPPLIES	001-4310-3100	315.36
PRINTING SOLUTIONS	21887	BUSINESS CARDS - JUDGE DE	OFFICE SUPPLIES	001-3254-3110	60.00
4 SQUARE COMMUNICATIO	3755	REPLACED CAMERA IN A & B	REPAIRS & MAINTENANCE	001-4310-4510	290.98
OSS ACADEMY	55592R	JAMES BOHAC - PID # 29306	TRAINING	001-4300-4810	65.00
FARMER BROTHERS. CO.	69039709	ACCT # 6302473/6302473 IC	FOOD SUPPLIES	001-4310-3100	450.76
G and C Printing Forms	GC 108460	4000 - 10-24 REG ENVELOPE	OFFICE SUPPLIES	001-3220-3110	225.65
SCHMIDT FIRE & SAFETY CO.	018757	CONSTABLES PRCT #2	LULING ANNEX	001-6520-3510	79.50
SCHMIDT FIRE & SAFETY CO.	018758	FANNIN STREET ANNEX	LULING ANNEX	001-6520-3510	72.00
FERRIS JOSEPH PRODUCE, IN	108418	50 LB JUMBO YELLOW ONIO	FOOD SUPPLIES	001-4310-3100	50.50
SCHOON LAW FIRM, PC	12-060 / 13-195	CAUSE # 12-060 / 13-195 RI	ADULT - ATTY LITIGATION EX	001-3230-4080	0.55
SCHOON LAW FIRM, PC	12-060 / 13-195	CAUSE # 12-060 / 13-195 RI	ADULT - INDIGENT ATTORNE	001-3230-4160	300.00
ROBERT A HAEDGE	14-084	CAUSE # 14-084 JENNIFER M	ADULT - INDIGENT ATTORNE	001-3230-4160	690.00
THE CASEY LAW FIRM	17-172	CAUSE # 17-172 ANTONIO C	ADULT - INDIGENT ATTORNE	001-3230-4160	690.00
LILIANA LEON FORES	18-172	CAUSE # 18-172 RAY GONZA	ADULT - ATTY LITIGATION EX	001-3230-4080	5.00
LILIANA LEON FORES	18-172	CAUSE # 18-172 RAY GONZA	ADULT - INDIGENT ATTORNE	001-3230-4160	530.00
SCHOON LAW FIRM, PC	18-223 / 10-245	CAUSE # 18-223 / 10-245 CH	ADULT - ATTY LITIGATION EX	001-3230-4080	6.50
SCHOON LAW FIRM, PC	18-223 / 10-245	CAUSE # 18-223 / 10-245 CH	ADULT - INDIGENT ATTORNE	001-3230-4160	540.00
SYSCO CENTRAL TEXAS, INC	313452865	CUST # 043430 DAIRY / FRO	FOOD SUPPLIES	001-4310-3100	909.19
SYSCO CENTRAL TEXAS, INC	313452865	CUST # 043430 DAIRY / FRO	OPERATING SUPPLIES	001-4310-3130	234.41
CINTAS CORPORATION #86	4020645519	SOLD TO # 13228013 PAYER	UNIFORMS	001-6520-3140	81.02
LELTON WAYNE MORSE	42019	EXPENSE FORM FOR 4/12 -1	TRANSPORTATION	001-8700-4260	312.33
GEORGE V. C. PARKER	47-426	CAUSE # 47-426 CRESCENTIN	ADULT - EXPERT WITNESS	001-3230-4150	750.00
GEORGE V. C. PARKER	47-426	CAUSE # 47-426 CRESCENTIN	ADULT - EXPERT WITNESS	001-3240-4150	750.00
DEWITT POTH & SON	569834-1	CUST # 12430 TISSUES, ANTI	OFFICE SUPPLIES	001-3200-3110	43.49
DEWITT POTH & SON	570081-0	CUST # 12430 FOLDER, FILE,	OFFICE SUPPLIES	001-3252-3110	56.80
M.B. HAMMO ENTERPRISES,	6656	TOILET PAPER REGULAR / RO	OPERATING SUPPLIES	001-4310-3130	662.37
LOCKHART POST REGISTER	00087230	04/18 & 25/19 FOUND	OPERATING SUPPLIES	001-4300-3130	17.00
JAN FORD MUSTIN PH.D, P.C	04252019	TCOLE EVALUATION, MMPI	EMPLOYEE PHYSICALS	001-4310-4135	295.00
FERRIS JOSEPH PRODUCE, IN	108435	ICEBERG 24 CT	FOOD SUPPLIES	001-4310-3100	99.50
KEYLA ROBERTSON	13-FL-183	CAUSE # 13-FL-183 E.L.	ADULT - INDIGENT ATTORNE	001-3230-4160	1,162.00
SOUTHWEST FILING & STOR	15464-1	300 GOLDENROD CASE BIND	OFFICE SUPPLIES	001-3220-3110	432.60
SOUTHWEST FILING & STOR	15464-2	300 RED CASE BINDERS	OFFICE SUPPLIES	001-3220-3110	432.60

Vendor Name	Payable Number	Description (Item)	Account Name	Account Number	Amount
THE LAW OFFICES OF CARRIE	17-FL-287 9	CAUSE # 17-FL-287 Z.M.R.	ADULT - INDIGENT ATTORNE	001-3230-4160	98.00
CINDY A. DURAN	17-FL-312 4	CAUSE # 17-FL-312 D.C. / E.	ADULT - INDIGENT ATTORNE	001-3230-4160	707.00
GLEN A. GRUNBERGER	17-FL-357	CAUSE # 17-FL-357 N.T. / A.	ADULT - INDIGENT ATTORNE	001-3230-4160	889.00
ZACHARY RICK MANWILL	18-FL-045 4	CAUSE # 18-FL-045 GLASSC	ADULT - INDIGENT ATTORNE	001-3230-4160	392.00
BOVIK & MEREDITH P.C.	18-FL-070 1	CAUSE # 18-FL-070	ADULT - INDIGENT ATTORNE	001-3230-4160	1,260.00
TAHLIA T. STEWART	18-FL-110 5	CAUSE # 18-FL-110 N.A.	ADULT - INDIGENT ATTORNE	001-3230-4160	434.00
THE LAW OFFICES OF CARRIE	18-FL-118 10	CAUSE # 18-FL-118 B.B.S.B.	ADULT - INDIGENT ATTORNE	001-3230-4160	280.00
BOVIK & MEREDITH P.C.	18-FL-118 1	CAUSE # 18-FL-118 B.B.S.B.	ADULT - INDIGENT ATTORNE	001-3230-4160	1,498.00
ZACHARY RICK MANWILL	18-FL-185 2	CAUSE # 18-FL-185 GUTIERR	ADULT - INDIGENT ATTORNE	001-3230-4160	56.00
JANA CLIFT-WILLIAMS	18-FL-192 6	CAUSE # 18-FL-192 R.G.	ADULT - INDIGENT ATTORNE	001-3230-4160	119.00
ADAM D. ROWINS	18-FL-192	CAUSE # 18-FL-192 R.S.S.G.	ADULT - INDIGENT ATTORNE	001-3230-4160	126.00
ZACHARY RICK MANWILL	18-FL-281 2	CAUSE # 18-FL-281 Z.M.MF	ADULT - INDIGENT ATTORNE	001-3230-4160	126.00
ZACHARY RICK MANWILL	18-FL-288 1	CAUSE # 18-FL-288 C.C.C-F	ADULT - INDIGENT ATTORNE	001-3230-4160	119.00
JANA CLIFT-WILLIAMS	18-FL-309 4	CAUSE # 18-FL-309 Z.R.	ADULT - INDIGENT ATTORNE	001-3230-4160	70.00
THE LAW OFFICES OF CARRIE	18-FL-312 2	CAUSE # 18-FL-312 I./G.	ADULT - INDIGENT ATTORNE	001-3230-4160	70.00
THE LAW OFFICES OF CARRIE	18-FL-317 1	CAUSE # 18-FL-317 VASQUE	ADULT - INDIGENT ATTORNE	001-3230-4160	140.00
ZACHARY RICK MANWILL	18-FL-317 3	CAUSE # 18-FL-317 K.V.	ADULT - INDIGENT ATTORNE	001-3230-4160	826.00
ADAM D. ROWINS	18-FL-317 6	CAUSE # 18-FL-317 K.V.	ADULT - INDIGENT ATTORNE	001-3230-4160	343.00
ADOPTION LAW FIRM OF TE	18-FL-317	CAUSE # 18-FL-317 K.V./U.G.	ADULT - INDIGENT ATTORNE	001-3230-4160	420.00
BOVIK & MEREDITH P.C.	18-FL-318	CAUSE # 18-FL-318 J.H.	ADULT - INDIGENT ATTORNE	001-3230-4160	906.50
ZACHARY RICK MANWILL	18-FL-330 2	CAUSE # 18-FL-330 T.G.J. / K	ADULT - INDIGENT ATTORNE	001-3230-4160	35.00
BOVIK & MEREDITH P.C.	18-FL-446	CAUSE # 18-FL-446 J.M.	ADULT - INDIGENT ATTORNE	001-3230-4160	122.50
THE LAW OFFICES OF CARRIE	18-FL-448 4	CAUSE # 18-FL-448 PG & JG	ADULT - INDIGENT ATTORNE	001-3230-4160	378.00
JANA CLIFT-WILLIAMS	18-FL-448 5	CAUSE # 18-FL-448 P.G /J.G.	ADULT - INDIGENT ATTORNE	001-3230-4160	399.00
ZACHARY RICK MANWILL	18-FL-474 1	CAUSE # 18-FL-474 I.J.	ADULT - INDIGENT ATTORNE	001-3230-4160	210.00
LARRY O. RASCO	18-FL-474	CAUSE # 18-FL-474 J. CHILD	ADULT - INDIGENT ATTORNE	001-3230-4160	225.00
KEYLA ROBERTSON	18-FL-488	CAUSE # 18-FL-488 A.E.	ADULT - INDIGENT ATTORNE	001-3230-4160	595.00
CINDY A. DURAN	18-FL-503 1	CAUSE # 18-FL-503 A.C./B.C.	ADULT - INDIGENT ATTORNE	001-3230-4160	231.00
JANA CLIFT-WILLIAMS	18-FL-539 2	CAUSE # 18-FL-539 N.M.	ADULT - INDIGENT ATTORNE	001-3230-4160	266.00
ADAM D. ROWINS	18-FL-539 3	CAUSE # 18-FL-539 N.C.M.	ADULT - INDIGENT ATTORNE	001-3230-4160	126.00
JANA CLIFT-WILLIAMS	18-FL-595 2	CAUSE # 18-FL-595 L.G.	ADULT - INDIGENT ATTORNE	001-3230-4160	105.00
TAHLIA T. STEWART	19-FL-005 2	CAUSE # 19-FL-005 V.M. / D	ADULT - INDIGENT ATTORNE	001-3230-4160	441.00
ZACHARY RICK MANWILL	19-FL-005	CAUSE # 19-FL-005 D & V. M	ADULT - INDIGENT ATTORNE	001-3230-4160	238.00
CINDY A. DURAN	19-FL-027 1	CAUSE # 19-FL-027 G.H.G /	ADULT - INDIGENT ATTORNE	001-3230-4160	294.00
ZACHARY RICK MANWILL	19-FL-027	CAUSE # 19-FL-027 G.H.G. /	ADULT - INDIGENT ATTORNE	001-3230-4160	336.00
THE LAW OFFICES OF CARRIE	19-FL-047 1	CAUSE # 1-FL-047 G/M	ADULT - INDIGENT ATTORNE	001-3230-4160	259.00
ADAM D. ROWINS	19-FL-047 2	CAUSE # 19-FL-047 J.G. / M.	ADULT - INDIGENT ATTORNE	001-3230-4160	77.00
ADOPTION LAW FIRM OF TE	19-FL-047	CAUSE # 19-FL-047 M.H. / J.	ADULT - INDIGENT ATTORNE	001-3230-4160	238.00
ZACHARY RICK MANWILL	19-FL-047	CAUSE # 19-FL-047 J.G. / M.	ADULT - INDIGENT ATTORNE	001-3230-4160	161.00
JANA CLIFT-WILLIAMS	19-FL-054 1	CAUSE # 19-FL-054 D.R.	ADULT - INDIGENT ATTORNE	001-3230-4160	182.00
ADAM D. ROWINS	19-FL-074 1	CAUSE # 19-FL-074 A.S.	ADULT - INDIGENT ATTORNE	001-3230-4160	77.00
KEYLA ROBERTSON	19-FL-074	CAUSE # 19-FL-074 A.S.	ADULT - INDIGENT ATTORNE	001-3230-4160	539.00
GLENN WILLIAMS	19-FL-086	CAUSE # 19-FL-086 D.L. / F.L	ADULT - INDIGENT ATTORNE	001-3230-4160	175.00
CINDY A. DURAN	19-FL-086	CAUSE # 19-FL-086 D.L./F.L.	ADULT - INDIGENT ATTORNE	001-3230-4160	350.00
JANA CLIFT-WILLIAMS	19-FL-086	CAUSE # 19-FL-086 D.L.	ADULT - INDIGENT ATTORNE	001-3230-4160	77.00
ADOPTION LAW FIRM OF TE	19-FL-091	CAUSE # 19-FL-091 J.S./O.S./	ADULT - INDIGENT ATTORNE	001-3230-4160	224.00
JANA CLIFT-WILLIAMS	19-FL-091	CAUSE # 19-FL-091 J.S.	ADULT - INDIGENT ATTORNE	001-3230-4160	119.00
THE LAW OFFICES OF CARRIE	19-FL-103	CAUSE # 19-FL-103 O.	ADULT - INDIGENT ATTORNE	001-3230-4160	203.00
ADAM D. ROWINS	19-FL-103	CAUSE # 19-FL-103 O.O.JR/A	ADULT - INDIGENT ATTORNE	001-3230-4160	196.00
ZACHARY RICK MANWILL	19-FL-104	CAUSE # 19-FL-104 D.S.	ADULT - INDIGENT ATTORNE	001-3230-4160	385.00
CINDY A. DURAN	19-FL-146	CAUSE # 19-FL-146 C.E.J.	ADULT - INDIGENT ATTORNE	001-3230-4160	973.00
KEYLA ROBERTSON	1-FL-104	CAUSE # 19-FL-104 D.S.	ADULT - INDIGENT ATTORNE	001-3230-4160	1,673.00
TEXAS COLLEGE OF PROBATE	52109	TERESA RODRIGUEZ - 5/30-3	TRAINING	001-2150-4810	375.00
DEWITT POTH & SON	570271-0	CUST # 12430 BOARD, CORK	OFFICE SUPPLIES	001-8700-3110	54.66
DEWITT POTH & SON	570274-0	CUST # 12430 FOLDER, INTE	OFFICE SUPPLIES	001-3251-3110	193.60
PFG-TEMPLE	9503895	CUST # 435577 DRY GROCER	FOOD SUPPLIES	001-4150-3100	768.56
HOTEL GALVEZ & SPA	CONF # 18896710	TERESA RODRIGUEZ - 5/29 -	TRAINING	001-2150-4810	285.20
JAN FORD MUSTIN PH.D, P.C	04262019	TCOLE EVALUATION, MMPI	EMPLOYEE PHYSICALS	001-4310-4135	295.00
FERRIS JOSEPH PRODUCE, IN	108439	ICEBERG 24 CT	FOOD SUPPLIES	001-4310-3100	226.40
LARRY O. RASCO	18-FL-070	CAUSE # 18-FL-070 A.W.	ADULT - INDIGENT ATTORNE	001-3230-4160	910.00

Expense Approval Register

Packet: APPKT03083 - 5/13/19 A/P RUN

Vendor Name	Payable Number	Description (Item)	Account Name	Account Number	Amount
JANA CLIFT-WILLIAMS	18-FL-488 4	CAUSE # 18-FL-488 A.E.	ADULT - INDIGENT ATTORNE	001-3230-4160	77.00
SCHMIDT FIRE & SAFETY CO.	19054	SCOTT ANNEX BLDG	L.W.SCOTT ANNEX-LOCKHAR	001-6520-3540	87.00
SCHMIDT FIRE & SAFETY CO.	19055	ENVIRONMENTAL	MARKET ST. ANNEX-LOCKHA	001-6520-3530	4.00
SCHMIDT FIRE & SAFETY CO.	19056	JUVENILE DETENTION	JUVENILE DETENTION CTR.-L	001-6520-3580	12.00
SCHMIDT FIRE & SAFETY CO.	19057	DRC	JP1/DRC BUILDING-LOCKHA	001-6520-3560	12.00
SCHMIDT FIRE & SAFETY CO.	19058	MAINTENANCE	BUILDING MAINTENANCE-LO	001-6520-3600	58.00
SCHMIDT FIRE & SAFETY CO.	19059	405 E MARKET	MARKET ST. ANNEX-LOCKHA	001-6520-3530	8.00
SCHMIDT FIRE & SAFETY CO.	19060	RED SHOW BARN	BUILDING MAINTENANCE-LO	001-6520-3600	8.00
SCHMIDT FIRE & SAFETY CO.	19061	OFFICE OF EMERGENCY MG	L.W.SCOTT ANNEX-LOCKHAR	001-6520-3540	74.00
SCHMIDT FIRE & SAFETY CO.	19062	PRCT # 1	JP1/DRC BUILDING-LOCKHA	001-6520-3560	4.00
SCHMIDT FIRE & SAFETY CO.	19063	COURTHOUSE	CALDWELL CO. COURTHOUS	001-6520-5120	52.00
SCHMIDT FIRE & SAFETY CO.	19064	EXTENTION AGENT TRUCK	L.W.SCOTT ANNEX-LOCKHAR	001-6520-3540	4.00
SCHMIDT FIRE & SAFETY CO.	19065	PRCT # 3 OFFICE	JP3 SIMON BUILDING-MAXW	001-6520-3500	4.00
SYSCO CENTRAL TEXAS, INC	313459501	CUST # 043430 DAIRY / MEA	FOOD SUPPLIES	001-4310-3100	1,641.70
SYSCO CENTRAL TEXAS, INC	313459501	CUST # 043430 DAIRY / MEA	OPERATING SUPPLIES	001-4310-3130	86.97
4 SQUARE COMMUNICATIO	3772	OUTDOOR CAMERA VARIFO	REPAIRS & MAINTENANCE	001-4310-4510	760.00
DEWITT POTH & SON	570345-0	SYSTEM # 8299 SERIAL # C2C	OFFICE SUPPLIES	001-6550-3110	31.56
UNIFIRST CORPORATION	822 2190217	CUST # 222727 RTE # F6140	OPERATING SUPPLIES	001-4310-3130	65.01
UNIFIRST CORPORATION	822 2190277	CUST # 222727 RTE # F6110	CALDWELL CO. COURTHOUS	001-6520-5120	238.97
DAVID BROOKS, ATTORNEY	42019	LEGAL CONSULTATION SERVI	PUBLICATIONS	001-3200-4315	100.00
UNIFIRST CORPORATION	822 2190619	CUST # 222727 RTE # 2 PRC	LULING ANNEX	001-6520-3510	46.91
FLEETCOR TECHNOLOGIES, I	NP55933650	ACCT # BG114286 3/25 - 4/2	DUE FROM C C A D	001-1260	122.52
FLEETCOR TECHNOLOGIES, I	NP55933650	ACCT # BG114286 3/25 - 4/2	TRANSPORTATION	001-3200-4260	164.04
FLEETCOR TECHNOLOGIES, I	NP55933650	ACCT # BG114286 3/25 - 4/2	TRANSPORTATION	001-4300-4260	10,729.11
FLEETCOR TECHNOLOGIES, I	NP55933650	ACCT # BG114286 3/25 - 4/2	TRANSPORTATION	001-4310-4260	1,302.60
FLEETCOR TECHNOLOGIES, I	NP55933650	ACCT # BG114286 3/25 - 4/2	TRANSPORTATION	001-4321-4260	645.03
FLEETCOR TECHNOLOGIES, I	NP55933650	ACCT # BG114286 3/25 - 4/2	TRANSPORTATION	001-4322-4260	698.11
FLEETCOR TECHNOLOGIES, I	NP55933650	ACCT # BG114286 3/25 - 4/2	TRANSPORTATION	001-4323-4260	428.74
FLEETCOR TECHNOLOGIES, I	NP55933650	ACCT # BG114286 3/25 - 4/2	TRANSPORTATION	001-4324-4260	274.08
FLEETCOR TECHNOLOGIES, I	NP55933650	ACCT # BG114286 3/25 - 4/2	MISCELLANEOUS	001-6510-4850	110.48
FLEETCOR TECHNOLOGIES, I	NP55933650	ACCT # BG114286 3/25 - 4/2	TRANSPORTATION	001-6520-4260	557.18
FLEETCOR TECHNOLOGIES, I	NP55933650	ACCT # BG114286 3/25 - 4/2	TRANSPORTATION	001-6640-4260	256.52
FLEETCOR TECHNOLOGIES, I	NP55933650	ACCT # BG114286 3/25 - 4/2	TRANSPORTATION	001-6650-4260	693.69
FLEETCOR TECHNOLOGIES, I	NP55933650	ACCT # BG114286 3/25 - 4/2	TRANSPORTATION	001-7610-4260	142.32
FLEETCOR TECHNOLOGIES, I	NP55933650	ACCT # BG114286 3/25 - 4/2	TRANSPORTATION	001-8700-4260	141.83
AERODYNAMICS AIRCONDITI	1162	REPLACED FAN MOTOR ON	REPAIRS & MAINTENANCE	001-4310-4510	470.00
LOCKHART HARDWARE	28072 /1	CUST # 11239 TOILET SEAT E	MARKET ST. ANNEX-LOCKHA	001-6520-3530	25.98
SYSCO CENTRAL TEXAS, INC	313394424	CUST# 043430 CHEMICAL &	OPERATING SUPPLIES	001-4310-3130	313.63
SYSCO CENTRAL TEXAS, INC	313394425	CUST # 043430 DAIRY/MEAT	FOOD SUPPLIES	001-4310-3100	-106.93
SYSCO CENTRAL TEXAS, INC	313394425	CUST # 043430 DAIRY/MEAT	OPERATING SUPPLIES	001-4310-3130	380.65
SYSCO CENTRAL TEXAS, INC	313394425	CUST # 043430 DAIRY/MEAT	OPERATING SUPPLIES	001-4310-3130	-19.49
SYSCO CENTRAL TEXAS, INC	313394425	CUST # 043430 DAIRY/MEAT	OPERATING SUPPLIES	001-4310-3130	-33.97
SYSCO CENTRAL TEXAS, INC	313394425	CUST # 043430 DAIRY/MEAT	OPERATING SUPPLIES	001-4310-3130	1,716.74
CINTAS CORPORATION #86	4019388436	SOLD TO # 13228013 PAYER	UNIFORMS	001-6520-3140	81.02
T7 ENTERPRISES, LLC	5573	PASSENGER/LIGHT TRUCK	DISPOSAL FEES	001-6640-3151	296.00
SMITH SUPPLY CO.- LOCKHA	805382	STAKE NAIL 18 INCH WPS118	L.W.SCOTT ANNEX-LOCKHAR	001-6520-3540	24.50
SMITH SUPPLY CO.- LOCKHA	805424	CEMENT - READY MIX 80#	L.W.SCOTT ANNEX-LOCKHAR	001-6520-3540	39.80
TEXAS STATE NOTARY BURE	131972105	FILE # 131972105 AMY TYNA	OFFICE SUPPLIES	001-3252-3110	30.99
CARD SERVICE CENTER	40119	CARD ENDS W/1237 APRIL	DUES & SUBSCRIPTIONS	001-3200-3050	240.00
CARD SERVICE CENTER	40119	CARD ENDS W/1237 APRIL	DUES & SUBSCRIPTIONS	001-3200-3050	240.00
CARD SERVICE CENTER	40119	CARD ENDS W/1237 APRIL	DUES & SUBSCRIPTIONS	001-3200-3050	240.00
CARD SERVICE CENTER	40119	CARD ENDS W/1237 APRIL	DUES & SUBSCRIPTIONS	001-3200-3050	240.00
CARD SERVICE CENTER	40119	CARD ENDS W/1237 APRIL	DUES & SUBSCRIPTIONS	001-3200-3050	240.00
CARD SERVICE CENTER	40119	CARD ENDS W/1237 APRIL	DUES & SUBSCRIPTIONS	001-3200-3050	240.00
CARD SERVICE CENTER	40119	CARD ENDS W/1237 APRIL	DUES & SUBSCRIPTIONS	001-3200-3050	240.00
CARD SERVICE CENTER	40119	CARD ENDS W/1237 APRIL	DUES & SUBSCRIPTIONS	001-3200-3050	240.00
CARD SERVICE CENTER	40119	CARD ENDS W/1237 APRIL	TRAINING	001-3200-4810	572.25
CARD SERVICE CENTER	40119	CARD ENDS W/1237 APRIL	JUROR EXPENSE	001-3230-4820	53.64
CARD SERVICE CENTER	40119	CARD ENDS W/1237 APRIL	POSTAGE	001-3251-3120	20.84
CARD SERVICE CENTER	40119	CARD ENDS W/1237 APRIL	OFFICE SUPPLIES	001-3252-3110	227.78
CARD SERVICE CENTER	40119	CARD ENDS W/1237 APRIL	OFFICE SUPPLIES	001-3254-3110	140.71

Expense Approval Register

Packet: APPKT03083 - 5/13/19 A/P RUN

Vendor Name	Payable Number	Description (Item)	Account Name	Account Number	Amount
CARD SERVICE CENTER	40119	CARD ENDS W/1237 APRIL	OFFICE SUPPLIES	001-3254-3110	23.86
CARD SERVICE CENTER	40119	CARD ENDS W/1237 APRIL	OPERATING SUPPLIES	001-6520-3130	41.27
CARD SERVICE CENTER	40119	CARD ENDS W/1237 APRIL	OPERATING SUPPLIES	001-6520-3130	219.90
CARD SERVICE CENTER	40119	CARD ENDS W/1237 APRIL	BUILDING MAINTENANCE-LO	001-6520-3600	45.59
CARD SERVICE CENTER	40119	CARD ENDS W/1237 APRIL	BUILDING MAINTENANCE-LO	001-6520-3600	499.00
CARD SERVICE CENTER	40119	CARD ENDS W/1237 APRIL	GROUND UPKEEP	001-6520-4440	14.35
CARD SERVICE CENTER	40119	CARD ENDS W/1237 APRIL	CALDWELL CO. COURTHOUS	001-6520-5120	72.00
CARD SERVICE CENTER	40119	CARD ENDS W/1237 APRIL	CALDWELL CO. COURTHOUS	001-6520-5120	194.45
CARD SERVICE CENTER	40119	CARD ENDS W/1237 APRIL	TRANSPORTATION	001-6560-4260	50.00
CARD SERVICE CENTER	40119	CARD ENDS W/1237 APRIL	TRAINING	001-6570-4810	234.06
CARD SERVICE CENTER	40119	CARD ENDS W/1237 APRIL	REPAIRS & MAINTENANCE	001-6610-4510	111.96
CARD SERVICE CENTER	40119	CARD ENDS W/1237 APRIL	REPAIRS & MAINTENANCE	001-6610-4510	32.97
CARD SERVICE CENTER	40119	CARD ENDS W/1237 APRIL	REPAIRS & MAINTENANCE	001-6610-4510	28.26
CARD SERVICE CENTER	40119	CARD ENDS W/1237 APRIL	TRAINING	001-6630-4810	199.00
CARD SERVICE CENTER	40119	CARD ENDS W/1237 APRIL	OFFICE SUPPLIES	001-6650-3110	27.98
CARD SERVICE CENTER	40119	CARD ENDS W/1237 APRIL	OFFICE SUPPLIES	001-6650-3110	193.16
CARD SERVICE CENTER	40119	CARD ENDS W/1237 APRIL	TRAINING	001-6650-4810	752.24
CARD SERVICE CENTER	40119	CARD ENDS W/1237 APRIL	TRAINING	001-6650-4810	200.00
CARD SERVICE CENTER	40119	CARD ENDS W/1237 APRIL	TRAINING	001-6650-4810	200.00
CARD SERVICE CENTER	40119	CARD ENDS W/1237 APRIL	TRAINING	001-6650-4810	644.00
DARLA LAW	42019	MILEAGE FOR APRIL 2019	TRANSPORTATION	001-2140-4260	236.64
BAKER DISTRIBUTING COMP	X855100	CUST # 047519 SCALE STICK	BUILDING MAINTENANCE-LO	001-6520-3600	224.64
HOYT ENTERPRISES, INC	045103	PO # JS01-10-19 FLOW TEST	REPAIRS & MAINTENANCE	001-4310-4510	250.00
FERRIS JOSEPH PRODUCE, IN	108123	RED CABBAGE LB	FOOD SUPPLIES	001-4310-3100	112.80
SCHOON LAW FIRM, PC	12-205	CAUSE # 12-205 JOSE TRINI	ADULT - ATTY LITIGATION EX	001-3230-4080	0.50
SCHOON LAW FIRM, PC	12-205	CAUSE # 12-205 JOSE TRINI	ADULT - INDIGENT ATTORNE	001-3230-4160	300.00
TXTAG	195918322242	ACCT # 442026564 PLATE #	MISCELLANEOUS	001-6510-4850	14.63
PRINTING SOLUTIONS	21778	# 10 REG ENV RAYMOND DE	OFFICE SUPPLIES	001-3254-3110	136.50
PRINTING SOLUTIONS	21779	COPIES - COLOR COPIES D20	OFFICE SUPPLIES	001-6550-3110	20.70
GA POWERS	34292	PART # SLOAN 111 CLOSET R	JUDICIAL CENTER-LOCKHART	001-6520-3550	287.42
GRAINGER	9136155695	ACCT # 841505548 DUPLEX	REPAIRS & MAINTENANCE	001-4310-4510	-1.30
PFG-TEMPLE	9482712	CUST # 435577 DRY GROCE	FOOD SUPPLIES	001-4310-3100	1,126.27
FERRIS JOSEPH PRODUCE, IN	108128	AA MED 15 DOZ EGGS	FOOD SUPPLIES	001-4310-3100	194.25
PB ELECTRONICS INC.	136587	HR-12 SWITCH ASSEMBLY B	MACHINERY AND EQUIPME	001-4324-5310	241.50
SCHOON LAW FIRM, PC	201901-0039	CAUSE # 201901-0039 JOYC	ADULT - ATTY LITIGATION EX	001-3230-4080	0.50
SCHOON LAW FIRM, PC	201901-0039	CAUSE # 201901-0039 JOYC	ADULT - INDIGENT ATTORNE	001-3230-4160	170.00
BLUEBONNET TRAILS MHMR	27-03-2019	ANASAZI VENDOR # 5915 M	PROFESSIONAL SERVICES	001-4310-4110	800.00
LOCKHART HARDWARE	28113 /1	CUST # 11239 CONCRETE CR	L.W.SCOTT ANNEX-LOCKHAR	001-6520-3540	9.99
SYSCO CENTRAL TEXAS, INC	313400955	CUST # 043430 DAIRY/MEA	FOOD SUPPLIES	001-4310-3100	1,247.93
AT&T	4052019	ACCT # 512 A13-0189 725 3	FAX & INTERNET	001-6510-4425	6,250.14
BRANDI VINKLAREK	452019	GALVESTON TRAINING 3/31	TRAINING	001-4310-4810	65.00
UNIFIRST CORPORATION	822 2183516	CUST # 222727 RTE # F6140	OPERATING SUPPLIES	001-4310-3130	65.01
UNIFIRST CORPORATION	822 2183785	CUST # 222727 RTE # G6580	JP3 SIMON BUILDING-MAXW	001-6520-3500	42.73
FERRIS JOSEPH PRODUCE, IN	108177	BANANAS EA	FOOD SUPPLIES	001-4310-3100	178.00
FERRIS JOSEPH PRODUCE, IN	108188	BANANAS EA	FOOD SUPPLIES	001-4310-3100	91.50
THE LAW OFFICES OF JASON	17-189	CAUSE # 17-189 CHRISTOPH	ADULT - ATTY LITIGATION EX	001-3230-4080	5.00
THE LAW OFFICES OF JASON	17-189	CAUSE # 17-189 CHRISTOPH	ADULT - INDIGENT ATTORNE	001-3230-4160	450.00
ON CALL MOBILE VETERINA	2019-04-08	CASE # 2019 03 0103 DUN Q	PROFESSIONAL SERVICES	001-4300-4110	71.00
LOCKHART HARDWARE	28144 /1	CUST # 11239 LIQTITE FIT 90	L.W.SCOTT ANNEX-LOCKHAR	001-6520-3540	45.52
SMITH SUPPLY CO.- LOCKHA	805926	GLOSS WINTER GRAY SPRAY	REPAIRS & MAINTENANCE	001-4310-4510	14.85
PFG-TEMPLE	9485838	CUST # 435577 DRY GROCE	FOOD SUPPLIES	001-4310-3100	940.13
FERRIS JOSEPH PRODUCE, IN	108195	ICEBERG 24 CT	FOOD SUPPLIES	001-4310-3100	70.00
WALTER S. DEAN, SR.	18-307	CAUSE # 18-307 OTABIANO	ADULT - ATTY LITIGATION EX	001-3230-4080	5.00
WALTER S. DEAN, SR.	18-307	CAUSE # 18-307 OTABIANO	ADULT - INDIGENT ATTORNE	001-3230-4160	750.00
WALTER S. DEAN, SR.	2018-219	CAUSE # 2018-219 OTABINO	ADULT - ATTY LITIGATION EX	001-3230-4080	5.00
WALTER S. DEAN, SR.	2018-219	CAUSE # 2018-219 OTABINO	ADULT - INDIGENT ATTORNE	001-3230-4160	750.00
LOCKHART HARDWARE	28166 /1	CUST # 11239 ACE ANGLE P	JUDICIAL CENTER-LOCKHART	001-6520-3550	4.59
FARMER BROTHERS. CO.	69005340	ACCT # 6302473 BLACK SWT	FOOD SUPPLIES	001-4310-3100	357.76
GRAINGER	9141043142	ACCT # 841505548 KNOB LO	REPAIRS & MAINTENANCE	001-4310-4510	468.14
NEOPOST USA INC	N7675862	CUST # 01054254 CCJC 4/11	RENTALS	001-6510-4610	322.30

Expense Approval Register

Packet: APPKT03083 - 5/13/19 A/P RUN

Vendor Name	Payable Number	Description (Item)	Account Name	Account Number	Amount
FLOWERS BAKING CO. OF SA	TKT #2038381902	CUST # 0040078309 MIC 20	FOOD SUPPLIES	001-4310-3100	373.68
BLUEBONNET TRAILS MHMR	102018	TRAINING IN MENTAL HEALT	TRAINING	001-4310-4810	525.00
TRANSUNION RISK AND ALT	234599-201904-1	ACCT # 234599 APRIL 2019	DUES & SUBSCRIPTIONS	001-3200-3050	50.00
CINTAS CORPORATION #86	4021073586	SOLD TO# 13228013 PAYER	UNIFORMS	001-6520-3140	97.27
DENNIS ENGELKE	42019	TRAVEL FOR 4/2 - 29/19	TRANSPORTATION	001-6630-4260	177.83
SMITH SUPPLY CO.- LOCKHA	808544	TEE HINGES 3" ZC CD	CALDWELL CO. COURTHOUS	001-6520-5120	7.00
SECURITY ONE, INC	870765	CUST # 805335 ALARM MON	JP3 SIMON BUILDING-MAXW	001-6520-3500	25.00
TEXAS ASSOCIATION OF COU	MEMBER ID: 216078	TINA M. FREEMAN - 6/23 - 2	TRAINING	001-3220-4810	275.00
KAREN SPHAR	32519	MILEAGE FOR 3/25/19	TRANSPORTATION	001-3200-4260	37.12
AMANDA MONTGOMERY	42519	MILEAGE FOR 4/25/19	TRANSPORTATION	001-3200-4260	40.94
CALDWELL COUNTY APPRAIS	522019	REIMBURSEMENT REQUEST	PROFESSIONAL SERVICES	001-2140-4110	2,176.55
BOB BUSH	522019	SHRM - PROFESSIONAL MEM	TRAINING	001-6580-4810	189.00
					207,603.77
Fund 001 - GENERAL FUND Total:					207,603.77
Fund: 002 - UNIT ROAD FUND					
CINTAS CORPORATION #86	40162593352 C	OVERPAYMENT STATEMENT	UNIFORMS	002-1101-2140	-64.41
CINTAS CORPORATION #86	4016239308 C	OVERPAYMENT ON STATEM	UNIFORMS	002-1101-2140	-2.21
CINTAS CORPORATION #86	3112019 CORRECTION	REPAY 4008458845 & 40084	UNIFORMS	002-1101-2140	833.29
O'REILLY AUTOMOTIVE, INC.	0642-258545	ACCT # 188092 NATIONAL -	SUPPLIES & SMALL TOOLS	002-1102-3136	-64.92
CAPITOL AUTO PARTS	07MB4457	CUST # L10358 AIR FILTER -	OPERATING SUPPLIES	002-1103-3135	37.73
O'REILLY AUTOMOTIVE, INC.	0642-260503	CUST # 188092 TAIL LIGHT K	SUPPLIES & SMALL TOOLS	002-1102-3136	27.99
CAPITOL AUTO PARTS	07MB5734	CUST # L10358 FILTER-AIR D	OPERATING SUPPLIES	002-1103-3135	66.90
O'REILLY AUTOMOTIVE, INC.	0642-260663	CUST # 188092 REPAIR KIT	SUPPLIES & SMALL TOOLS	002-1102-3136	10.98
O'REILLY AUTOMOTIVE, INC.	0642-260667	CUST # 188092 AIR FILTER	SUPPLIES & SMALL TOOLS	002-1102-3136	16.96
O'REILLY AUTOMOTIVE, INC.	0642-260865	CUST # 188092 IDLER PULLE	SUPPLIES & SMALL TOOLS	002-1102-3136	65.10
O'REILLY AUTOMOTIVE, INC.	0642-260873	CUST # 188092 IDLER PULLE	SUPPLIES & SMALL TOOLS	002-1102-3136	-31.48
CAPITOL AUTO PARTS	07MB6927	CUST # L10358 SUPER CONC	OPERATING SUPPLIES	002-1103-3135	91.67
O'REILLY AUTOMOTIVE, INC.	0642-261056	CUST # 188092 ALTERNATO	SUPPLIES & SMALL TOOLS	002-1102-3136	327.56
O'REILLY AUTOMOTIVE, INC.	0642-261081	CUST # 188092 HOSE 3/4"	SUPPLIES & SMALL TOOLS	002-1102-3136	59.99
CAPITOL AUTO PARTS	07MB7601	CUST # L10358 OIL FILTER	OPERATING SUPPLIES	002-1103-3135	3.37
SMITH SUPPLY CO.- LOCKHA	805148	CHAPIN POLY SPRAYER 3GL	OPERATING SUPPLIES	002-1101-3130	23.95
O'REILLY AUTOMOTIVE, INC.	0642-263450	CUST # 188092 AC CONDENS	SUPPLIES & SMALL TOOLS	002-1102-3136	144.78
O'REILLY AUTOMOTIVE, INC.	0642-263469	CUST # 188092 SEAT COVER	SUPPLIES & SMALL TOOLS	002-1102-3136	40.99
O'REILLY AUTOMOTIVE, INC.	0642-263489	CUST # 188092 AC CONDEN	SUPPLIES & SMALL TOOLS	002-1102-3136	-185.77
CAPITOL AUTO PARTS	07MC2671	CUST # L10358 BENDIX PRE	OPERATING SUPPLIES	002-1103-3135	241.46
SEAN MATTHEW MANN	099391	ACCT # 2010 AIR CONDITIO	SUPPLIES & SMALL TOOLS	002-1102-3136	129.99
PETROLEUM TRADERS CORP	1388430	ACCT # 9901644/1 ULTRA LO	FUEL	002-1101-3163	5,528.24
JOHN DEERE FINANCIAL	1904 018068	ACCT # 1-99 SCREWDRIVER	OPERATING SUPPLIES	002-1101-3130	113.31
LOCKHART HARDWARE	28184 /1	CUST # 11239 HVY DUTY CA	OPERATING SUPPLIES	002-1101-3130	14.98
CINTAS CORPORATION #86	4019800536	SOLD TO # 13232664 PAYER	UNIFORMS	002-1101-2140	212.70
CINTAS CORPORATION #86	4019800558	SOLD TO # 13228849 PAYER	UNIFORMS	002-1101-2140	321.89
CINTAS CORPORATION #86	4019800574	SOLD TO: 13232687 PAYER #	UNIFORMS	002-1101-2140	141.61
CINTAS CORPORATION #86	4019800689	SOLD TO # 13228085 PAYER	UNIFORMS	002-1103-2140	76.69
O'REILLY AUTOMOTIVE, INC.	0642-263702	CUST # 188092 SEAT	SUPPLIES & SMALL TOOLS	002-1102-3136	357.14
O'REILLY AUTOMOTIVE, INC.	0642-263717	CUST # 188092 1 GAL ANTI F	SUPPLIES & SMALL TOOLS	002-1102-3136	10.99
CAPITOL AUTO PARTS	07MC3445	CUST # L310 HARMONIC BA	SUPPLIES & SMALL TOOLS	002-1102-3136	113.47
LOCKHART HARDWARE	28203 /1	CUST # 11239 RYL EXT SAT L	OPERATING SUPPLIES	002-1101-3130	111.87
LOCKHART HARDWARE	28213 /1	CUST # 11239 SPRYPNT DUA	OPERATING SUPPLIES	002-1101-3130	62.30
SMITH SUPPLY CO.- LOCKHA	806355	TORPEDO LEVEL STNLY 9"	OPERATING SUPPLIES	002-1101-3130	58.26
O'REILLY AUTOMOTIVE, INC.	0642-263836	CUST # 188092 COOLANT H	SUPPLIES & SMALL TOOLS	002-1102-3136	16.64
CAPITOL AUTO PARTS	07MC3946	CUST # L10358 PREMIUM C	OPERATING SUPPLIES	002-1103-3135	11.05
LOCKHART HARDWARE	28219 /1	CUST # 11239 ACE PAINT BR	OPERATING SUPPLIES	002-1101-3130	47.75
SMITH SUPPLY CO.- LOCKHA	806564	SQUARE TUBE 1-1/2" X 20' 1	OPERATING SUPPLIES	002-1101-3130	32.00
VINYL CONNECTION	931	15" X 50 YDS ENGINEER GRA	OPERATING SUPPLIES	002-1101-3130	492.00
SEAN MATTHEW MANN	099504	ACCT # 2010 NAPAGOLD FUE	SUPPLIES & SMALL TOOLS	002-1102-3136	16.55
BRAUNTEX MATERIALS, INC.	100840	ACCT # 1600 1700 FM 2700	FLEX BASE MATERIALS	002-1101-3143	22,938.60
BENNY BOYD LOCKHART, LLC	31365	ACCT # 5020 ACTUATOR	OPERATING SUPPLIES	002-1103-3135	242.00
SMITH SUPPLY CO.- LOCKHA	806734	T-POST 6'25 HVY STEEL 5CLP	OPERATING SUPPLIES	002-1101-3130	67.90
LULING CHEVROLET	101621	CUST # 1507 PANEL	OPERATING SUPPLIES	002-1103-3135	497.55
HANSON EQUIPMENT	271139	# CAL001 HOSE-FARMEX II 1	OPERATING SUPPLIES	002-1101-3130	37.16

Expense Approval Register

Packet: APPKT03083 - 5/13/19 A/P RUN

Vendor Name	Payable Number	Description (Item)	Account Name	Account Number	Amount
LOCKHART HARDWARE	28264 /1	CUST # 11239 SCREWS, NUT	OPERATING SUPPLIES	002-1101-3130	26.58
LOCKHART HARDWARE	28270 /1	CUST # 11239 MS170 1.9CI	OPERATING SUPPLIES	002-1101-3130	479.97
LOCKHART HARDWARE	28274 /1	CUST # 11239 ROLLER FRAM	OPERATING SUPPLIES	002-1101-3130	173.80
LARRY D. RIVERA	EMT-20851	5.00 FT X 6.00 FT PREMIUM	SIGNS	002-1101-3181	214.59
ASSOCIATED SUPPLY COMPA	PSO069185-1	ORDER # PSO069185 CUST #	SUPPLIES & SMALL TOOLS	002-1102-3136	143.04
LOCKHART HARDWARE	28291 /1	CUST # 11239 SANDPAPR AL	OPERATING SUPPLIES	002-1101-3130	9.18
CINTAS CORPORATION #86	4020224641	SOLD TO # 13232664 PAYER	UNIFORMS	002-1101-2140	216.70
CINTAS CORPORATION #86	4020224680	SOLD TO # 13228849 PAYER	UNIFORMS	002-1101-2140	345.62
CINTAS CORPORATION #86	4020224724	SOLD TO # 13232687 PAYER	UNIFORMS	002-1101-2140	139.36
CINTAS CORPORATION #86	4020224869	SOLD TO # 13228085 PAYER	UNIFORMS	002-1103-2140	76.69
DEWITT POTH & SON	569546-0	CUST # 12430 TRIMMER, CLS	OPERATING SUPPLIES	002-1101-3130	172.55
SMITH SUPPLY CO.- LOCKHA	807031	FLUOR ORANGE MARKING	OPERATING SUPPLIES	002-1101-3130	60.40
SMITH SUPPLY CO.- LOCKHA	807050	RATCHET WRENCH FLEXIBLE	OPERATING SUPPLIES	002-1101-3130	27.90
LOCKHART HARDWARE	28319 /1	CUST # 11239 MS170 1.9CI	OPERATING SUPPLIES	002-1101-3130	468.91
O'REILLY AUTOMOTIVE, INC.	0642-265789	CUST # 188092 LACQ THINN	SUPPLIES & SMALL TOOLS	002-1102-3136	22.65
LOCKHART HARDWARE	28345 /1	CUST # 11239 RYL EXT SAT L	OPERATING SUPPLIES	002-1101-3130	30.99
LOCKHART HARDWARE	28350 /1	CUST # 11239 16" .050" LAM	OPERATING SUPPLIES	002-1101-3130	34.96
SOUTHERN TIRE MART, LLC	4650008078	CUST # 142726 SPOT REPAIR	TIRES	002-1101-3190	225.00
SMITH SUPPLY CO.- LOCKHA	807540	MARKING PAINT RED-ORAN	OPERATING SUPPLIES	002-1101-3130	27.50
O'REILLY AUTOMOTIVE, INC.	0642-265925	CUST # 188092 BATTERY	SUPPLIES & SMALL TOOLS	002-1102-3136	356.74
O'REILLY AUTOMOTIVE, INC.	0642-266027	CUST # 188092 36# PSA SHE	SUPPLIES & SMALL TOOLS	002-1102-3136	4.62
CAPITOL AUTO PARTS	07MC7776	CUST # L10358 BENDIX BRAK	OPERATING SUPPLIES	002-1103-3135	424.05
DOBIE SUPPLY, LLC	22625	18" X 24" HIM PRINTED SIGN	SIGNS	002-1101-3181	673.00
HANSON EQUIPMENT	271256	# CAL001 EMBLEM W/STEEL	OPERATING SUPPLIES	002-1101-3130	529.70
LOCKHART HARDWARE	28368 /1	CUST # 11239 SCREWS, NUT	OPERATING SUPPLIES	002-1101-3130	51.03
LOCKHART HARDWARE	28371 /1	CUST # 11239 HEFTY BAG 30	OPERATING SUPPLIES	002-1101-3130	19.98
LOCKHART HARDWARE	28379 /1	CUST # 11239 SCREWS, NUT	OPERATING SUPPLIES	002-1101-3130	21.97
LOCKHART MOTOR CO.,INC.	T45482	CUST # 3810 CONTROL	OPERATING SUPPLIES	002-1103-3135	34.80
LOCKHART MOTOR CO.,INC.	T45488	CUST # 3810 SENSOR - EXHA	OPERATING SUPPLIES	002-1103-3135	516.09
SEAN MATTHEW MANN	099717	ACCT # 2010 32 PREMIUM B	SUPPLIES & SMALL TOOLS	002-1102-3136	47.88
LOCKHART HARDWARE	28399 /1	CUST # 11239 SILICONE I W	OPERATING SUPPLIES	002-1101-3130	21.97
CINTAS CORPORATION #86	4020645448	SOLD TO # 13228085 PAYER	UNIFORMS	002-1103-2140	76.69
CINTAS CORPORATION #86	4020645464	SOLD # 13232687 PAYER # 1	UNIFORMS	002-1101-2140	139.36
CINTAS CORPORATION #86	4020645465	SOLD TO # 13232664 PAYER	UNIFORMS	002-1101-2140	212.70
CINTAS CORPORATION #86	4020645476	SOLD TO # 13228849 PAYER	UNIFORMS	002-1101-2140	345.62
SOUTHERN TIRE MART, LLC	4650009733	V-STEK	TIRES	002-1101-3190	965.00
BENNY BOYD LOCKHART, LLC	55922	CUST # 10540 DODGE CHAR	CONTRACT LABOR	002-1103-4529	437.09
SMITH SUPPLY CO.- LOCKHA	807839	WASHER FLAT 1/4 EG	OPERATING SUPPLIES	002-1101-3130	43.08
SCHMIDT & SONS, INC	0446050-IN	CUST # 05-CALDCO FS SYNT	OPERATING SUPPLIES	002-1103-3135	1,029.37
SCHMIDT & SONS, INC	0446051-IN	CUST # 05-CALDCO PREMIU	LUBRICANTS	002-1101-3170	1,544.09
JOHN DEERE FINANCIAL	1904-028325	ACCT # 1-99 10 X 3/4 PHILLI	OPERATING SUPPLIES	002-1101-3130	28.50
HANSON EQUIPMENT	271297	# CAL001 FLAT TIRE REPAIR	TIRES	002-1101-3190	16.83
HANSON EQUIPMENT	271298	# CAL001 TIRE GAUGE-LON	TIRES	002-1101-3190	29.74
SCHMIDT & SONS, INC	4460518-IN	CUST # 05-CALDCO PREMIU	LUBRICANTS	002-1101-3170	1,513.81
SCHMIDT & SONS, INC	446051A-CM	CUST # 05-CALDCO PREMIU	LUBRICANTS	002-1101-3170	1,544.09
O'REILLY AUTOMOTIVE, INC.	0642-266413	CUST # 188092 36# PSA SHE	SUPPLIES & SMALL TOOLS	002-1102-3136	28.58
CAPITOL AUTO PARTS	07MC9064	CUST # L10358 AIR FILTER - P	OPERATING SUPPLIES	002-1103-3135	114.70
CAPITOL AUTO PARTS	07MC9088	CUST # L10358 AIR FILTER -	OPERATING SUPPLIES	002-1103-3135	18.05
SEAN MATTHEW MANN	099755	ACCT # 2010 GAS CAP	SUPPLIES & SMALL TOOLS	002-1102-3136	6.24
LOCKHART HARDWARE	28423/1	CUST # 11239 MARKING PAI	OPERATING SUPPLIES	002-1101-3130	58.90
LOCKHART HARDWARE	28424 /1	CUST # 11239 71 PM3 PICC	OPERATING SUPPLIES	002-1101-3130	45.98
SMITH SUPPLY CO.- LOCKHA	807989	POLY LEAF RAKE LPIS	OPERATING SUPPLIES	002-1101-3130	10.95
SCHMIDT & SONS, INC	0446149-IN	CUST # 05-CALDCO CHV DEL	LUBRICANTS	002-1101-3170	995.50
O'REILLY AUTOMOTIVE, INC.	0642-267041	CUST # 188092 CORE RETUR	SUPPLIES & SMALL TOOLS	002-1102-3136	-44.00
JOHN DEERE FINANCIAL	1904-030979	ACCT # 1-99 SPRAY PAINT 2X	OPERATING SUPPLIES	002-1101-3130	58.32
SMITH SUPPLY CO.-LULING	69066	FLUOR ORANGE MARKING S	OPERATING SUPPLIES	002-1101-3130	37.06
SMITH SUPPLY CO.-LULING	69079	MONSTER MAGGRIP 1230	OPERATING SUPPLIES	002-1101-3130	19.95
SMITH SUPPLY CO.- LOCKHA	808233	FLAT BLACK SPRAY	OPERATING SUPPLIES	002-1101-3130	34.80
HANSON EQUIPMENT	270842	# CAL001 340/18 TIRE REPAI	OPERATING SUPPLIES	002-1101-3130	267.21
CINTAS CORPORATION #86	4019388191	SOLD TO # 13232687 PAYER	UNIFORMS	002-1101-2140	139.36

Expense Approval Register

Packet: APPKT03083 - 5/13/19 A/P RUN

Vendor Name	Payable Number	Description (Item)	Account Name	Account Number	Amount
CINTAS CORPORATION #86	4019388196	SOLD TO # 13228849 PAYER	UNIFORMS	002-1101-2140	321.89
CINTAS CORPORATION #86	4019388205	SOLD TO: 13232664 PAYER #	UNIFORMS	002-1101-2140	212.70
CINTAS CORPORATION #86	4019388343	SOLD TO # 13228085 PAYER	UNIFORMS	002-1103-2140	68.70
SMITH SUPPLY CO.- LOCKHA	805384	HEX NUT FULL 5/16	OPERATING SUPPLIES	002-1101-3130	40.00
SEAN MATTHEW MANN	101019	CUST # 2010 DOOR HANDLE	SUPPLIES & SMALL TOOLS	002-1102-3136	95.99
E & R SUPPLY CO., INC	216219	ACCT # 23750 STR. F. SAE37	SUPPLIES & SMALL TOOLS	002-1102-3136	117.62
HOFMANN'S SUPPLY	838147	CUST # 01734 ACETYLENE S	RENTALS	002-1101-4610	103.84
FLEETPRIDE	24215581	ACCT # 83215 DRAG LINK F	SUPPLIES & SMALL TOOLS	002-1102-3136	670.42
HANSON EQUIPMENT	270874	# CAL001 HANDGUN / EXTE	OPERATING SUPPLIES	002-1101-3130	46.63
CAPITOL AUTO PARTS	07MC0727	CUST # L10358 ANCO 31-SE	OPERATING SUPPLIES	002-1103-3135	79.24
HANSON EQUIPMENT	270895	HOSE -FARMEX II 1/2" 3500P	OPERATING SUPPLIES	002-1101-3130	40.61
SMITH SUPPLY CO.- LOCKHA	805674	ACRH 15" MTL, CLVRT D1 16	CULVERT PIPE	002-1101-3116	811.80
SMITH SUPPLY CO.- LOCKHA	805741	BLACK NIPPLE STD 3/4 X 48	OPERATING SUPPLIES	002-1101-3130	38.85
O'REILLY AUTOMOTIVE, INC.	0642-263064	CUST # 188092 WIX - CABIN	SUPPLIES & SMALL TOOLS	002-1102-3136	25.42
BRAUNTEX MATERIALS, INC.	100679	ACCT # 1600 REEDVILLE	FLEX BASE MATERIALS	002-1101-3143	70,722.00
HANSON EQUIPMENT	270945	# CAL001 FLAT TIRE REPAIR	TIRES	002-1101-3190	19.34
HANSON EQUIPMENT	270974	# CAL001 PUMP FITTING KIT	OPERATING SUPPLIES	002-1101-3130	11.14
CINTAS CORPORATION #86	4008458887 CORRECTION	SOLD TO # 13232664 SHOUL	UNIFORMS	002-1101-2140	470.99
					119,421.36
Fund 002 - UNIT ROAD FUND Total:					119,421.36
Fund: 010 - GRANT FUND					
DAVID A MUSICK	41119	16 TAILS	MISCELLANEOUS--OTHER	010-1000-4850	80.00
LEANE BURT	41119	8 TAILS	MISCELLANEOUS--OTHER	010-1000-4850	40.00
STEPHEN BECK	41119	21 TAILS	MISCELLANEOUS--OTHER	010-1000-4850	105.00
VALENTINE RAMIREZ	41119	183 TAILS	MISCELLANEOUS--OTHER	010-1000-4850	915.00
HERSHELL WARNER	41119	8 TAILS	MISCELLANEOUS--OTHER	010-1000-4850	40.00
Joe Smith	41119	8 TAILS	MISCELLANEOUS--OTHER	010-1000-4850	40.00
JAMES F. STONE	41119	78 HOG TAILS	MISCELLANEOUS--OTHER	010-1000-4850	390.00
MICKEY VAN DYKE	41119	12 HOG TAILS	MISCELLANEOUS--OTHER	010-1000-4850	60.00
MARTIN RAY MARTINEZ	41119	6 HOG TAILS	MISCELLANEOUS--OTHER	010-1000-4850	30.00
RUEBEN NIEMANN	41119	37 HOG TAILS	MISCELLANEOUS--OTHER	010-1000-4850	185.00
EMIL NIEMANN	41119	36 HOG TAILS	MISCELLANEOUS--OTHER	010-1000-4850	180.00
JAMES HARLON REED	41119	8 TAILS	MISCELLANEOUS--OTHER	010-1000-4850	40.00
WILLIAM C. KOCTAR	41119	15 HOG TAILS	MISCELLANEOUS--OTHER	010-1000-4850	75.00
BENNY PERRIRAZ	41119	76 HOG TAILS	MISCELLANEOUS--OTHER	010-1000-4850	380.00
DALTON GENE AYERS	41119	22 HOG TAILS	MISCELLANEOUS--OTHER	010-1000-4850	110.00
H2O PARTNERS, INC	113346	CONDUCT HAZARD RESEARC	PROFESSIONAL SERVICES-H	010-6650-4110	9,450.00
					12,120.00
Fund 010 - GRANT FUND Total:					12,120.00
Fund: 013 - CAPITAL PROJECTS FUND					
RDO EQUIPMENT CO.	E31832	ACCT # 7269004 MOTOR GR	MACHINERY AND EQUIPME	013-1101-5310	643,731.00
ASSOCIATED SUPPLY COMPA	013-03	CUST # BP0068193 SINGLE	MACHINERY AND EQUIPME	013-1101-5310	196,095.24
					839,826.24
Fund 013 - CAPITAL PROJECTS FUND Total:					839,826.24
Grand Total:					1,178,971.37

Fund Summary

Fund	Expense Amount
001 - GENERAL FUND	207,603.77
002 - UNIT ROAD FUND	119,421.36
010 - GRANT FUND	12,120.00
013 - CAPITAL PROJECTS FUND	839,826.24
Grand Total:	1,178,971.37

Account Summary

Account Number	Account Name	Expense Amount
001-1260	DUE FROM C C A D	122.52
001-1370	POSTAGE INVENTORY	1,612.83
001-2120-5310	MACHINERY AND EQUIP	425.69
001-2140-3110	OFFICE SUPPLIES	64.00
001-2140-4110	PROFESSIONAL SERVICE	2,176.55
001-2140-4260	TRANSPORTATION	236.64
001-2150-3110	OFFICE SUPPLIES	829.63
001-2150-4810	TRAINING	660.20
001-2730	DUE TO State-Failure to	2,850.00
001-3200-3050	DUES & SUBSCRIPTIONS	1,730.00
001-3200-3110	OFFICE SUPPLIES	632.63
001-3200-4260	TRANSPORTATION	242.10
001-3200-4315	PUBLICATIONS	100.00
001-3200-4810	TRAINING	782.25
001-3220-3110	OFFICE SUPPLIES	1,362.20
001-3220-4810	TRAINING	275.00
001-3230-4080	ADULT - ATTY LITIGATIO	667.46
001-3230-4150	ADULT - EXPERT WITNES	750.00
001-3230-4160	ADULT - INDIGENT ATTO	30,769.00
001-3230-4170	TRIAL EXPENSE	160.00
001-3230-4820	JUROR EXPENSE	53.64
001-3240-4080	ADULT - ATTY LITIGATIO	46.91
001-3240-4150	ADULT - EXPERT WITNES	750.00
001-3240-4160	ADULT - INDIGENT ATTO	7,950.00
001-3240-4180	JUVENILE - INDIGENT AT	300.00
001-3251-3110	OFFICE SUPPLIES	193.60
001-3251-3120	POSTAGE	20.84
001-3252-2070	EMPLOYEE BONDING	71.00
001-3252-3110	OFFICE SUPPLIES	315.57
001-3252-4810	TRAINING	250.11
001-3253-3110	OFFICE SUPPLIES	222.29
001-3253-4810	TRAINING	60.00
001-3254-3110	OFFICE SUPPLIES	361.07
001-4300-3130	OPERATING SUPPLIES	528.09
001-4300-4110	PROFESSIONAL SERVICE	1,041.90
001-4300-4260	TRANSPORTATION	10,729.11
001-4300-4420	TELEPHONE	37.99
001-4300-4810	TRAINING	115.00
001-4310-3100	FOOD SUPPLIES	23,320.31
001-4310-3130	OPERATING SUPPLIES	6,529.25
001-4310-4110	PROFESSIONAL SERVICE	46,573.59
001-4310-4135	EMPLOYEE PHYSICALS	590.00
001-4310-4260	TRANSPORTATION	1,302.60
001-4310-4510	REPAIRS & MAINTENAN	6,219.91
001-4310-4810	TRAINING	686.00
001-4321-4260	TRANSPORTATION	645.03
001-4321-4810	TRAINING	17.99
001-4322-4260	TRANSPORTATION	698.11
001-4323-4260	TRANSPORTATION	428.74
001-4324-4260	TRANSPORTATION	274.08
001-4324-5310	MACHINERY AND EQUIP	241.50

Account Summary

Account Number	Account Name	Expense Amount
001-4325-4610	RENTALS	287.50
001-6510-3110	OFFICE SUPPLIES	3,066.00
001-6510-4123	AUTOPSY	300.00
001-6510-4420	Telephone	4,387.99
001-6510-4425	FAX & INTERNET	13,687.72
001-6510-4610	RENTALS	5,992.08
001-6510-4850	MISCELLANEOUS	125.11
001-6520-3130	OPERATING SUPPLIES	261.17
001-6520-3140	UNIFORMS	502.37
001-6520-3500	JP3 SIMON BUILDING-M	117.07
001-6520-3510	LULING ANNEX	551.13
001-6520-3530	MARKET ST. ANNEX-LOC	37.98
001-6520-3540	L.W.SCOTT ANNEX-LOCK	298.34
001-6520-3550	JUDICIAL CENTER-LOCK	3,200.85
001-6520-3560	JP1/DRC BUILDING-LOC	16.00
001-6520-3580	JUVENILE DETENTION CT	12.00
001-6520-3600	BUILDING MAINTENANC	1,065.44
001-6520-3630	UNIT ROAD MAINTENAN	261.71
001-6520-4260	TRANSPORTATION	557.18
001-6520-4440	GROUNDS UPKEEP	14.35
001-6520-5120	CALDWELL CO. COURTH	1,296.65
001-6550-3110	OFFICE SUPPLIES	86.25
001-6560-4260	TRANSPORTATION	50.00
001-6570-3110	OFFICE SUPPLIES	20.92
001-6570-4810	TRAINING	346.46
001-6580-4810	TRAINING	189.00
001-6590-4810	TRAINING	275.00
001-6600-4110	Professional Services	1,850.00
001-6610-4510	REPAIRS & MAINTENAN	173.19
001-6630-4260	TRANSPORTATION	177.83
001-6630-4810	TRAINING	199.00
001-6640-3140	UNIFORMS	195.92
001-6640-3151	DISPOSAL FEES	296.00
001-6640-4260	TRANSPORTATION	256.52
001-6650-3110	OFFICE SUPPLIES	221.14
001-6650-4260	TRANSPORTATION	693.69
001-6650-4810	TRAINING	1,796.24
001-7610-3110	OFFICE SUPPLIES	115.78
001-7610-4260	TRANSPORTATION	142.32
001-7620-4312	SANITY HEARINGS	458.00
001-7620-4320	INDIGENT FUNERAL	1,190.00
001-8700-3110	OFFICE SUPPLIES	204.97
001-8700-4251	MILEAGE REIMB- ADH D	124.12
001-8700-4260	TRANSPORTATION	5,479.85
002-1101-2140	UNIFORMS	3,987.17
002-1101-3116	CULVERT PIPE	811.80
002-1101-3130	OPERATING SUPPLIES	4,000.85
002-1101-3143	FLEX BASE MATERIALS	93,660.60
002-1101-3163	FUEL	5,528.24
002-1101-3170	LUBRICANTS	2,509.31
002-1101-3181	SIGNS	887.59
002-1101-3190	TIRES	1,255.91
002-1101-4610	RENTALS	103.84
002-1102-3136	SUPPLIES & SMALL TOO	2,532.16
002-1103-2140	UNIFORMS	298.77
002-1103-3135	OPERATING SUPPLIES	3,408.03
002-1103-4529	CONTRACT LABOR	437.09
010-1000-4850	MISCELLANEOUS--OTHE	2,670.00

Account Summary

Account Number	Account Name	Expense Amount
010-6650-4110	PROFESSIONAL SERVICE	9,450.00
013-1101-5310	MACHINERY AND EQUIP	839,826.24
	Grand Total:	1,178,971.37

Project Account Summary

Project Account Key	Expense Amount
None	1,178,971.37
	Grand Total:
	1,178,971.37

2. Approve County Purchase Orders in the amount of \$17,300.53; Backup: 4

Caldwell County Agenda Item Request Form

To: All Elected Officials and Department Heads – Hand deliver or scan & email to hoppy.haden@co.caldwell.tx.us and ezzy.chan@co.caldwell.tx.us . Deadline is 5:00 pm Tuesday before the Regular meetings, however, please submit this completed form ASAP. "Anything missing will cause the Agenda Item to be held over to the next Regular meeting," according to our Rules & Procedures.

AGENDA DATE: 5/13/2019

Type of Agenda Item

- Consent Discussion/Action Executive Session Workshop
 Public Hearing

What will be discussed? What is the proposed motion?

to approve County Purchase Orders in the amount of \$17,300.53

1. Costs:

Actual Cost or Estimated Cost \$ 17,300.53

Is this cost included in the County Budget? _____

Is a Budget Amendment being proposed? _____

2. Agenda Speakers:

Name	Representing	Title
------	--------------	-------

(1) _____

(2) _____

(3) _____

3. Backup Materials: None To Be Distributed 6 total # of backup pages
(including this page)

4. 
Signature of Court Member

5/7/2019
Date



Caldwell County, TX

Payment Register

APPKT03084 - 5/13/19 PURCHASE ORDERS

01 - Vendor Set 01

Bank: AP BNK - Pooled Cash - Operation

Vendor Number	Vendor Name					Total Vendor Amount
<u>AUSPEE</u>	AUSTIN PEEL AND SON FUNERAL HOME					650.00
Payment Type	Payment Number				Payment Date	Payment Amount
Check					05/06/2019	650.00
Payable Number	Description	Payable Date	Due Date	Discount Amount	Payable Amount	
<u>AUSPEE</u>	WINNIE E.M. JUKES-TATE / DOD: 12/17/18	05/03/2019	05/03/2019	0.00	650.00	
Vendor Number	Vendor Name					Total Vendor Amount
<u>CARTS</u>	CAPITAL AREA RURAL TRANSPORTATION SYSTEM					3,000.00
Payment Type	Payment Number				Payment Date	Payment Amount
Check					05/06/2019	3,000.00
Payable Number	Description	Payable Date	Due Date	Discount Amount	Payable Amount	
<u>42419</u>	DONATION APPROVED 4/22/19	04/26/2019	04/26/2019	0.00	3,000.00	
Vendor Number	Vendor Name					Total Vendor Amount
<u>GOOAUT</u>	GOODYEAR AUTO SERVICE CENTER					3,878.04
Payment Type	Payment Number				Payment Date	Payment Amount
Check					05/06/2019	3,878.04
Payable Number	Description	Payable Date	Due Date	Discount Amount	Payable Amount	
<u>229870</u>	ACCT # 473509272 245/55R18 103V EAGLE RS A VSB T	04/15/2019	05/13/2019	0.00	3,878.04	
Vendor Number	Vendor Name					Total Vendor Amount
<u>PRISOL</u>	PRINTING SOLUTIONS					770.94
Payment Type	Payment Number				Payment Date	Payment Amount
Check					05/06/2019	770.94
Payable Number	Description	Payable Date	Due Date	Discount Amount	Payable Amount	
<u>32019</u>	CONST # 2 BOOK 3 PART - 25 INVOICES PER BOOK	03/20/2019	05/13/2019	0.00	770.94	
Vendor Number	Vendor Name					Total Vendor Amount
<u>SHIGOV</u>	SHI GOVERNMENT SOLUTIONS, INC.					1,889.40
Payment Type	Payment Number				Payment Date	Payment Amount
Check					05/06/2019	1,889.40
Payable Number	Description	Payable Date	Due Date	Discount Amount	Payable Amount	
<u>GB00321877</u>	ACROBAT PROFESSIONAL 2017 - LICENSE - NEW	04/15/2019	05/13/2019	0.00	1,889.40	
Vendor Number	Vendor Name					Total Vendor Amount
<u>SPEPUB</u>	SPECIALIZED PUBLIC FINANCE INC.					1,500.00
Payment Type	Payment Number				Payment Date	Payment Amount
Check					05/06/2019	1,500.00
Payable Number	Description	Payable Date	Due Date	Discount Amount	Payable Amount	
<u>150 FY 2018</u>	PREPARATION AND FILING OF FY 2018 ANNUAL DISCLOS	04/15/2019	05/13/2019	0.00	1,500.00	
Vendor Number	Vendor Name					Total Vendor Amount
<u>TYLTEC</u>	TYLER TECHNOLOGIES, INC.					5,612.15
Payment Type	Payment Number				Payment Date	Payment Amount
Check					05/06/2019	5,612.15
Payable Number	Description	Payable Date	Due Date	Discount Amount	Payable Amount	
<u>025-257512</u>	CUST # 47804 ONSITE TRAINING JACQUELINE JONES	04/24/2019	05/13/2019	0.00	5,612.15	

Payment Summary

Bank Code	Type	Payable Count	Payment Count	Discount	Payment
AP BNK	Check	7	7	0.00	17,300.53
Packet Totals:		<u>7</u>	<u>7</u>	<u>0.00</u>	<u>17,300.53</u>

Cash Fund Summary

Fund	Name	Amount
999	POOLED CASH	-17,300.53
	Packet Totals:	<u>-17,300.53</u>

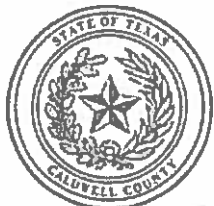

Caldwell County, TX

Expense Approval Register

cket: APPKT03084 - 5/13/19 PURCHASE ORDERS

Vendor Name	Payable Number	Description (Item)	Account Name	Account Number	Amount
Fund: 001 - GENERAL FUND					
Department : 2130 - COUNTY AUDITOR					
SHI GOVERNMENT SOLUTIO	GB00321877	Adobe Acrobat Pro 2017	OFFICE SUPPLIES	001-2130-3110	755.76
Department 2130 - COUNTY AUDITOR Total:					755.76
Department : 4322 - CONSTABLES - PCT 2					
PRINTING SOLUTIONS	32019	Book - 3 Part - 25 invoices pe	OFFICE SUPPLIES	001-4322-3110	770.94
Department 4322 - CONSTABLES - PCT 2 Total:					770.94
Department : 6510 - NON-DEPARTMENTAL					
SPECIALIZED PUBLIC FINANC	150 FY 2018	Prep & Filing of HB 1378 Disc	PROFESSIONAL SERVICES	001-6510-4110	500.00
SPECIALIZED PUBLIC FINANC	150 FY 2018	Prep & Filing FY 2018 Annual	PROFESSIONAL SERVICES	001-6510-4110	1,000.00
TYLER TECHNOLOGIES, INC.	025-257512	Parking	PROFESSIONAL SERVICES	001-6510-4110	5.50
TYLER TECHNOLOGIES, INC.	025-257512	Car Rental - Fuel	PROFESSIONAL SERVICES	001-6510-4110	46.63
TYLER TECHNOLOGIES, INC.	025-257512	April 17 On Site Training	PROFESSIONAL SERVICES	001-6510-4110	1,000.00
TYLER TECHNOLOGIES, INC.	025-257512	April 16 On Site Training	PROFESSIONAL SERVICES	001-6510-4110	1,000.00
TYLER TECHNOLOGIES, INC.	025-257512	Fuel	PROFESSIONAL SERVICES	001-6510-4110	55.22
TYLER TECHNOLOGIES, INC.	025-257512	Car Rental	PROFESSIONAL SERVICES	001-6510-4110	232.45
TYLER TECHNOLOGIES, INC.	025-257512	April 18 On Site Training	PROFESSIONAL SERVICES	001-6510-4110	1,000.00
TYLER TECHNOLOGIES, INC.	025-257512	Hotel Lodging	PROFESSIONAL SERVICES	001-6510-4110	475.64
TYLER TECHNOLOGIES, INC.	025-257512	Airfare	PROFESSIONAL SERVICES	001-6510-4110	488.49
TYLER TECHNOLOGIES, INC.	025-257512	Per Diem Rates	PROFESSIONAL SERVICES	001-6510-4110	253.00
TYLER TECHNOLOGIES, INC.	025-257512	Milage	PROFESSIONAL SERVICES	001-6510-4110	55.22
TYLER TECHNOLOGIES, INC.	025-257512	April 15 On Site Training	PROFESSIONAL SERVICES	001-6510-4110	1,000.00
CAPITAL AREA RURAL TRANS	42419	CARTS - Donation	DONATIONS	001-6510-3200	3,000.00
Department 6510 - NON-DEPARTMENTAL Total:					10,112.15
Department : 6560 - COMMISSIONERS COURT					
SHI GOVERNMENT SOLUTIO	GB00321877	Adobe Acrobat Pro 2017	OFFICE SUPPLIES	001-6560-3110	755.76
Department 6560 - COMMISSIONERS COURT Total:					755.76
Department : 6590 - PURCHASING					
SHI GOVERNMENT SOLUTIO	GB00321877	Adobe Acrobat Pro 2017	OFFICE SUPPLIES	001-6590-3110	377.88
Department 6590 - PURCHASING Total:					377.88
Department : 7620 - COUNTY WELFARE					
AUSTIN PEEL AND SON FUNE	AUSPEE	Direct Burial	INDIGENT FUNERAL	001-7620-4320	2,040.00
AUSTIN PEEL AND SON FUNE	AUSPEE	Direct Burial - Discount	INDIGENT FUNERAL	001-7620-4320	-1,390.00
Department 7620 - COUNTY WELFARE Total:					650.00
Fund 001 - GENERAL FUND Total:					13,422.49
Fund: 002 - UNIT ROAD FUND					
Department : 1103 - FLEET MAINTENANCE					
GOODYEAR AUTO SERVICE C	229870	245/55R18 103V Eagle RS A	TIRES	002-1103-3190	2,842.20
GOODYEAR AUTO SERVICE C	229870	P225/50R18 99W SL EAG RS-	TIRES	002-1103-3190	1,035.84
Department 1103 - FLEET MAINTENANCE Total:					3,878.04
Fund 002 - UNIT ROAD FUND Total:					3,878.04
Grand Total:					17,300.53

Fund Summary

Fund	Expense Amount
001 - GENERAL FUND	13,422.49
002 - UNIT ROAD FUND	3,878.04
Grand Total:	17,300.53

Account Summary

Account Number	Account Name	Expense Amount
001-2130-3110	OFFICE SUPPLIES	755.76
001-4322-3110	OFFICE SUPPLIES	770.94
001-6510-3200	DONATIONS	3,000.00
001-6510-4110	PROFESSIONAL SERVICE	7,112.15
001-6560-3110	OFFICE SUPPLIES	755.76
001-6590-3110	OFFICE SUPPLIES	377.88
001-7620-4320	INDIGENT FUNERAL	650.00
002-1103-3190	TIRES	3,878.04
Grand Total:		17,300.53

Project Account Summary

Project Account Key	Expense Amount
None	17,300.53
Grand Total:	17,300.53

3. Ratify re-occurring County payments in the amount of:

A. \$286,087.79 (Payroll for 03/31/2019 – 04/13/2019); Backup: 21

Caldwell County Agenda Item Request Form

To: All Elected Officials and Department Heads – Hand deliver or scan & email to hoppy.haden@co.caldwell.tx.us and ezzy.chan@co.caldwell.tx.us . Deadline is 5:00 pm Tuesday before the Regular meetings, however, please submit this completed form ASAP. "Anything missing will cause the Agenda Item to be held over to the next Regular meeting," according to our Rules & Procedures.

AGENDA DATE: 5/13/2019

Type of Agenda Item

- Consent Discussion/Action Executive Session Workshop
- Public Hearing

What will be discussed? What is the proposed motion?
to approve 3/31/19-4/13/19 Payroll in the amount of \$286,087.79

1. Costs:

Actual Cost or Estimated Cost \$ 286,087.79

Is this cost included in the County Budget? yes

Is a Budget Amendment being proposed? no

2. Agenda Speakers:

Name	Representing	Title
(1) _____	_____	_____
(2) _____	_____	_____
(3) _____	_____	_____

3. Backup Materials: None To Be Distributed 21 total # of backup pages
(including this page)

4. 
Signature of Court Member

5/7/2019
Date



Caldwell County, TX

Detail Register

Department Summary

Packet: PYPKT01284 - 033119 thru 041319 PP with Pay Date 041819
 Payroll Set: 01 - Payroll Set 01

Pay Period: 03/31/2019 - 04/13/2019

Department: 1000 - Courthouse Security

Total Direct Deposits: 8,233.60
 Total Check Amounts: 1,173.93

EARNINGS

Pay Code	Units	Pay Amount
165 Stipend w/RET	0.00	16.15
BEREAVEMENT	24.00	437.44
Hourly	575.00	10,814.94
OT	7.00	191.38
S	25.00	455.66
Uniform	0.00	200.00
Vacation	16.00	291.62
Total:	647.00	12,407.19

TAXES

Code	Subject To	Employee	Employer
Federal W/H	11,409.90	857.19	0.00
MC	12,030.28	174.44	174.44
SS	12,030.28	745.90	745.90
Unemployment	12,269.90	0.00	0.00
Total:		1,777.53	920.34

DEDUCTIONS

Code	Subject To	Employee	Employer
400	12,407.19	620.38	537.24
550	0.00	137.29	0.00
580	0.00	6.12	0.00
590	0.00	158.75	1,284.84
595	0.00	8.60	0.00
615	0.00	72.27	0.00
620	0.00	218.72	0.00
Total:		1,222.13	1,822.08

RECAP 1000 - Courthouse Security

Earnings:	12,407.19	Benefits:	0.00	Deductions:	1,222.13	Taxes:	1,777.53	Net Pay:	9,407.53
-----------	-----------	-----------	------	-------------	----------	--------	----------	----------	----------

Department: 1101 - Unit Road

Total Direct Deposits: 23,631.97
 Total Check Amounts: 2,096.09

EARNINGS

Pay Code	Units	Pay Amount
165 Stipend w/RET	0.00	66.92
FLOAT	2.00	35.29
Hourly	1,751.50	30,607.82
OT	14.00	401.28
S	26.00	450.52
SAL	1.00	1,853.15
Vacation	60.50	1,042.06
Total:	1,855.00	34,457.04

TAXES

Code	Subject To	Employee	Employer
Federal W/H	31,358.58	2,555.38	0.00
MC	33,081.42	479.69	479.69
SS	33,081.42	2,051.06	2,051.06
Unemployment	34,303.96	0.00	0.00
Total:		5,086.13	2,530.75

DEDUCTIONS

Code	Subject To	Employee	Employer
400	34,457.04	1,722.84	1,491.99
530	0.00	0.00	0.00
550	0.00	153.08	0.00
551	0.00	68.00	0.00
580	0.00	15.30	0.00
590	0.00	983.02	7,044.12
595	0.00	19.34	0.00
610	0.00	0.00	0.00
615	0.00	152.18	0.00
Bankruptcy	0.00	529.09	0.00
Total:		3,642.85	8,536.11

RECAP 1101 - Unit Road

Earnings:	34,457.04	Benefits:	0.00	Deductions:	3,642.85	Taxes:	5,086.13	Net Pay:	25,728.06
-----------	-----------	-----------	------	-------------	----------	--------	----------	----------	-----------

Department: 1102 - Vehicle Maintenance

Total Direct Deposits: 980.55
 Total Check Amounts: 2,391.74

EARNINGS

Pay Code	Units	Pay Amount
Hourly	235.80	4,221.69
Vacation	4.20	73.32
Total:	240.00	4,295.01

TAXES

Code	Subject To	Employee	Employer
Federal W/H	4,031.14	332.51	0.00
MC	4,245.89	61.57	61.57
SS	4,245.89	263.24	263.24
Unemployment	4,282.04	0.00	0.00
Total:		657.32	324.81

DEDUCTIONS

Code	Subject To	Employee	Employer
400	4,295.01	214.75	185.97
550	0.00	12.97	0.00
551	0.00	20.00	0.00
580	0.00	1.53	0.00
590	0.00	0.00	952.38
615	0.00	16.15	0.00
Total:		265.40	1,138.35

RECAP 1102 - Vehicle Maintenance

Earnings:	4,295.01	Benefits:	0.00	Deductions:	265.40	Taxes:	657.32	Net Pay:	3,372.29
-----------	----------	-----------	------	-------------	--------	--------	--------	----------	----------

Department: 1103 - Fleet Maintenance

Total Direct Deposits: 1,251.18
 Total Check Amounts: 1,157.89

EARNINGS

Pay Code	Units	Pay Amount
Hourly	160.00	2,982.82
Total:	160.00	2,982.82

TAXES

Code	Subject To	Employee	Employer
Federal W/H	2,817.48	179.94	0.00
MC	2,966.62	43.01	43.01
SS	2,966.62	183.93	183.93
Unemployment	2,982.82	0.00	0.00
Total:	406.88	226.94	

DEDUCTIONS

Code	Subject To	Employee	Employer
400	2,982.82	149.14	129.16
580	0.00	1.53	0.00
590	0.00	0.00	634.92
615	0.00	16.20	0.00
Total:	166.87	764.08	

RECAP 1103 - Fleet Maintenance

Earnings:	2,982.82	Benefits:	0.00	Deductions:	166.87	Taxes:	406.88	Net Pay:	2,409.07
-----------	----------	-----------	------	-------------	--------	--------	--------	----------	----------

Department: 2120 - County Treasurer

Total Direct Deposits: 2,638.18
 Total Check Amounts: 0.00

EARNINGS

Pay Code	Units	Pay Amount
Hourly	80.00	1,543.42
SAL	1.00	1,848.25
Total:	81.00	3,391.67

TAXES

Code	Subject To	Employee	Employer
Federal W/H	3,102.93	209.82	0.00
MC	3,312.51	48.03	48.03
SS	3,312.51	205.37	205.37
Unemployment	3,391.67	0.00	0.00
Total:	463.22	253.40	

DEDUCTIONS

Code	Subject To	Employee	Employer
400	3,391.67	169.58	146.86
520	0.00	40.00	0.00
551	0.00	44.00	0.00
580	0.00	1.53	0.00
590	0.00	0.00	634.92
595	0.00	2.86	0.00
615	0.00	32.30	0.00
Total:	290.27	781.78	

RECAP 2120 - County Treasurer

Earnings:	3,391.67	Benefits:	0.00	Deductions:	290.27	Taxes:	463.22	Net Pay:	2,638.18
-----------	----------	-----------	------	-------------	--------	--------	--------	----------	----------

Department: 2130 - County Auditor

Total Direct Deposits: 5,580.99
 Total Check Amounts: 0.00

EARNINGS

Pay Code	Units	Pay Amount
FLOAT	14.00	297.68
Hourly	201.00	4,156.60
S	12.00	314.75
SAL	-3.00	2,923.07
Vacation	17.00	321.28
Total:	241.00	8,013.38

TAXES

Code	Subject To	Employee	Employer
Federal W/H	6,979.70	798.79	0.00
MC	7,580.37	109.92	109.92
SS	7,580.37	469.98	469.98
Unemployment	7,982.48	0.00	0.00
Total:	1,378.69	1,378.69	579.90

DEDUCTIONS

Code	Subject To	Employee	Employer
400	8,013.38	400.67	346.97
520	0.00	200.00	0.00
550	0.00	30.90	0.00
551	0.00	192.00	0.00
580	0.00	3.06	0.00
590	0.00	158.75	967.38
595	0.00	2.86	0.00
610	0.00	16.96	0.00
615	0.00	48.50	0.00
Total:	1,053.70	1,314.35	

RECAP 2130 - County Auditor

Earnings: 8,013.38 Benefits: 0.00 Deductions: 1,053.70 Taxes: 1,378.69 Net Pay: 5,580.99

Department: 2140 - Tax Assessor-Collector

Total Direct Deposits: 6,197.69
 Total Check Amounts: 0.00

EARNINGS

Pay Code	Units	Pay Amount
Hourly	367.25	5,920.84
S	23.00	358.77
SAL	1.00	1,829.82
Vacation	9.75	173.45
Total:	401.00	8,282.88

TAXES

Code	Subject To	Employee	Employer
Federal W/H	7,483.20	666.83	0.00
MC	8,027.33	116.40	116.40
SS	8,027.33	497.69	497.69
Unemployment	6,425.82	0.00	0.00
Total:	1,280.92	1,280.92	614.09

DEDUCTIONS

Code	Subject To	Employee	Employer
400	8,282.88	414.13	358.63
520	0.00	130.00	0.00
550	0.00	27.24	0.00
551	0.00	34.00	0.00
580	0.00	4.59	0.00
590	0.00	158.75	1,919.76
595	0.00	20.06	0.00
615	0.00	15.50	0.00
Total:	804.27	2,278.39	

RECAP 2140 - Tax Assessor-Collector

Earnings: 8,282.88 Benefits: 0.00 Deductions: 804.27 Taxes: 1,280.92 Net Pay: 6,197.69

Department: 2150 - County Clerk

Total Direct Deposits: 9,374.79
 Total Check Amounts: 0.00

EARNINGS

Pay Code	Units	Pay Amount
Hourly	627.75	9,999.84
S	12.25	198.10
SAL	1.00	1,868.45
Total:	641.00	12,066.39

TAXES

Code	Subject To	Employee	Employer
Federal W/H	11,062.41	710.30	0.00
MC	11,725.72	170.03	170.03
SS	11,725.72	727.00	727.00
Unemployment	11,974.33	0.00	0.00
Total:	1,607.33	897.03	

DEDUCTIONS

Code	Subject To	Employee	Employer
400	12,066.39	603.31	522.48
520	0.00	60.00	0.00
540	0.00	41.05	0.00
550	0.00	92.06	0.00
551	0.00	159.60	0.00
580	0.00	12.24	0.00
590	0.00	0.00	2,539.68
595	0.00	8.58	0.00
610	0.00	27.00	0.00
615	0.00	80.43	0.00
Total:	1,084.27	3,062.16	

RECAP 2150 - County Clerk

Earnings: 12,066.39 Benefits: 0.00 Deductions: 1,084.27 Taxes: 1,607.33 Net Pay: 9,374.79

Department: 3000 - County Clerk

Total Direct Deposits: 948.01
 Total Check Amounts: 0.00

EARNINGS

Pay Code	Units	Pay Amount
Hourly	78.50	1,274.96
S	1.50	24.36
Total:	80.00	1,299.32

TAXES

Code	Subject To	Employee	Employer
Federal W/H	1,033.58	0.00	0.00
MC	1,098.55	15.93	15.93
SS	1,098.55	68.11	68.11
Unemployment	1,299.32	0.00	0.00
Total:	84.04	84.04	

DEDUCTIONS

Code	Subject To	Employee	Employer
400	1,299.32	64.97	56.26
551	0.00	20.00	0.00
580	0.00	1.53	0.00
590	0.00	158.75	332.46
615	0.00	22.02	0.00
Total:	267.27	388.72	

RECAP 3000 - County Clerk

Earnings: 1,299.32 Benefits: 0.00 Deductions: 267.27 Taxes: 84.04 Net Pay: 948.01

Department: 3200 - District Attorney

Total Direct Deposits: 20,473.51
 Total Check Amounts: 146.60

EARNINGS

Pay Code	Units	Pay Amount
165 Stipend w/RET	0.00	16.15
DA Supplement	0.00	151.67
Hourly	589.50	11,278.87
Longevity w/RET	0.00	204.62
S	108.00	3,191.61
SAL	-117.00	11,410.19
Vacation	65.50	1,927.21
Total:	646.00	28,180.32

TAXES

Code	Subject To	Employee	Employer
Federal W/H	25,497.98	2,802.66	0.00
MC	26,966.98	391.02	391.02
SS	26,966.98	1,671.95	1,671.95
Unemployment	27,885.31	0.00	0.00
Total:		4,865.63	2,062.97

DEDUCTIONS

Code	Subject To	Employee	Employer
400	28,180.32	1,409.00	1,220.21
520	0.00	60.00	0.00
550	0.00	127.19	0.00
551	0.00	416.00	0.00
552	0.00	100.00	0.00
580	0.00	12.24	0.00
590	0.00	476.25	4,171.98
595	0.00	8.58	0.00
615	0.00	85.32	0.00
Total:		2,694.58	5,392.19

RECAP 3200 - District Attorney

Earnings: 28,180.32 Benefits: 0.00 Deductions: 2,694.58 Taxes: 4,865.63 Net Pay: 20,620.11

Department: 3220 - District Clerk

Total Direct Deposits: 8,178.68
 Total Check Amounts: 0.00

EARNINGS

Pay Code	Units	Pay Amount
FLOAT	8.00	115.39
Hourly	516.00	8,409.83
S	28.00	440.72
SAL	1.00	1,874.15
Vacation	8.00	134.77
Total:	561.00	10,974.86

TAXES

Code	Subject To	Employee	Employer
Federal W/H	9,625.79	658.05	0.00
MC	10,274.53	148.97	148.97
SS	10,274.53	637.03	637.03
Unemployment	9,058.73	0.00	0.00
Total:		1,444.05	786.00

DEDUCTIONS

Code	Subject To	Employee	Employer
400	10,974.86	548.74	475.22
520	0.00	100.00	0.00
550	0.00	41.98	0.00
551	0.00	36.76	0.00
580	0.00	3.06	0.00
590	0.00	491.51	2,252.22
595	0.00	11.19	0.00
615	0.00	118.89	0.00
Total:		1,352.13	2,727.44

RECAP 3220 - District Clerk

Earnings: 10,974.86 Benefits: 0.00 Deductions: 1,352.13 Taxes: 1,444.05 Net Pay: 8,178.68

Department: 3230 - District Judge

Total Direct Deposits: 4,574.80
 Total Check Amounts: 0.00

EARNINGS

Pay Code	Units	Pay Amount
FLOAT	8.00	318.83
Hourly	68.00	1,180.17
S	13.50	448.04
SAL	-11.50	4,154.90
Vacation	8.00	138.84
Total:	86.00	6,240.78

TAXES

Code	Subject To	Employee	Employer
Federal W/H	5,348.95	331.90	0.00
MC	5,760.99	83.53	83.53
SS	5,760.99	357.19	357.19
Unemployment	6,194.62	0.00	0.00
Total:	772.62	772.62	440.72

DEDUCTIONS

Code	Subject To	Employee	Employer
400	6,240.78	312.04	270.24
520	0.00	100.00	0.00
551	0.00	80.64	0.00
580	0.00	1.53	0.00
590	0.00	317.50	664.92
615	0.00	81.65	0.00
Total:	893.36	893.36	935.16

RECAP 3230 - District Judge

Earnings: 6,240.78 Benefits: 0.00 Deductions: 893.36 Taxes: 772.62 Net Pay: 4,574.80

Department: 3240 - County Court Law

Total Direct Deposits: 6,155.06
 Total Check Amounts: 0.00

EARNINGS

Pay Code	Units	Pay Amount
Jud Stip	0.00	3,230.77
SAL	2.00	5,506.98
Total:	2.00	8,737.75

TAXES

Code	Subject To	Employee	Employer
Federal W/H	8,018.51	1,197.48	0.00
MC	8,705.39	126.23	126.23
SS	8,705.39	539.74	539.74
Unemployment	8,708.25	0.00	0.00
Total:	1,863.45	1,863.45	665.97

DEDUCTIONS

Code	Subject To	Employee	Employer
400	8,737.75	436.88	378.34
520	0.00	250.00	0.00
550	0.00	29.50	0.00
590	0.00	0.00	317.46
595	0.00	2.86	0.00
Total:	719.24	719.24	695.80

RECAP 3240 - County Court Law

Earnings: 8,737.75 Benefits: 0.00 Deductions: 719.24 Taxes: 1,863.45 Net Pay: 6,155.06

Department: 3251 - JP Prect. 1

Total Direct Deposits: 2,505.50
 Total Check Amounts: 0.00

EARNINGS

Pay Code	Units	Pay Amount
165 Stipend w/RET	0.00	16.15
Hourly	152.00	2,393.71
S	8.00	124.04
SAL	1.00	1,541.36
Total:	161.00	4,075.26

TAXES

Code	Subject To	Employee	Employer
Federal W/H	3,051.14	220.11	0.00
MC	3,254.91	47.20	47.20
SS	3,254.91	201.80	201.80
Unemployment	2,493.75	0.00	0.00
Total:	12,054.71	469.11	249.00

DEDUCTIONS

Code	Subject To	Employee	Employer
400	4,075.26	203.77	176.46
550	0.00	51.81	0.00
551	0.00	189.00	0.00
560	0.00	75.00	0.00
580	0.00	1.53	0.00
590	0.00	506.57	967.38
615	0.00	72.97	0.00
Total:	4,075.26	1,100.65	1,143.84

RECAP 3251 - JP Prect. 1

Earnings: 4,075.26 Benefits: 0.00 Deductions: 1,100.65 Taxes: 469.11 Net Pay: 2,505.50

Department: 3252 - JP Prect. 2

Total Direct Deposits: 3,168.78
 Total Check Amounts: 0.00

EARNINGS

Pay Code	Units	Pay Amount
165 Stipend w/RET	0.00	16.15
Hourly	128.00	2,017.92
SAL	1.00	1,541.36
Vacation	32.00	510.96
Total:	161.00	4,086.39

TAXES

Code	Subject To	Employee	Employer
Federal W/H	3,775.59	284.25	0.00
MC	3,979.92	57.71	57.71
SS	3,979.92	246.76	246.76
Unemployment	4,059.16	0.00	0.00
Total:	15,794.59	588.72	304.47

DEDUCTIONS

Code	Subject To	Employee	Employer
400	4,086.39	204.33	176.94
550	0.00	27.23	0.00
580	0.00	4.59	0.00
590	0.00	0.00	952.38
595	0.00	8.44	0.00
610	0.00	13.50	0.00
615	0.00	70.80	0.00
Total:	4,086.39	328.89	1,129.32

RECAP 3252 - JP Prect. 2

Earnings: 4,086.39 Benefits: 0.00 Deductions: 328.89 Taxes: 588.72 Net Pay: 3,168.78

Department: 3253 - JP Prect. 3

Total Direct Deposits: 2,444.46
 Total Check Amounts: 0.00

EARNINGS

Pay Code	Units	Pay Amount
165 Stipend w/RET	0.00	16.15
Hourly	112.00	1,589.63
S	8.00	127.74
SAL	1.00	1,541.36
Total:	121.00	3,274.88

TAXES

Code	Subject To	Employee	Employer
Federal W/H	2,892.52	214.25	0.00
MC	3,056.27	44.32	44.32
SS	3,056.27	189.49	189.49
Unemployment	3,247.65	0.00	0.00
Total:	448.06	233.81	

DEDUCTIONS

Code	Subject To	Employee	Employer
400	3,274.88	163.75	141.80
550	0.00	27.23	0.00
590	0.00	158.75	649.92
595	0.00	2.86	0.00
615	0.00	29.77	0.00
Total:	382.36	791.72	

RECAP 3253 - JP Prect. 3

Earnings: 3,274.88 Benefits: 0.00 Deductions: 382.36 Taxes: 448.06 Net Pay: 2,444.46

Department: 3254 - JP Prect. 4

Total Direct Deposits: 1,873.46
 Total Check Amounts: 0.00

EARNINGS

Pay Code	Units	Pay Amount
165 Stipend w/RET	0.00	16.15
Hourly	80.00	1,277.37
SAL	1.00	1,541.36
Total:	81.00	2,834.88

TAXES

Code	Subject To	Employee	Employer
Federal W/H	2,472.36	130.86	0.00
MC	2,614.11	37.90	37.90
SS	2,614.11	162.08	162.08
Unemployment	1,277.37	0.00	0.00
Total:	330.84	199.98	

DEDUCTIONS

Code	Subject To	Employee	Employer
400	2,834.88	141.75	122.75
530	0.00	230.77	0.00
540	0.00	34.23	0.00
551	0.00	40.00	0.00
580	0.00	3.06	0.00
590	0.00	158.75	649.92
615	0.00	22.02	0.00
Total:	630.58	772.67	

RECAP 3254 - JP Prect. 4

Earnings: 2,834.88 Benefits: 0.00 Deductions: 630.58 Taxes: 330.84 Net Pay: 1,873.46

Department: 4300 - County Sheriff

Total Direct Deposits: 51,533.98
 Total Check Amounts: 0.00

EARNINGS

Pay Code	Units	Pay Amount
165 Stipend w/RET	0.00	533.09
Hourly	2,524.00	48,991.39
LWP	85.50	1,558.37
OT	40.00	1,021.44
S	34.00	630.12
SAL	4.00	9,973.53
Uniform	0.00	875.00
Vacation	203.00	3,947.70
Total:	2,890.50	67,530.64

TAXES

Code	Subject To	Employee	Employer
Federal W/H	62,284.13	5,353.40	0.00
MC	65,760.66	953.54	953.54
SS	65,760.66	4,077.15	4,077.15
Unemployment	64,137.53	0.00	0.00
Total:		10,384.09	5,030.69

DEDUCTIONS

Code	Subject To	Employee	Employer
400	67,530.64	3,376.53	2,924.07
520	0.00	100.00	0.00
530	0.00	216.00	0.00
540	0.00	38.13	0.00
550	0.00	341.19	0.00
551	0.00	416.00	0.00
580	0.00	27.54	0.00
590	0.00	635.00	10,853.64
595	0.00	17.02	0.00
610	0.00	84.39	0.00
615	0.00	360.77	0.00
Total:		5,612.57	13,777.71

RECAP 4300 - County Sheriff

Earnings: 67,530.64 Benefits: 0.00 Deductions: 5,612.57 Taxes: 10,384.09 Net Pay: 51,533.98

Department: 4310 - County Jail

Total Direct Deposits: 62,377.65
 Total Check Amounts: 3,113.02

EARNINGS

Pay Code	Units	Pay Amount
165 Stipend w/RET	0.00	295.00
BEREAVEMENT	36.00	897.32
Hourly	3,711.25	66,271.21
LWOP	89.50	0.00
LWP	24.00	416.91
OT	176.35	4,578.97
S	234.00	4,311.97
SAL	-61.00	5,329.96
Uniform	0.00	1,025.00
Vacation	64.75	1,464.37
VAC-PAYOUT	70.06	1,217.02
Total:	4,344.91	85,807.73

TAXES

Code	Subject To	Employee	Employer
Federal W/H	79,473.15	7,001.69	0.00
MC	83,863.57	1,216.03	1,216.03
SS	83,863.57	5,199.54	5,199.54
Unemployment	85,429.03	0.00	0.00
Total:	13,417.26	6,415.57	

DEDUCTIONS

Code	Subject To	Employee	Employer
400	85,807.73	4,290.42	3,715.47
520	0.00	100.00	0.00
530	0.00	323.54	0.00
550	0.00	378.70	0.00
551	0.00	237.55	0.00
580	0.00	19.89	0.00
590	0.00	793.75	15,313.08
595	0.00	42.48	0.00
610	0.00	42.76	0.00
615	0.00	491.68	0.00
620	0.00	179.03	0.00
Total:	6,899.80	19,028.55	

RECAP 4310 - County Jail

Earnings: 85,807.73 Benefits: 0.00 Deductions: 6,899.80 Taxes: 13,417.26 Net Pay: 65,490.67

Department: 4321 - Constables-Pct. 1

Total Direct Deposits: 1,322.75
 Total Check Amounts: 0.00

EARNINGS

Pay Code	Units	Pay Amount
165 Stipend w/RET	0.00	16.15
Hourly	49.00	643.37
SAL	1.00	996.98
Total:	50.00	1,656.50

TAXES

Code	Subject To	Employee	Employer
Federal W/H	1,573.67	124.20	0.00
MC	1,656.50	24.02	24.02
SS	1,656.50	102.70	102.70
Unemployment	643.37	0.00	0.00
Total:	250.92	126.72	

DEDUCTIONS

Code	Subject To	Employee	Employer
400	1,656.50	82.83	71.73
Total:	82.83	71.73	

RECAP 4321 - Constables-Pct. 1

Earnings: 1,656.50 Benefits: 0.00 Deductions: 82.83 Taxes: 250.92 Net Pay: 1,322.75

Department: 4322 - Constables-Pct. 2

Total Direct Deposits: 1,300.13
 Total Check Amounts: 0.00

EARNINGS

Pay Code	Units	Pay Amount
165 Stipend w/RET	0.00	16.15
Hourly	78.00	1,024.14
SAL	1.00	996.98
Total:	79.00	2,037.27

TAXES

Code	Subject To	Employee	Employer
Federal W/H	1,809.64	363.27	0.00
MC	1,911.50	27.72	27.72
SS	1,911.50	118.52	118.52
Unemployment	2,023.65	0.00	0.00
Total:	509.51	509.51	146.24

DEDUCTIONS

Code	Subject To	Employee	Employer
400	2,037.27	101.86	88.22
550	0.00	13.62	0.00
551	0.00	96.00	0.00
590	0.00	0.00	317.46
615	0.00	16.15	0.00
Total:	227.63	227.63	405.68

RECAP 4322 - Constables-Pct. 2

Earnings: 2,037.27 Benefits: 0.00 Deductions: 227.63 Taxes: 509.51 Net Pay: 1,300.13

Department: 4323 - Constables-Pct. 3

Total Direct Deposits: 1,404.14
 Total Check Amounts: 0.00

EARNINGS

Pay Code	Units	Pay Amount
165 Stipend w/RET	0.00	16.15
Hourly	65.00	853.45
SAL	1.00	996.98
Total:	66.00	1,866.58

TAXES

Code	Subject To	Employee	Employer
Federal W/H	1,562.98	30.61	0.00
MC	1,656.31	24.01	24.01
SS	1,656.31	102.69	102.69
Unemployment	1,837.08	0.00	0.00
Total:	157.31	157.31	126.70

DEDUCTIONS

Code	Subject To	Employee	Employer
400	1,866.58	93.33	80.83
550	0.00	29.50	0.00
580	0.00	1.53	0.00
590	0.00	158.75	332.46
615	0.00	22.02	0.00
Total:	305.13	305.13	413.29

RECAP 4323 - Constables-Pct. 3

Earnings: 1,866.58 Benefits: 0.00 Deductions: 305.13 Taxes: 157.31 Net Pay: 1,404.14

Department: 4324 - Constables-Pct. 4

Total Direct Deposits: 1,420.03
 Total Check Amounts: 0.00

EARNINGS

Pay Code	Units	Pay Amount
165 Stipend w/RET	0.00	16.15
Hourly	83.50	1,096.36
SAL	1.00	996.98
Total:	84.50	2,109.49

TAXES

Code	Subject To	Employee	Employer
Federal W/H	1,713.58	149.80	0.00
MC	1,859.06	26.95	26.95
SS	1,859.06	115.27	115.27
Unemployment	1,096.36	0.00	0.00
Total:	292.02	142.22	

DEDUCTIONS

Code	Subject To	Employee	Employer
400	2,109.49	105.48	91.35
520	0.00	40.00	0.00
550	0.00	18.92	0.00
551	0.00	45.00	0.00
580	0.00	1.53	0.00
590	0.00	158.75	332.46
595	0.00	5.74	0.00
615	0.00	22.02	0.00
Total:	397.44	423.81	

RECAP 4324 - Constables-Pct. 4

Earnings: 2,109.49 Benefits: 0.00 Deductions: 397.44 Taxes: 292.02 Net Pay: 1,420.03

Department: 4330 - Driver's License

Total Direct Deposits: 525.94
 Total Check Amounts: 0.00

EARNINGS

Pay Code	Units	Pay Amount
Hourly	48.00	617.28
Total:	48.00	617.28

TAXES

Code	Subject To	Employee	Employer
Federal W/H	586.42	13.26	0.00
MC	617.28	8.95	8.95
SS	617.28	38.27	38.27
Unemployment	617.28	0.00	0.00
Total:	60.48	47.22	

DEDUCTIONS

Code	Subject To	Employee	Employer
400	617.28	30.86	26.73
Total:	30.86	26.73	

RECAP 4330 - Driver's License

Earnings: 617.28 Benefits: 0.00 Deductions: 30.86 Taxes: 60.48 Net Pay: 525.94

Department: 5401 - Juvenile Probation

Total Direct Deposits: 13,704.82
 Total Check Amounts: 0.00

EARNINGS

Pay Code	Units	Pay Amount
165 Stipend w/RET	0.00	129.20
Hourly	475.25	11,073.87
JP COMP TAKEN	31.00	853.65
S	20.00	440.81
SAL	-6.00	5,671.10
Vacation	41.75	1,176.16
Total:	562.00	19,344.79

BENEFITS

Pay Code	Units	Pay Amount
JP COMP EARNED	8.50	210.16
Total:	8.50	210.16

TAXES

Code	Subject To	Employee	Employer
Federal W/H	16,453.47	1,389.58	0.00
MC	17,665.72	256.15	256.15
SS	17,665.72	1,095.27	1,095.27
Unemployment	19,344.79	0.00	0.00
Total:	16,453.47	2,741.00	1,351.42

DEDUCTIONS

Code	Subject To	Employee	Employer
400	19,344.79	967.25	837.63
520	0.00	245.00	0.00
551	0.00	536.00	0.00
552	0.00	376.00	0.00
580	0.00	7.65	0.00
590	0.00	650.26	2,584.68
595	0.00	2.86	0.00
615	0.00	113.95	0.00
Total:	19,344.79	2,898.97	3,422.31

RECAP 5401 - Juvenile Probation

Earnings:	19,344.79	Benefits:	210.16	Deductions:	2,898.97	Taxes:	2,741.00	Net Pay:	13,704.82
-----------	-----------	-----------	--------	-------------	----------	--------	----------	----------	-----------

Department: 6520 - Building Maintenance

Total Direct Deposits: 6,489.30
 Total Check Amounts: 0.00

EARNINGS

Pay Code	Units	Pay Amount
165 Stipend w/RET	0.00	48.45
Hourly	392.00	6,483.29
SAL	1.00	1,712.66
Vacation	8.00	156.67
Total:	401.00	8,401.07

TAXES

Code	Subject To	Employee	Employer
Federal W/H	7,785.09	648.13	0.00
MC	8,205.14	118.97	118.97
SS	8,205.14	508.73	508.73
Unemployment	8,327.62	0.00	0.00
Total:	7,785.09	1,275.83	627.70

DEDUCTIONS

Code	Subject To	Employee	Employer
400	8,401.07	420.05	363.78
550	0.00	73.45	0.00
551	0.00	90.00	0.00
580	0.00	6.12	0.00
590	0.00	0.00	1,904.76
595	0.00	8.58	0.00
610	0.00	13.84	0.00
615	0.00	23.90	0.00
Total:	8,401.07	635.94	2,268.54

RECAP 6520 - Building Maintenance

Earnings:	8,401.07	Benefits:	0.00	Deductions:	635.94	Taxes:	1,275.83	Net Pay:	6,489.30
-----------	----------	-----------	------	-------------	--------	--------	----------	----------	----------

Department: 6550 - Elections

Total Direct Deposits: 2,071.50
 Total Check Amounts: 0.00

EARNINGS

Pay Code	Units	Pay Amount
Hourly	72.00	1,123.09
S	8.00	124.79
SAL	1.00	1,746.92
Total:	81.00	2,994.80

TAXES

Code	Subject To	Employee	Employer
Federal W/H	2,403.58	108.90	0.00
MC	2,613.32	37.90	37.90
SS	2,613.32	162.03	162.03
Unemployment	2,974.03	0.00	0.00
Total:		308.83	199.93

DEDUCTIONS

Code	Subject To	Employee	Employer
400	2,994.80	149.74	129.67
520	0.00	60.00	0.00
550	0.00	20.77	0.00
551	0.00	112.00	0.00
580	0.00	3.06	0.00
590	0.00	158.75	649.92
595	0.00	8.31	0.00
610	0.00	20.19	0.00
615	0.00	81.65	0.00
Total:		614.47	779.59

RECAP 6550 - Elections

Earnings:	2,994.80	Benefits:	0.00	Deductions:	614.47	Taxes:	308.83	Net Pay:	2,071.50
-----------	----------	-----------	------	-------------	--------	--------	--------	----------	----------

Department: 6560 - Commissioners Court

Total Direct Deposits: 7,572.35
 Total Check Amounts: 0.00

EARNINGS

Pay Code	Units	Pay Amount
165 Stipend w/RET	0.00	212.51
Hourly	80.00	1,626.36
SAL	5.00	8,733.73
Total:	85.00	10,572.60

TAXES

Code	Subject To	Employee	Employer
Federal W/H	8,969.12	665.61	0.00
MC	9,497.74	137.71	137.71
SS	9,497.74	588.86	588.86
Unemployment	8,818.44	0.00	0.00
Total:		1,392.18	726.57

DEDUCTIONS

Code	Subject To	Employee	Employer
400	10,572.60	528.62	457.81
550	0.00	54.47	0.00
551	0.00	96.00	0.00
580	0.00	4.59	0.00
590	0.00	824.27	1,949.76
595	0.00	11.19	0.00
615	0.00	88.93	0.00
Total:		1,608.07	2,407.57

RECAP 6560 - Commissioners Court

Earnings:	10,572.60	Benefits:	0.00	Deductions:	1,608.07	Taxes:	1,392.18	Net Pay:	7,572.35
-----------	-----------	-----------	------	-------------	----------	--------	----------	----------	----------

Department: 6570 - Veteran Service Officer

Total Direct Deposits: 1,008.62
 Total Check Amounts: 0.00

EARNINGS

Pay Code	Units	Pay Amount
165 Stipend w/RET	0.00	16.15
SAL	1.00	1,292.30
Total:	1.00	1,308.45

TAXES

Code	Subject To	Employee	Employer
Federal W/H	1,213.26	106.82	0.00
MC	1,278.68	18.54	18.54
SS	1,278.68	79.28	79.28
Unemployment	1,294.83	0.00	0.00
Total:		204.64	97.82

DEDUCTIONS

Code	Subject To	Employee	Employer
400	1,308.45	65.42	56.66
550	0.00	13.62	0.00
590	0.00	0.00	317.46
615	0.00	16.15	0.00
Total:		95.19	374.12

RECAP 6570 - Veteran Service Officer

Earnings:	1,308.45	Benefits:	0.00	Deductions:	95.19	Taxes:	204.64	Net Pay:	1,008.62
-----------	----------	-----------	------	-------------	-------	--------	--------	----------	----------

Department: 6580 - Human Resources

Total Direct Deposits: 990.91
 Total Check Amounts: 0.00

EARNINGS

Pay Code	Units	Pay Amount
SAL	1.00	1,663.85
Total:	1.00	1,663.85

TAXES

Code	Subject To	Employee	Employer
Federal W/H	1,559.29	442.73	0.00
MC	1,642.48	23.82	23.82
SS	1,642.48	101.83	101.83
Unemployment	1,650.23	0.00	0.00
Total:		568.38	125.65

DEDUCTIONS

Code	Subject To	Employee	Employer
400	1,663.85	83.19	72.04
550	0.00	13.62	0.00
615	0.00	7.75	0.00
Total:		104.56	72.04

RECAP 6580 - Human Resources

Earnings:	1,663.85	Benefits:	0.00	Deductions:	104.56	Taxes:	568.38	Net Pay:	990.91
-----------	----------	-----------	------	-------------	--------	--------	--------	----------	--------

Department: 6590 - Purchasing

Total Direct Deposits: 1,423.49
 Total Check Amounts: 0.00

EARNINGS

Pay Code	Units	Pay Amount
165 Stipend w/RET	0.00	16.15
SAL	1.00	1,846.15
Total:	1.00	1,862.30

TAXES

Code	Subject To	Employee	Employer
Federal W/H	1,761.43	196.07	0.00
MC	1,854.55	26.89	26.89
SS	1,854.55	114.98	114.98
Unemployment	1,862.30	0.00	0.00
Total:		337.94	141.87

DEDUCTIONS

Code	Subject To	Employee	Employer
400	1,862.30	93.12	80.64
590	0.00	0.00	317.46
615	0.00	7.75	0.00
Total:		100.87	398.10

RECAP 6590 - Purchasing

Earnings:	1,862.30	Benefits:	0.00	Deductions:	100.87	Taxes:	337.94	Net Pay:	1,423.49
-----------	----------	-----------	------	-------------	--------	--------	--------	----------	----------

Department: 6610 - IT-Technology

Total Direct Deposits: 3,323.27
 Total Check Amounts: 0.00

EARNINGS

Pay Code	Units	Pay Amount
165 Stipend w/RET	0.00	69.24
Hourly	80.00	1,777.91
S	8.00	272.97
SAL	-7.00	2,456.70
Total:	81.00	4,576.82

TAXES

Code	Subject To	Employee	Employer
Federal W/H	4,051.67	382.58	0.00
MC	4,480.51	64.97	64.97
SS	4,480.51	277.79	277.79
Unemployment	4,532.71	0.00	0.00
Total:	725.34	342.76	

DEDUCTIONS

Code	Subject To	Employee	Employer
400	4,576.82	228.84	198.17
520	0.00	200.00	0.00
550	0.00	44.11	0.00
551	0.00	36.00	0.00
580	0.00	3.06	0.00
590	0.00	0.00	634.92
615	0.00	16.20	0.00
Total:	528.21	833.09	

RECAP 6610 - IT-Technology

Earnings:	4,576.82	Benefits:	0.00	Deductions:	528.21	Taxes:	725.34	Net Pay:	3,323.27
-----------	----------	-----------	------	-------------	--------	--------	--------	----------	----------

Department: 6630 - Grant Writing

Total Direct Deposits: 1,727.05
 Total Check Amounts: 0.00

EARNINGS

Pay Code	Units	Pay Amount
165 Stipend w/RET	0.00	16.15
SAL	1.00	2,115.38
Total:	1.00	2,131.53

TAXES

Code	Subject To	Employee	Employer
Federal W/H	2,024.95	134.84	0.00
MC	2,131.53	30.91	30.91
SS	2,131.53	132.15	132.15
Unemployment	2,131.53	0.00	0.00
Total:	297.90	163.06	

DEDUCTIONS

Code	Subject To	Employee	Employer
400	2,131.53	106.58	92.30
Total:	106.58	92.30	

RECAP 6630 - Grant Writing

Earnings:	2,131.53	Benefits:	0.00	Deductions:	106.58	Taxes:	297.90	Net Pay:	1,727.05
-----------	----------	-----------	------	-------------	--------	--------	--------	----------	----------

Department: 6640 - Code Investigator

Total Direct Deposits: 1,265.65
 Total Check Amounts: 0.00

EARNINGS

Pay Code	Units	Pay Amount
165 Stipend w/RET	0.00	34.62
Hourly	80.00	1,538.10
Total:	80.00	1,572.72

TAXES

Code	Subject To	Employee	Employer
Federal W/H	1,474.08	88.12	0.00
MC	1,552.72	22.51	22.51
SS	1,552.72	96.27	96.27
Unemployment	1,572.72	0.00	0.00
Total:		206.90	118.78

DEDUCTIONS

Code	Subject To	Employee	Employer
400	1,572.72	78.64	68.10
551	0.00	20.00	0.00
580	0.00	1.53	0.00
590	0.00	0.00	317.46
Total:		100.17	385.56

RECAP 6640 - Code Investigator

Earnings: 1,572.72 Benefits: 0.00 Deductions: 100.17 Taxes: 206.90 Net Pay: 1,265.65

Department: 6650 - Emerg Mgnt/Homeland Sec

Total Direct Deposits: 2,945.77
 Total Check Amounts: 0.00

EARNINGS

Pay Code	Units	Pay Amount
165 Stipend w/RET	0.00	69.24
Hourly	80.00	1,569.92
OT	8.00	235.49
SAL	1.00	2,170.57
Total:	89.00	4,045.22

TAXES

Code	Subject To	Employee	Employer
Federal W/H	3,612.96	363.85	0.00
MC	3,965.22	57.50	57.50
SS	3,965.22	245.84	245.84
Unemployment	4,003.24	0.00	0.00
Total:		667.19	303.34

DEDUCTIONS

Code	Subject To	Employee	Employer
400	4,045.22	202.26	175.15
520	0.00	150.00	0.00
550	0.00	41.98	0.00
590	0.00	0.00	634.92
595	0.00	5.72	0.00
615	0.00	32.30	0.00
Total:		432.26	810.07

RECAP 6650 - Emerg Mgnt/Homeland Sec

Earnings: 4,045.22 Benefits: 0.00 Deductions: 432.26 Taxes: 667.19 Net Pay: 2,945.77

Department: 7610 - Sanitation Department

Total Direct Deposits: 0.00
 Total Check Amounts: 1,599.14

EARNINGS

Pay Code	Units	Pay Amount
165 Stipend w/RET	0.00	34.62
Hourly	72.00	1,713.92
Vacation	8.00	190.44
Total:	80.00	1,938.98

TAXES

Code	Subject To	Employee	Employer
Federal W/H	1,842.03	40.97	0.00
MC	1,938.98	28.12	28.12
SS	1,938.98	120.22	120.22
Unemployment	1,938.98	0.00	0.00
Total:	189.31	148.34	

DEDUCTIONS

Code	Subject To	Employee	Employer
400	1,938.98	96.95	83.96
540	0.00	52.05	0.00
580	0.00	1.53	0.00
590	0.00	0.00	317.46
Total:	150.53	401.42	

RECAP 7610 - Sanitation Department

Earnings: 1,938.98 Benefits: 0.00 Deductions: 150.53 Taxes: 189.31 Net Pay: 1,599.14

Department: 8700 - County Agent

Total Direct Deposits: 3,790.82
 Total Check Amounts: 0.00

EARNINGS

Pay Code	Units	Pay Amount
FLOAT	8.00	134.81
Hourly	72.00	1,213.25
SAL	3.00	3,354.07
Total:	83.00	4,702.13

TAXES

Code	Subject To	Employee	Employer
Federal W/H	4,536.87	386.27	0.00
MC	4,683.12	67.90	67.90
SS	4,683.12	290.35	290.35
Unemployment	4,702.13	0.00	0.00
Total:	744.52	358.25	

DEDUCTIONS

Code	Subject To	Employee	Employer
400	2,924.98	146.25	126.65
580	0.00	1.53	0.00
590	0.00	0.00	634.92
595	0.00	2.86	0.00
615	0.00	16.15	0.00
Total:	166.79	761.57	

RECAP 8700 - County Agent

Earnings: 4,702.13 Benefits: 0.00 Deductions: 166.79 Taxes: 744.52 Net Pay: 3,790.82



Detail Register

Payroll Summary

Packet: PYPKT01284 - 033119 thru 041319 PP with Pay Date 041819
 Payroll Set: 01 - Payroll Set 01

Pay Period: 03/31/2019 - 04/13/2019

Total Direct Deposits: 274,409.38
 Total Check Amounts: 11,678.41

Males Paid: 131
 Females Paid: 114
 Total Employees: 245

EARNINGS

Pay Code	Units	Pay Amount
165 Stipend w/RET	0.00	1,702.84
BEREAVEMENT	60.00	1,334.76
DA Supplement	0.00	151.67
FLOAT	40.00	902.00
Hourly	13,684.30	247,287.34
JP COMP TAKEN	31.00	853.65
Jud Stip	0.00	3,230.77
Longevity w/RET	0.00	204.62
LWOP	89.50	0.00
LWP	109.50	1,975.28
OT	245.35	6,428.56
S	569.25	11,914.97
SAL	-171.50	91,489.24
Uniform	0.00	2,100.00
Vacation	546.45	11,548.85
VAC-PAYOUT	70.06	1,217.02
Total:	15,273.91	382,341.57

BENEFITS

Pay Code	Units	Pay Amount
JP COMP EARNED	8.50	210.16
Total:	8.50	210.16

TAXES

Code	Subject To	Employee	Employer
Federal W/H	346,653.13	30,141.02	0.00
MC	367,516.38	5,329.01	5,329.01
SS	367,516.38	22,786.06	22,786.06
Unemployment	366,775.03	0.00	0.00
Total:		58,256.09	28,115.07

DEDUCTIONS

Code	Subject To	Employee	Employer
400	380,564.42	19,028.25	16,478.48
520	0.00	1,835.00	0.00
530	0.00	770.31	0.00
540	0.00	165.46	0.00
550	0.00	1,802.43	0.00
551	0.00	2,984.55	0.00
552	0.00	476.00	0.00
560	0.00	75.00	0.00
580	0.00	153.00	0.00
590	0.00	7,106.88	64,349.46
595	0.00	200.99	0.00
610	0.00	218.64	0.00
615	0.00	2,254.34	0.00
620	0.00	397.75	0.00
Bankruptcy	0.00	529.09	0.00
Total:		37,997.69	80,827.94

RECAP 01 - Payroll Set 01

Earnings:	382,341.57	Benefits:	210.16	Deductions:	37,997.69	Taxes:	58,256.09	Net Pay:	286,087.79
-----------	------------	-----------	--------	-------------	-----------	--------	-----------	----------	------------

**B. \$86,371.16 (Payroll Tax for 03/31/2019
– 04/13/2019); Backup: 2**

Caldwell County Agenda Item Request Form

To: All Elected Officials and Department Heads – Hand deliver or scan & email to hoppy.haden@co.caldwell.tx.us and ezyy.chan@co.caldwell.tx.us . Deadline is 5:00 pm Tuesday before the Regular meetings, however, please submit this completed form ASAP. "Anything missing will cause the Agenda Item to be held over to the next Regular meeting," according to our Rules & Procedures.

AGENDA DATE: 5/13/2019

Type of Agenda Item

- Consent Discussion/Action Executive Session Workshop
 Public Hearing

What will be discussed? What is the proposed motion?

to approve 3/31/19-4/13/19 Payroll Tax in the amount of \$86,371.16

1. **Costs:**

Actual Cost or Estimated Cost \$ 86,371.16

Is this cost included in the County Budget? yes

Is a Budget Amendment being proposed? no

2. **Agenda Speakers:**

	Name	Representing	Title
--	------	--------------	-------

(1) _____

(2) _____

(3) _____

3. **Backup Materials:** None To Be Distributed 2 total # of backup pages
(including this page)

4. 
Signature of Court Member

Date 5/7/2019



Detail Register

Payroll Summary

Packet: PYPKT01284 - 033119 thru 041319 PP with Pay Date 041819
 Payroll Set: 01 - Payroll Set 01

Pay Period: 03/31/2019 - 04/13/2019

Total Direct Deposits: 274,409.38
 Total Check Amounts: 11,678.41

Males Paid: 131
 Females Paid: 114
 Total Employees: 245

EARNINGS

Pay Code	Units	Pay Amount
165 Stipend w/RET	0.00	1,702.84
BEREAVEMENT	60.00	1,334.76
DA Supplement	0.00	151.67
FLOAT	40.00	902.00
Hourly	13,684.30	247,287.34
JP COMP TAKEN	31.00	853.65
Jud Stip	0.00	3,230.77
Longevity w/RET	0.00	204.62
LWOP	89.50	0.00
LWP	109.50	1,975.28
OT	245.35	6,428.56
S	569.25	11,914.97
SAL	-171.50	91,489.24
Uniform	0.00	2,100.00
Vacation	546.45	11,548.85
VAC-PAYOUT	70.06	1,217.02
Total:	15,273.91	382,341.57

BENEFITS

Pay Code	Units	Pay Amount
JP COMP EARNED	8.50	210.16
Total:	8.50	210.16

TAXES

Code	Subject To	Employee	Employer
Federal W/H	346,653.13	30,141.02	0.00
MC	367,516.38	5,329.01	5,329.01
SS	367,516.38	22,786.06	22,786.06
Unemployment	366,775.03	0.00	0.00
Total:		58,256.09	28,115.07

Handwritten: \$86,371.16

DEDUCTIONS

Code	Subject To	Employee	Employer
400	380,564.42	19,028.25	16,478.48
520	0.00	1,835.00	0.00
530	0.00	770.31	0.00
540	0.00	165.46	0.00
550	0.00	1,802.43	0.00
551	0.00	2,984.55	0.00
552	0.00	476.00	0.00
560	0.00	75.00	0.00
580	0.00	153.00	0.00
590	0.00	7,106.88	64,349.46
595	0.00	200.99	0.00
610	0.00	218.64	0.00
615	0.00	2,254.34	0.00
620	0.00	397.75	0.00
Bankruptcy	0.00	529.09	0.00
Total:		37,997.69	80,827.94

RECAP 01 - Payroll Set 01

Earnings:	382,341.57	Benefits:	210.16	Deductions:	37,997.69	Taxes:	58,256.09	Net Pay:	286,087.79
-----------	------------	-----------	--------	-------------	-----------	--------	-----------	----------	------------

**C. \$291,588.34 (Payroll for 4/14/19 –
4/27/19); Backup: 21**

Caldwell County Agenda Item Request Form

To: All Elected Officials and Department Heads – Hand deliver or scan & email to hoppy.haden@co.caldwell.tx.us and ezzy.chan@co.caldwell.tx.us . Deadline is 5:00 pm Tuesday before the Regular meetings, however, please submit this completed form ASAP. "Anything missing will cause the Agenda Item to be held over to the next Regular meeting," according to our Rules & Procedures.

AGENDA DATE: 5/13/2019

Type of Agenda Item

- Consent Discussion/Action Executive Session Workshop
- Public Hearing

What will be discussed? What is the proposed motion?

to accept the 4/14/19 - 4/27/19 Payroll in the amount of \$291,588.34

1. Costs:

Actual Cost or Estimated Cost \$ _____

Is this cost included in the County Budget? _____

Is a Budget Amendment being proposed? _____

2. Agenda Speakers:

	Name	Representing	Title
(1)	_____		
(2)	_____		
(3)	_____		

3. Backup Materials: None To Be Distributed 21 total # of backup pages (including this page)

4. 
Signature of Court Member

Date 5/7/2019

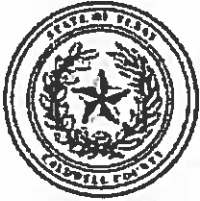

Caldwell County, TX

Detail Register

Department Summary

Packet: PYPKT01291 - 041419 thru 042719 Payroll Pay Date 050319
 Payroll Set: 01 - Payroll Set 01

Pay Period: 04/14/2019 - 04/27/2019

Department: 1000 - Courthouse Security

Total Direct Deposits: 9,372.92
 Total Check Amounts: 0.00

EARNINGS

Pay Code	Units	Pay Amount
112 - Holiday	64.00	1,199.95
165 Stipend w/RET	0.00	16.15
Hourly	566.00	10,617.44
OT	4.00	109.36
S	12.00	218.72
Uniform	0.00	200.00
Total:	646.00	12,361.62

TAXES

Code	Subject To	Employee	Employer
Federal W/H	11,366.61	851.99	0.00
MC	11,984.71	173.78	173.78
SS	11,984.71	743.08	743.08
Unemployment	12,224.33	0.00	0.00
Total:		1,768.85	916.86

DEDUCTIONS

Code	Subject To	Employee	Employer
400	12,361.62	618.10	535.27
550	0.00	137.29	0.00
580	0.00	6.12	0.00
590	0.00	158.75	1,284.84
595	0.00	8.60	0.00
615	0.00	72.27	0.00
620	0.00	218.72	0.00
Total:		1,219.85	1,820.11

RECAP 1000 - Courthouse Security

Earnings:	12,361.62	Benefits:	0.00	Deductions:	1,219.85	Taxes:	1,768.85	Net Pay:	9,372.92
-----------	-----------	-----------	------	-------------	----------	--------	----------	----------	----------

Department: 1101 - Unit Road

Total Direct Deposits: 23,327.24
 Total Check Amounts: 2,096.09

EARNINGS

Pay Code	Units	Pay Amount
112 - Holiday	184.00	3,213.62
16S Stipend w/RET	0.00	66.92
BEREAVEMENT	24.00	484.98
Hourly	1,528.25	26,631.45
S	11.75	200.30
SAL	-7.00	1,667.83
Vacation	100.00	1,790.70
Total:	1,841.00	34,055.80

TAXES

Code	Subject To	Employee	Employer
Federal W/H	30,977.40	2,509.63	0.00
MC	32,680.18	473.88	473.88
SS	32,680.18	2,026.17	2,026.17
Unemployment	33,902.72	0.00	0.00
Total:		5,009.68	2,500.05

DEDUCTIONS

Code	Subject To	Employee	Employer
400	34,055.80	1,702.78	1,474.62
530	0.00	0.00	0.00
550	0.00	153.08	0.00
551	0.00	68.00	0.00
580	0.00	15.30	0.00
590	0.00	983.02	7,044.12
595	0.00	19.34	0.00
610	0.00	0.00	0.00
615	0.00	152.18	0.00
Bankruptcy	0.00	529.09	0.00
Total:		3,622.79	8,518.74

RECAP 1101 - Unit Road

Earnings: 34,055.80 Benefits: 0.00 Deductions: 3,622.79 Taxes: 5,009.68 Net Pay: 25,423.33

Department: 1102 - Vehicle Maintenance

Total Direct Deposits: 980.54
 Total Check Amounts: 2,391.74

EARNINGS

Pay Code	Units	Pay Amount
112 - Holiday	24.00	429.50
Hourly	196.75	3,527.38
S	11.25	196.34
Vacation	8.00	141.78
Total:	240.00	4,295.00

TAXES

Code	Subject To	Employee	Employer
Federal W/H	4,031.13	332.51	0.00
MC	4,245.88	61.57	61.57
SS	4,245.88	263.24	263.24
Unemployment	4,282.03	0.00	0.00
Total:		657.32	324.81

DEDUCTIONS

Code	Subject To	Employee	Employer
400	4,295.00	214.75	185.97
550	0.00	12.97	0.00
551	0.00	20.00	0.00
580	0.00	1.53	0.00
590	0.00	0.00	952.38
615	0.00	16.15	0.00
Total:		265.40	1,138.35

RECAP 1102 - Vehicle Maintenance

Earnings: 4,295.00 Benefits: 0.00 Deductions: 265.40 Taxes: 657.32 Net Pay: 3,372.28

Department: 1103 - Fleet Maintenance

Total Direct Deposits: 1,251.17
 Total Check Amounts: 1,157.89

EARNINGS

Pay Code	Units	Pay Amount
112 - Holiday	16.00	298.28
Hourly	136.00	2,529.57
S	8.00	154.96
Total:	160.00	2,982.81

TAXES

Code	Subject To	Employee	Employer
Federal W/H	2,817.47	179.94	0.00
MC	2,966.61	43.01	43.01
SS	2,966.61	183.93	183.93
Unemployment	2,982.81	0.00	0.00
Total:		406.88	226.94

DEDUCTIONS

Code	Subject To	Employee	Employer
400	2,982.81	149.14	129.16
580	0.00	1.53	0.00
590	0.00	0.00	634.92
615	0.00	16.20	0.00
Total:		166.87	764.08

RECAP 1103 - Fleet Maintenance

Earnings: 2,982.81 Benefits: 0.00 Deductions: 166.87 Taxes: 406.88 Net Pay: 2,409.06

Department: 2120 - County Treasurer

Total Direct Deposits: 2,638.18
 Total Check Amounts: 0.00

EARNINGS

Pay Code	Units	Pay Amount
112 - Holiday	8.00	154.34
Hourly	69.75	1,345.67
S	1.00	19.29
SAL	1.00	1,848.25
Vacation	1.25	24.12
Total:	81.00	3,391.67

TAXES

Code	Subject To	Employee	Employer
Federal W/H	3,102.93	209.82	0.00
MC	3,312.51	48.03	48.03
SS	3,312.51	205.37	205.37
Unemployment	3,391.67	0.00	0.00
Total:		463.22	253.40

DEDUCTIONS

Code	Subject To	Employee	Employer
400	3,391.67	169.58	146.86
520	0.00	40.00	0.00
551	0.00	44.00	0.00
580	0.00	1.53	0.00
590	0.00	0.00	634.92
595	0.00	2.86	0.00
615	0.00	32.30	0.00
Total:		290.27	781.78

RECAP 2120 - County Treasurer

Earnings: 3,391.67 Benefits: 0.00 Deductions: 290.27 Taxes: 463.22 Net Pay: 2,638.18

Department: 2130 - County Auditor

Total Direct Deposits: 5,626.81
 Total Check Amounts: 0.00

EARNINGS

Pay Code	Units	Pay Amount
112 - Holiday	24.00	493.65
Hourly	214.00	4,407.75
OT	2.00	60.34
S	6.00	188.92
SAL	-11.00	2,615.38
Vacation	8.00	307.69
Total:	243.00	8,073.73

TAXES

Code	Subject To	Employee	Employer
Federal W/H	7,037.03	805.67	0.00
MC	7,640.72	110.80	110.80
SS	7,640.72	473.73	473.73
Unemployment	8,042.83	0.00	0.00
Total:		1,390.20	584.53

DEDUCTIONS

Code	Subject To	Employee	Employer
400	8,073.73	403.69	349.59
520	0.00	200.00	0.00
550	0.00	30.90	0.00
551	0.00	192.00	0.00
580	0.00	3.06	0.00
590	0.00	158.75	967.38
595	0.00	2.86	0.00
610	0.00	16.96	0.00
615	0.00	48.50	0.00
Total:		1,056.72	1,316.97

RECAP 2130 - County Auditor

Earnings: 8,073.73 Benefits: 0.00 Deductions: 1,056.72 Taxes: 1,390.20 Net Pay: 5,626.81

Department: 2140 - Tax Assessor-Collector

Total Direct Deposits: 6,197.69
 Total Check Amounts: 0.00

EARNINGS

Pay Code	Units	Pay Amount
112 - Holiday	40.00	645.31
Hourly	358.00	5,776.55
S	1.00	15.60
SAL	1.00	1,829.82
Vacation	1.00	15.60
Total:	401.00	8,282.88

TAXES

Code	Subject To	Employee	Employer
Federal W/H	7,483.20	666.83	0.00
MC	8,027.33	116.40	116.40
SS	8,027.33	497.69	497.69
Unemployment	6,425.82	0.00	0.00
Total:		1,280.92	614.09

DEDUCTIONS

Code	Subject To	Employee	Employer
400	8,282.88	414.13	358.63
520	0.00	130.00	0.00
550	0.00	27.24	0.00
551	0.00	34.00	0.00
580	0.00	4.59	0.00
590	0.00	158.75	1,919.76
595	0.00	20.06	0.00
615	0.00	15.50	0.00
Total:		804.27	2,278.39

RECAP 2140 - Tax Assessor-Collector

Earnings: 8,282.88 Benefits: 0.00 Deductions: 804.27 Taxes: 1,280.92 Net Pay: 6,197.69

Department: 2150 - County Clerk

Total Direct Deposits: 9,374.84
 Total Check Amounts: 0.00

EARNINGS

Pay Code	Units	Pay Amount
112 - Holiday	64.00	1,019.80
FLOAT	8.00	126.97
Hourly	522.65	8,335.49
S	12.50	194.79
SAL	1.00	1,868.45
Vacation	32.85	520.94
Total:	641.00	12,066.44

TAXES

Code	Subject To	Employee	Employer
Federal W/H	11,062.46	710.30	0.00
MC	11,725.77	170.03	170.03
SS	11,725.77	727.00	727.00
Unemployment	11,974.38	0.00	0.00
Total:		1,607.33	897.03

DEDUCTIONS

Code	Subject To	Employee	Employer
400	12,066.44	603.31	522.48
520	0.00	60.00	0.00
540	0.00	41.05	0.00
550	0.00	92.06	0.00
551	0.00	159.60	0.00
580	0.00	12.24	0.00
590	0.00	0.00	2,539.68
595	0.00	8.58	0.00
610	0.00	27.00	0.00
615	0.00	80.43	0.00
Total:		1,084.27	3,062.16

RECAP 2150 - County Clerk

Earnings: 12,066.44 Benefits: 0.00 Deductions: 1,084.27 Taxes: 1,607.33 Net Pay: 9,374.84

Department: 3000 - County Clerk

Total Direct Deposits: 948.01
 Total Check Amounts: 0.00

EARNINGS

Pay Code	Units	Pay Amount
112 - Holiday	8.00	129.93
Hourly	68.25	1,108.48
S	3.75	60.91
Total:	80.00	1,299.32

TAXES

Code	Subject To	Employee	Employer
Federal W/H	1,033.58	0.00	0.00
MC	1,098.55	15.93	15.93
SS	1,098.55	68.11	68.11
Unemployment	1,299.32	0.00	0.00
Total:		84.04	84.04

DEDUCTIONS

Code	Subject To	Employee	Employer
400	1,299.32	64.97	56.26
551	0.00	20.00	0.00
580	0.00	1.53	0.00
590	0.00	158.75	332.46
615	0.00	22.02	0.00
Total:		267.27	388.72

RECAP 3000 - County Clerk

Earnings: 1,299.32 Benefits: 0.00 Deductions: 267.27 Taxes: 84.04 Net Pay: 948.01

Department: 3200 - District Attorney

Total Direct Deposits: 20,473.48
 Total Check Amounts: 146.60

EARNINGS

Pay Code	Units	Pay Amount
112 - Holiday	64.00	1,220.95
165 Stipend w/RET	0.00	16.15
DA Supplement	0.00	151.67
FLOAT	8.00	276.88
Hourly	518.00	9,822.55
Longevity w/RET	0.00	204.62
S	74.00	2,118.88
SAL	-74.00	12,878.75
Vacation	56.00	1,489.84
Total:	646.00	28,180.29

TAXES

Code	Subject To	Employee	Employer
Federal W/H	25,497.95	2,802.66	0.00
MC	26,966.95	391.02	391.02
SS	26,966.95	1,671.95	1,671.95
Unemployment	27,885.28	0.00	0.00
Total:		4,865.63	2,062.97

DEDUCTIONS

Code	Subject To	Employee	Employer
400	28,180.29	1,409.00	1,220.21
520	0.00	60.00	0.00
550	0.00	127.19	0.00
551	0.00	416.00	0.00
552	0.00	100.00	0.00
580	0.00	12.24	0.00
590	0.00	476.25	4,171.98
595	0.00	8.58	0.00
615	0.00	85.32	0.00
Total:		2,694.58	5,392.19

RECAP 3200 - District Attorney

Earnings: 28,180.29 Benefits: 0.00 Deductions: 2,694.58 Taxes: 4,865.63 Net Pay: 20,620.08

Department: 3220 - District Clerk

Total Direct Deposits: 8,178.65
 Total Check Amounts: 0.00

EARNINGS

Pay Code	Units	Pay Amount
112 - Holiday	56.00	910.07
Hourly	471.50	7,635.64
S	12.50	191.82
SAL	1.00	1,874.15
Vacation	20.00	363.15
Total:	561.00	10,974.83

TAXES

Code	Subject To	Employee	Employer
Federal W/H	9,625.76	658.05	0.00
MC	10,274.50	148.97	148.97
SS	10,274.50	637.03	637.03
Unemployment	9,058.70	0.00	0.00
Total:		1,444.05	786.00

DEDUCTIONS

Code	Subject To	Employee	Employer
400	10,974.83	548.74	475.22
520	0.00	100.00	0.00
550	0.00	41.98	0.00
551	0.00	36.76	0.00
580	0.00	3.06	0.00
590	0.00	491.51	2,252.22
595	0.00	11.19	0.00
615	0.00	118.89	0.00
Total:		1,352.13	2,727.44

RECAP 3220 - District Clerk

Earnings: 10,974.83 Benefits: 0.00 Deductions: 1,352.13 Taxes: 1,444.05 Net Pay: 8,178.65

Department: 3230 - District Judge

Total Direct Deposits: 4,684.00
 Total Check Amounts: 327.56

EARNINGS

Pay Code	Units	Pay Amount
112 - Holiday	8.00	138.84
Hourly	72.00	1,249.60
SAL	3.00	5,192.93
Vacation	4.00	159.42
Total:	87.00	6,740.79

TAXES

Code	Subject To	Employee	Employer
Federal W/H	5,823.96	331.90	0.00
MC	6,261.00	90.78	90.78
SS	6,261.00	388.19	388.19
Unemployment	6,694.63	0.00	0.00
Total:	810.87	810.87	478.97

DEDUCTIONS

Code	Subject To	Employee	Employer
400	6,740.79	337.04	291.89
520	0.00	100.00	0.00
551	0.00	80.64	0.00
580	0.00	1.53	0.00
590	0.00	317.50	664.92
615	0.00	81.65	0.00
Total:	918.36	956.81	

RECAP 3230 - District Judge

Earnings: 6,740.79 Benefits: 0.00 Deductions: 918.36 Taxes: 810.87 Net Pay: 5,011.56

Department: 3240 - County Court Law

Total Direct Deposits: 6,155.06
 Total Check Amounts: 0.00

EARNINGS

Pay Code	Units	Pay Amount
Jud Stip	0.00	3,230.77
SAL	2.00	5,506.98
Total:	2.00	8,737.75

TAXES

Code	Subject To	Employee	Employer
Federal W/H	8,018.51	1,197.48	0.00
MC	8,705.39	126.23	126.23
SS	8,705.39	539.74	539.74
Unemployment	8,708.25	0.00	0.00
Total:	1,863.45	1,863.45	665.97

DEDUCTIONS

Code	Subject To	Employee	Employer
400	8,737.75	436.88	378.34
520	0.00	250.00	0.00
550	0.00	29.50	0.00
590	0.00	0.00	317.46
595	0.00	2.86	0.00
Total:	719.24	695.80	

RECAP 3240 - County Court Law

Earnings: 8,737.75 Benefits: 0.00 Deductions: 719.24 Taxes: 1,863.45 Net Pay: 6,155.06

Department: 3251 - JP Prect. 1

Total Direct Deposits: 2,505.48
 Total Check Amounts: 0.00

EARNINGS

Pay Code	Units	Pay Amount
112 - Holiday	8.00	127.74
165 Stipend w/RET	0.00	16.15
HOL	8.00	124.00
Hourly	136.00	2,138.24
S	8.00	127.74
SAL	1.00	1,541.36
Total:	161.00	4,075.23

TAXES

Code	Subject To	Employee	Employer
Federal W/H	3,051.11	220.10	0.00
MC	3,254.88	47.20	47.20
SS	3,254.88	201.80	201.80
Unemployment	2,493.72	0.00	0.00
Total:		469.10	249.00

DEDUCTIONS

Code	Subject To	Employee	Employer
400	4,075.23	203.77	176.46
550	0.00	51.81	0.00
551	0.00	189.00	0.00
560	0.00	75.00	0.00
580	0.00	1.53	0.00
590	0.00	506.57	967.38
615	0.00	72.97	0.00
Total:		1,100.65	1,143.84

RECAP 3251 - JP Prect. 1

Earnings: 4,075.23 Benefits: 0.00 Deductions: 1,100.65 Taxes: 469.10 Net Pay: 2,505.48

Department: 3252 - JP Prect. 2

Total Direct Deposits: 3,168.78
 Total Check Amounts: 0.00

EARNINGS

Pay Code	Units	Pay Amount
112 - Holiday	16.00	252.89
165 Stipend w/RET	0.00	16.15
FLOAT	8.00	127.74
Hourly	136.00	2,148.25
SAL	1.00	1,541.36
Total:	161.00	4,086.39

TAXES

Code	Subject To	Employee	Employer
Federal W/H	3,775.59	284.25	0.00
MC	3,979.92	57.71	57.71
SS	3,979.92	246.76	246.76
Unemployment	4,059.16	0.00	0.00
Total:		588.72	304.47

DEDUCTIONS

Code	Subject To	Employee	Employer
400	4,086.39	204.33	176.94
550	0.00	27.23	0.00
580	0.00	4.59	0.00
590	0.00	0.00	952.38
595	0.00	8.44	0.00
610	0.00	13.50	0.00
615	0.00	70.80	0.00
Total:		328.89	1,129.32

RECAP 3252 - JP Prect. 2

Earnings: 4,086.39 Benefits: 0.00 Deductions: 328.89 Taxes: 588.72 Net Pay: 3,168.78

Department: 3253 - JP Prec. 3

Total Direct Deposits: 2,495.84
 Total Check Amounts: 0.00

EARNINGS

Pay Code	Units	Pay Amount
112 - Holiday	8.00	127.74
165 Stipend w/RET	0.00	16.15
Hourly	118.00	1,655.63
SAL	1.00	1,541.36
Total:	127.00	3,340.88

TAXES

Code	Subject To	Employee	Employer
Federal W/H	2,955.22	220.52	0.00
MC	3,122.27	45.28	45.28
SS	3,122.27	193.58	193.58
Unemployment	3,313.65	0.00	0.00
Total:	459.38	238.86	

DEDUCTIONS

Code	Subject To	Employee	Employer
400	3,340.88	167.05	144.66
550	0.00	27.23	0.00
590	0.00	158.75	649.92
595	0.00	2.86	0.00
615	0.00	29.77	0.00
Total:	385.66	794.58	

RECAP 3253 - JP Prec. 3

Earnings: 3,340.88 Benefits: 0.00 Deductions: 385.66 Taxes: 459.38 Net Pay: 2,495.84

Department: 3254 - JP Prec. 4

Total Direct Deposits: 1,873.46
 Total Check Amounts: 0.00

EARNINGS

Pay Code	Units	Pay Amount
112 - Holiday	8.00	127.74
165 Stipend w/RET	0.00	16.15
Hourly	72.00	1,149.63
SAL	1.00	1,541.36
Total:	81.00	2,834.88

TAXES

Code	Subject To	Employee	Employer
Federal W/H	2,472.36	130.86	0.00
MC	2,614.11	37.90	37.90
SS	2,614.11	162.08	162.08
Unemployment	1,277.37	0.00	0.00
Total:	330.84	199.98	

DEDUCTIONS

Code	Subject To	Employee	Employer
400	2,834.88	141.75	122.75
530	0.00	230.77	0.00
540	0.00	34.23	0.00
551	0.00	40.00	0.00
580	0.00	3.06	0.00
590	0.00	158.75	649.92
615	0.00	22.02	0.00
Total:	630.58	772.67	

RECAP 3254 - JP Prec. 4

Earnings: 2,834.88 Benefits: 0.00 Deductions: 630.58 Taxes: 330.84 Net Pay: 1,873.46

Department: 4300 - County Sheriff

Total Direct Deposits: 54,841.41
 Total Check Amounts: 0.00

EARNINGS

Pay Code	Units	Pay Amount
112 - Holiday	264.00	5,136.82
165 Stipend w/RET	0.00	533.09
Hourly	2,562.50	49,630.80
LWP	85.50	1,558.37
OT	81.50	2,135.87
S	49.00	980.33
SAL	4.00	9,973.53
Uniform	0.00	875.00
Vacation	62.00	1,173.27
Total:	3,108.50	71,997.08

TAXES

Code	Subject To	Employee	Employer
Federal W/H	66,527.24	5,924.30	0.00
MC	70,227.10	1,018.30	1,018.30
SS	70,227.10	4,354.09	4,354.09
Unemployment	68,603.97	0.00	0.00
Total:		11,296.69	5,372.39

DEDUCTIONS

Code	Subject To	Employee	Employer
400	71,997.08	3,599.86	3,117.46
520	0.00	100.00	0.00
530	0.00	239.08	0.00
540	0.00	38.13	0.00
550	0.00	341.19	0.00
551	0.00	416.00	0.00
580	0.00	27.54	0.00
590	0.00	635.00	10,853.64
595	0.00	17.02	0.00
610	0.00	84.39	0.00
615	0.00	360.77	0.00
Total:		5,858.98	13,971.10

RECAP 4300 - County Sheriff

Earnings:	71,997.08	Benefits:	0.00	Deductions:	5,858.98	Taxes:	11,296.69	Net Pay:	54,841.41
-----------	-----------	-----------	------	-------------	----------	--------	-----------	----------	-----------

Department: 4310 - County Jail

Total Direct Deposits: 63,970.00
 Total Check Amounts: 3,452.46

EARNINGS

Pay Code	Units	Pay Amount
112 - Holiday	384.00	6,875.69
165 Stipend w/RET	0.00	295.00
Hourly	3,582.50	64,046.36
LWOP	80.00	0.00
OT	188.30	4,981.06
Payroll Accting Adj	1.00	-850.46
S	191.75	3,575.10
SAL	-29.00	5,329.97
Uniform	0.00	1,025.00
Vacation	155.75	2,975.91
Total:	4,554.30	88,253.63

TAXES

Code	Subject To	Employee	Employer
Federal W/H	81,796.72	7,206.42	0.00
MC	86,309.47	1,251.48	1,251.48
SS	86,309.47	5,351.14	5,351.14
Unemployment	87,874.93	0.00	0.00
Total:		13,809.04	6,602.62

DEDUCTIONS

Code	Subject To	Employee	Employer
400	88,253.63	4,412.75	3,821.37
520	0.00	100.00	0.00
530	0.00	323.54	0.00
550	0.00	378.70	0.00
551	0.00	237.55	0.00
580	0.00	19.89	0.00
590	0.00	793.75	15,313.08
595	0.00	42.48	0.00
610	0.00	42.76	0.00
615	0.00	491.68	0.00
620	0.00	179.03	0.00
Total:		7,022.13	19,134.45

RECAP 4310 - County Jail

Earnings: 88,253.63 Benefits: 0.00 Deductions: 7,022.13 Taxes: 13,809.04 Net Pay: 67,422.46

Department: 4321 - Constables-Pct. 1

Total Direct Deposits: 1,332.72
 Total Check Amounts: 0.00

EARNINGS

Pay Code	Units	Pay Amount
165 Stipend w/RET	0.00	16.15
Hourly	50.00	656.50
SAL	1.00	996.98
Total:	51.00	1,669.63

TAXES

Code	Subject To	Employee	Employer
Federal W/H	1,586.14	125.70	0.00
MC	1,669.63	24.21	24.21
SS	1,669.63	103.51	103.51
Unemployment	656.50	0.00	0.00
Total:		253.42	127.72

DEDUCTIONS

Code	Subject To	Employee	Employer
400	1,669.63	83.49	72.30
Total:		83.49	72.30

RECAP 4321 - Constables-Pct. 1

Earnings: 1,669.63 Benefits: 0.00 Deductions: 83.49 Taxes: 253.42 Net Pay: 1,332.72

Department: 4322 - Constables-Pct. 2

Total Direct Deposits: 1,459.68
 Total Check Amounts: 0.00

EARNINGS

Pay Code	Units	Pay Amount
165 Stipend w/RET	0.00	16.15
Hourly	94.00	1,234.22
SAL	1.00	996.98
Total:	95.00	2,247.35

TAXES

Code	Subject To	Employee	Employer
Federal W/H	2,009.21	387.22	0.00
MC	2,121.58	30.76	30.76
SS	2,121.58	131.55	131.55
Unemployment	2,233.73	0.00	0.00
Total:	549.53	549.53	162.31

DEDUCTIONS

Code	Subject To	Employee	Employer
400	2,247.35	112.37	97.31
550	0.00	13.62	0.00
551	0.00	96.00	0.00
590	0.00	0.00	317.46
615	0.00	16.15	0.00
Total:	238.14	238.14	414.77

RECAP 4322 - Constables-Pct. 2

Earnings: 2,247.35 Benefits: 0.00 Deductions: 238.14 Taxes: 549.53 Net Pay: 1,459.68

Department: 4323 - Constables-Pct. 3

Total Direct Deposits: 1,255.81
 Total Check Amounts: 0.00

EARNINGS

Pay Code	Units	Pay Amount
165 Stipend w/RET	0.00	16.15
Hourly	52.00	682.76
SAL	1.00	996.98
Total:	53.00	1,695.89

TAXES

Code	Subject To	Employee	Employer
Federal W/H	1,400.82	29.84	0.00
MC	1,485.62	21.53	21.53
SS	1,485.62	92.11	92.11
Unemployment	1,666.39	0.00	0.00
Total:	143.48	143.48	113.64

DEDUCTIONS

Code	Subject To	Employee	Employer
400	1,695.89	84.80	73.43
530	0.00	0.00	0.00
550	0.00	29.50	0.00
580	0.00	1.53	0.00
590	0.00	158.75	332.46
615	0.00	22.02	0.00
Total:	296.60	296.60	405.89

RECAP 4323 - Constables-Pct. 3

Earnings: 1,695.89 Benefits: 0.00 Deductions: 296.60 Taxes: 143.48 Net Pay: 1,255.81

Department: 4324 - Constables-Pct. 4

Total Direct Deposits: 1,414.92
 Total Check Amounts: 0.00

EARNINGS

Pay Code	Units	Pay Amount
165 Stipend w/RET	0.00	16.15
Hourly	83.00	1,089.79
SAL	1.00	996.98
Total:	84.00	2,102.92

TAXES

Code	Subject To	Employee	Employer
Federal W/H	1,707.34	149.17	0.00
MC	1,852.49	26.86	26.86
SS	1,852.49	114.86	114.86
Unemployment	1,089.79	0.00	0.00
Total:	1,707.34	290.89	141.72

DEDUCTIONS

Code	Subject To	Employee	Employer
400	2,102.92	105.15	91.06
520	0.00	40.00	0.00
550	0.00	18.92	0.00
551	0.00	45.00	0.00
580	0.00	1.53	0.00
590	0.00	158.75	332.46
595	0.00	5.74	0.00
615	0.00	22.02	0.00
Total:	2,102.92	397.11	423.52

RECAP 4324 - Constables-Pct. 4

Earnings: 2,102.92 Benefits: 0.00 Deductions: 397.11 Taxes: 290.89 Net Pay: 1,414.92

Department: 4330 - Driver's License

Total Direct Deposits: 445.85
 Total Check Amounts: 0.00

EARNINGS

Pay Code	Units	Pay Amount
Hourly	40.00	514.40
Total:	40.00	514.40

TAXES

Code	Subject To	Employee	Employer
Federal W/H	488.68	3.48	0.00
MC	514.40	7.46	7.46
SS	514.40	31.89	31.89
Unemployment	514.40	0.00	0.00
Total:	488.68	42.83	39.35

DEDUCTIONS

Code	Subject To	Employee	Employer
400	514.40	25.72	22.27
Total:	514.40	25.72	22.27

RECAP 4330 - Driver's License

Earnings: 514.40 Benefits: 0.00 Deductions: 25.72 Taxes: 42.83 Net Pay: 445.85

Department: 5401 - Juvenile Probation

Total Direct Deposits: 13,704.83
 Total Check Amounts: 0.00

EARNINGS

Pay Code	Units	Pay Amount
112 - Holiday	56.00	1,326.78
165 Stipend w/RET	0.00	129.20
FLOAT	8.00	160.81
Hourly	446.25	10,680.73
JP COMP TAKEN	7.00	156.56
S	24.00	629.45
SAL	-14.00	5,394.31
Vacation	34.75	866.97
Total:	562.00	19,344.81

BENEFITS

Pay Code	Units	Pay Amount
JP COMP EARNED	27.50	0.00
Total:	27.50	0.00

TAXES

Code	Subject To	Employee	Employer
Federal W/H	16,453.49	1,389.58	0.00
MC	17,665.74	256.15	256.15
SS	17,665.74	1,095.28	1,095.28
Unemployment	19,344.81	0.00	0.00
Total:	2,741.01	1,351.43	

DEDUCTIONS

Code	Subject To	Employee	Employer
400	19,344.81	967.25	837.63
520	0.00	245.00	0.00
551	0.00	536.00	0.00
552	0.00	376.00	0.00
580	0.00	7.65	0.00
590	0.00	650.26	2,584.68
595	0.00	2.86	0.00
615	0.00	113.95	0.00
Total:	2,898.97	3,422.31	

RECAP 5401 - Juvenile Probation

Earnings: 19,344.81 Benefits: 0.00 Deductions: 2,898.97 Taxes: 2,741.01 Net Pay: 13,704.83

Department: 6520 - Building Maintenance

Total Direct Deposits: 6,489.34
 Total Check Amounts: 0.00

EARNINGS

Pay Code	Units	Pay Amount
112 - Holiday	40.00	664.00
165 Stipend w/RET	0.00	48.45
FLOAT	8.00	171.27
Hourly	336.00	5,598.30
LWP	4.00	66.81
S	28.00	580.62
SAL	-71.00	171.27
Vacation	56.00	1,100.39
Total:	401.00	8,401.11

TAXES

Code	Subject To	Employee	Employer
Federal W/H	7,785.13	648.13	0.00
MC	8,205.18	118.97	118.97
SS	8,205.18	508.73	508.73
Unemployment	8,327.66	0.00	0.00
Total:	1,275.83	627.70	

DEDUCTIONS

Code	Subject To	Employee	Employer
400	8,401.11	420.05	363.78
550	0.00	73.45	0.00
551	0.00	90.00	0.00
580	0.00	6.12	0.00
590	0.00	0.00	1,904.76
595	0.00	8.58	0.00
610	0.00	13.84	0.00
615	0.00	23.90	0.00
Total:	635.94	2,268.54	

RECAP 6520 - Building Maintenance

Earnings: 8,401.11 Benefits: 0.00 Deductions: 635.94 Taxes: 1,275.83 Net Pay: 6,489.34

Department: 6550 - Elections

Total Direct Deposits: 2,344.01
 Total Check Amounts: 0.00

EARNINGS

Pay Code	Units	Pay Amount
112 - Holiday	8.00	124.79
Hourly	72.00	1,123.09
OT	20.00	311.97
SAL	1.00	1,746.92
Total:	101.00	3,306.77

TAXES

Code	Subject To	Employee	Employer
Federal W/H	2,699.95	108.90	0.00
MC	2,925.29	42.42	42.42
SS	2,925.29	181.37	181.37
Unemployment	3,286.00	0.00	0.00
Total:	332.69	332.69	223.79

DEDUCTIONS

Code	Subject To	Employee	Employer
400	3,306.77	165.34	143.18
520	0.00	60.00	0.00
550	0.00	20.77	0.00
551	0.00	112.00	0.00
580	0.00	3.06	0.00
590	0.00	158.75	649.92
595	0.00	8.31	0.00
610	0.00	20.19	0.00
615	0.00	81.65	0.00
Total:	630.07	793.10	

RECAP 6550 - Elections

Earnings:	3,306.77	Benefits:	0.00	Deductions:	630.07	Taxes:	332.69	Net Pay:	2,344.01
-----------	----------	-----------	------	-------------	--------	--------	--------	----------	----------

Department: 6560 - Commissioners Court

Total Direct Deposits: 7,609.42
 Total Check Amounts: 0.00

EARNINGS

Pay Code	Units	Pay Amount
112 - Holiday	8.00	167.52
165 Stipend w/RET	0.00	212.51
Hourly	72.00	1,507.64
SAL	5.00	8,733.73
Total:	85.00	10,621.40

TAXES

Code	Subject To	Employee	Employer
Federal W/H	9,015.48	671.17	0.00
MC	9,546.54	138.42	138.42
SS	9,546.54	591.88	591.88
Unemployment	8,867.24	0.00	0.00
Total:	1,401.47	1,401.47	730.30

DEDUCTIONS

Code	Subject To	Employee	Employer
400	10,621.40	531.06	459.92
550	0.00	54.47	0.00
551	0.00	96.00	0.00
580	0.00	4.59	0.00
590	0.00	824.27	1,949.76
595	0.00	11.19	0.00
615	0.00	88.93	0.00
Total:	1,610.51	2,409.68	

RECAP 6560 - Commissioners Court

Earnings:	10,621.40	Benefits:	0.00	Deductions:	1,610.51	Taxes:	1,401.47	Net Pay:	7,609.42
-----------	-----------	-----------	------	-------------	----------	--------	----------	----------	----------

Department: 6570 - Veteran Service Officer

Total Direct Deposits: 1,008.62
 Total Check Amounts: 0.00

EARNINGS

Pay Code	Units	Pay Amount
165 Stipend w/RET	0.00	16.15
SAL	1.00	1,292.30
Total:	1.00	1,308.45

TAXES

Code	Subject To	Employee	Employer
Federal W/H	1,213.26	106.82	0.00
MC	1,278.68	18.54	18.54
SS	1,278.68	79.28	79.28
Unemployment	1,294.83	0.00	0.00
Total:		204.64	97.82

DEDUCTIONS

Code	Subject To	Employee	Employer
400	1,308.45	65.42	56.66
550	0.00	13.62	0.00
590	0.00	0.00	317.46
615	0.00	16.15	0.00
Total:		95.19	374.12

RECAP 6570 - Veteran Service Officer

Earnings: 1,308.45 Benefits: 0.00 Deductions: 95.19 Taxes: 204.64 Net Pay: 1,008.62

Department: 6580 - Human Resources

Total Direct Deposits: 990.91
 Total Check Amounts: 0.00

EARNINGS

Pay Code	Units	Pay Amount
SAL	1.00	1,663.85
Total:	1.00	1,663.85

TAXES

Code	Subject To	Employee	Employer
Federal W/H	1,559.29	442.73	0.00
MC	1,642.48	23.82	23.82
SS	1,642.48	101.83	101.83
Unemployment	1,650.23	0.00	0.00
Total:		568.38	125.65

DEDUCTIONS

Code	Subject To	Employee	Employer
400	1,663.85	83.19	72.04
550	0.00	13.62	0.00
615	0.00	7.75	0.00
Total:		104.56	72.04

RECAP 6580 - Human Resources

Earnings: 1,663.85 Benefits: 0.00 Deductions: 104.56 Taxes: 568.38 Net Pay: 990.91

Department: 6590 - Purchasing

Total Direct Deposits: 1,423.49
 Total Check Amounts: 0.00

EARNINGS

Pay Code	Units	Pay Amount
165 Stipend w/RET	0.00	16.15
SAL	-7.00	1,661.53
Vacation	8.00	184.62
Total:	1.00	1,862.30

TAXES

Code	Subject To	Employee	Employer
Federal W/H	1,761.43	196.07	0.00
MC	1,854.55	26.89	26.89
SS	1,854.55	114.98	114.98
Unemployment	1,862.30	0.00	0.00
Total:		337.94	141.87

DEDUCTIONS

Code	Subject To	Employee	Employer
400	1,862.30	93.12	80.64
590	0.00	0.00	317.46
615	0.00	7.75	0.00
Total:		100.87	398.10

RECAP 6590 - Purchasing

Earnings: 1,862.30 Benefits: 0.00 Deductions: 100.87 Taxes: 337.94 Net Pay: 1,423.49

Department: 6610 - IT-Technology

Total Direct Deposits: 3,323.27
 Total Check Amounts: 0.00

EARNINGS

Pay Code	Units	Pay Amount
112 - Holiday	8.00	177.79
165 Stipend w/RET	0.00	69.24
Hourly	72.00	1,600.12
S	16.00	545.94
SAL	-15.00	2,183.73
Total:	81.00	4,576.82

TAXES

Code	Subject To	Employee	Employer
Federal W/H	4,051.67	382.58	0.00
MC	4,480.51	64.97	64.97
SS	4,480.51	277.79	277.79
Unemployment	4,532.71	0.00	0.00
Total:		725.34	342.76

DEDUCTIONS

Code	Subject To	Employee	Employer
400	4,576.82	228.84	198.17
520	0.00	200.00	0.00
550	0.00	44.11	0.00
551	0.00	36.00	0.00
580	0.00	3.06	0.00
590	0.00	0.00	634.92
615	0.00	16.20	0.00
Total:		528.21	833.09

RECAP 6610 - IT-Technology

Earnings: 4,576.82 Benefits: 0.00 Deductions: 528.21 Taxes: 725.34 Net Pay: 3,323.27

Department: 6630 - Grant Writing

Total Direct Deposits: 1,727.05
 Total Check Amounts: 0.00

EARNINGS

Pay Code	Units	Pay Amount
165 Stipend w/RET	0.00	16.15
FLOAT	8.00	211.54
SAL	-7.00	1,903.84
Total:	1.00	2,131.53

TAXES

Code	Subject To	Employee	Employer
Federal W/H	2,024.95	134.84	0.00
MC	2,131.53	30.91	30.91
SS	2,131.53	132.15	132.15
Unemployment	2,131.53	0.00	0.00
Total:		297.90	163.06

DEDUCTIONS

Code	Subject To	Employee	Employer
400	2,131.53	106.58	92.30
Total:		106.58	92.30

RECAP 6630 - Grant Writing

Earnings: 2,131.53 Benefits: 0.00 Deductions: 106.58 Taxes: 297.90 Net Pay: 1,727.05

Department: 6640 - Code Investigator

Total Direct Deposits: 1,265.65
 Total Check Amounts: 0.00

EARNINGS

Pay Code	Units	Pay Amount
112 - Holiday	8.00	153.81
165 Stipend w/RET	0.00	34.62
Hourly	72.00	1,384.29
Total:	80.00	1,572.72

TAXES

Code	Subject To	Employee	Employer
Federal W/H	1,474.08	88.12	0.00
MC	1,552.72	22.51	22.51
SS	1,552.72	96.27	96.27
Unemployment	1,572.72	0.00	0.00
Total:		206.90	118.78

DEDUCTIONS

Code	Subject To	Employee	Employer
400	1,572.72	78.64	68.10
551	0.00	20.00	0.00
580	0.00	1.53	0.00
590	0.00	0.00	317.46
Total:		100.17	385.56

RECAP 6640 - Code Investigator

Earnings: 1,572.72 Benefits: 0.00 Deductions: 100.17 Taxes: 206.90 Net Pay: 1,265.65

Department: 6650 - Emerg Mgnt/Homeland Sec

Total Direct Deposits: 2,766.91
 Total Check Amounts: 0.00

EARNINGS

Pay Code	Units	Pay Amount
112 - Holiday	8.00	156.99
165 Stipend w/RET	0.00	69.24
Hourly	72.00	1,412.93
SAL	1.00	2,170.57
Total:	81.00	3,809.73

TAXES

Code	Subject To	Employee	Employer
Federal W/H	3,389.24	337.00	0.00
MC	3,729.73	54.09	54.09
SS	3,729.73	231.24	231.24
Unemployment	3,767.75	0.00	0.00
Total:		622.33	285.33

DEDUCTIONS

Code	Subject To	Employee	Employer
400	3,809.73	190.49	164.96
520	0.00	150.00	0.00
550	0.00	41.98	0.00
590	0.00	0.00	634.92
595	0.00	5.72	0.00
615	0.00	32.30	0.00
Total:		420.49	799.88

RECAP 6650 - Emerg Mgnt/Homeland Sec

Earnings: 3,809.73 Benefits: 0.00 Deductions: 420.49 Taxes: 622.33 Net Pay: 2,766.91

Department: 7610 - Sanitation Department

Total Direct Deposits: 0.00
 Total Check Amounts: 1,599.14

EARNINGS

Pay Code	Units	Pay Amount
112 - Holiday	8.00	190.44
165 Stipend w/RET	0.00	34.62
Hourly	72.00	1,713.92
Total:	80.00	1,938.98

TAXES

Code	Subject To	Employee	Employer
Federal W/H	1,842.03	40.97	0.00
MC	1,938.98	28.12	28.12
SS	1,938.98	120.22	120.22
Unemployment	1,938.98	0.00	0.00
Total:	1,938.98	189.31	148.34

DEDUCTIONS

Code	Subject To	Employee	Employer
400	1,938.98	96.95	83.96
540	0.00	52.05	0.00
580	0.00	1.53	0.00
590	0.00	0.00	317.46
Total:	1,938.98	150.53	401.42

RECAP 7610 - Sanitation Department

Earnings: 1,938.98 Benefits: 0.00 Deductions: 150.53 Taxes: 189.31 Net Pay: 1,599.14

Department: 8700 - County Agent

Total Direct Deposits: 3,790.82
 Total Check Amounts: 0.00

EARNINGS

Pay Code	Units	Pay Amount
112 - Holiday	8.00	134.81
Hourly	72.00	1,213.25
SAL	-5.00	3,196.38
Vacation	8.00	157.69
Total:	83.00	4,702.13

TAXES

Code	Subject To	Employee	Employer
Federal W/H	4,536.87	386.27	0.00
MC	4,683.12	67.90	67.90
SS	4,683.12	290.35	290.35
Unemployment	4,702.13	0.00	0.00
Total:	4,702.13	744.52	358.25

DEDUCTIONS

Code	Subject To	Employee	Employer
400	2,924.98	146.25	126.65
580	0.00	1.53	0.00
590	0.00	0.00	634.92
595	0.00	2.86	0.00
615	0.00	16.15	0.00
Total:	2,924.98	166.79	761.57

RECAP 8700 - County Agent

Earnings: 4,702.13 Benefits: 0.00 Deductions: 166.79 Taxes: 744.52 Net Pay: 3,790.82



Caldwell County, TX

Detail Register

Payroll Summary

Packet: PYPKT01291 - 041419 thru 042719 Payroll Pay Date 050319
 Payroll Set: 01 - Payroll Set 01

Pay Period: 04/14/2019 - 04/27/2019

Total Direct Deposits: 280,416.86
 Total Check Amounts: 11,171.48

Males Paid: 130
 Females Paid: 115
 Total Employees: 245

EARNINGS

Pay Code	Units	Pay Amount
112 - Holiday	1,400.00	25,599.79
165 Stipend w/RET	0.00	1,702.84
BEREAVEMENT	24.00	484.98
DA Supplement	0.00	151.67
FLOAT	48.00	1,075.21
HOL	8.00	124.00
Hourly	12,933.40	234,168.42
JP COMP TAKEN	7.00	156.56
Jud Stip	0.00	3,230.77
Longevity w/RET	0.00	204.62
LWOP	80.00	0.00
LWP	89.50	1,625.18
OT	295.80	7,598.60
Payroll Accting Adj	1.00	-850.46
S	470.50	9,999.71
SAL	-210.00	90,857.83
Uniform	0.00	2,100.00
Vacation	555.60	11,272.09
Total:	15,702.80	389,501.81

BENEFITS

Pay Code	Units	Pay Amount
JP COMP EARNED	27.50	0.00
Total:	27.50	0.00

TAXES

Code	Subject To	Employee	Employer
Federal W/H	353,455.29	30,871.82	0.00
MC	374,676.62	5,432.83	5,432.83
SS	374,676.62	23,229.97	23,229.97
Unemployment	373,935.27	0.00	0.00
Total:	59,534.62	28,662.80	

PIR Tax: 88,197.42

DEDUCTIONS

Code	Subject To	Employee	Employer
400	387,724.66	19,386.33	16,788.50
520	0.00	1,835.00	0.00
530	0.00	793.39	0.00
540	0.00	165.46	0.00
550	0.00	1,802.43	0.00
551	0.00	2,984.55	0.00
552	0.00	476.00	0.00
560	0.00	75.00	0.00
580	0.00	153.00	0.00
590	0.00	7,106.88	64,349.46
595	0.00	200.99	0.00
610	0.00	218.64	0.00
615	0.00	2,254.34	0.00
620	0.00	397.75	0.00
Bankruptcy	0.00	529.09	0.00
Total:	38,378.85	81,137.96	

RECAP 01 - Payroll Set 01

Earnings:	389,501.81	Benefits:	0.00	Deductions:	38,378.85	Taxes:	59,534.62	Net Pay:	291,588.34 ✓
-----------	------------	-----------	------	-------------	-----------	--------	-----------	----------	--------------

D. \$88,197.42 (Payroll Tax for 4/14/19 – 4/27/19); Backup: 2

Caldwell County Agenda Item Request Form

To: All Elected Officials and Department Heads – Hand deliver or scan & email to hoppy.haden@co.caldwell.tx.us and ezzy.chan@co.caldwell.tx.us . Deadline is 5:00 pm Tuesday before the Regular meetings, however, please submit this completed form ASAP. "Anything missing will cause the Agenda Item to be held over to the next Regular meeting," according to our Rules & Procedures.

AGENDA DATE: 5/13/2019

Type of Agenda Item

- Consent Discussion/Action Executive Session Workshop
 Public Hearing

What will be discussed? What is the proposed motion?

to accept the 4/14/19 - 4/27/19 Payroll Tax in the amount of \$88,197.42

1. **Costs:**

Actual Cost or Estimated Cost \$ _____

Is this cost included in the County Budget? _____

Is a Budget Amendment being proposed? _____

2. **Agenda Speakers:**

Name	Representing	Title

(1) _____

(2) _____

(3) _____

3. **Backup Materials:**

None To Be Distributed 2 total # of backup pages
(including this page)

4.  _____
Signature of Court Member

_____ 5/7/2019 _____
Date



Caldwell County, TX

Detail Register Payroll Summary

Packet: PYPKT01291 - 041419 thru 042719 Payroll Pay Date 050319
Payroll Set: 01 - Payroll Set 01

Pay Period: 04/14/2019 - 04/27/2019

Total Direct Deposits: 280,416.86
Total Check Amounts: 11,171.48

Males Paid: 130
Females Paid: 115
Total Employees: 245

EARNINGS

Pay Code	Units	Pay Amount
112 - Holiday	1,400.00	25,599.79
165 Stipend w/RET	0.00	1,702.84
BEREAVEMENT	24.00	484.98
DA Supplement	0.00	151.67
FLOAT	48.00	1,075.21
HOL	8.00	124.00
Hourly	12,933.40	234,168.42
JP COMP TAKEN	7.00	156.56
Jud Stip	0.00	3,230.77
Longevity w/RET	0.00	204.62
LWOP	80.00	0.00
LWP	89.50	1,625.18
OT	295.80	7,598.60
Payroll Accting Adj	1.00	-850.46
S	470.50	9,999.71
SAL	-210.00	90,857.83
Uniform	0.00	2,100.00
Vacation	555.60	11,272.09
Total:	15,702.80	389,501.81

BENEFITS

Pay Code	Units	Pay Amount
JP COMP EARNED	27.50	0.00
Total:	27.50	0.00

TAXES

Code	Subject To	Employee	Employer
Federal W/H	353,455.29	30,871.82	0.00
MC	374,676.62	5,432.83	5,432.83
SS	374,676.62	23,229.97	23,229.97
Unemployment	373,935.27	0.00	0.00
Total:		59,534.62	28,662.80

P/R Tax: 88,197.42

DEDUCTIONS

Code	Subject To	Employee	Employer
400	387,724.66	19,386.33	16,788.50
520	0.00	1,835.00	0.00
530	0.00	793.39	0.00
540	0.00	165.46	0.00
550	0.00	1,802.43	0.00
551	0.00	2,984.55	0.00
552	0.00	476.00	0.00
560	0.00	75.00	0.00
580	0.00	153.00	0.00
590	0.00	7,106.88	64,349.46
595	0.00	200.99	0.00
610	0.00	218.64	0.00
615	0.00	2,254.34	0.00
620	0.00	397.75	0.00
Bankruptcy	0.00	529.09	0.00
Total:		38,378.85	81,137.96

RECAP 01 - Payroll Set 01

Earnings:	389,501.81	Benefits:	0.00	Deductions:	38,378.85	Taxes:	59,534.62	Net Pay:	291,588.34
-----------	------------	-----------	------	-------------	-----------	--------	-----------	----------	-------------------

E. \$259,738.13 (Department of Motor Vehicle Fees-March 2019); Backup: 2

Caldwell County Agenda Item Request Form

To: All Elected Officials and Department Heads – Hand deliver or scan & email to hoppy.haden@co.caldwell.tx.us and ezzy.chan@co.caldwell.tx.us . Deadline is 5:00 pm Tuesday before the Regular meetings, however, please submit this completed form ASAP. "Anything missing will cause the Agenda Item to be held over to the next Regular meeting," according to our Rules & Procedures.

AGENDA DATE: 5/13/2019

Type of Agenda Item

- Consent Discussion/Action Executive Session Workshop
 Public Hearing

What will be discussed? What is the proposed motion?

to ratify re-occurring County Payments of \$259,738.13 to Department of Motor Vehicle Fees

1. Costs:

Actual Cost or Estimated Cost \$ 259,738.13

Is this cost included in the County Budget? yes

Is a Budget Amendment being proposed? no

2. Agenda Speakers:

Name	Representing	Title
------	--------------	-------

(1) _____

(2) _____

(3) _____

3. Backup Materials: None To Be Distributed 2 total # of backup pages (including this page)

4. 
Signature of Court Member

5/7/2019
Date



259,738.13

RTS: County Funds Remittance - Internet Explorer

https://rts1.tx... | RTS: County F... | TxDMV.GOV - RT... | Tax Assessor-Col...

Texas Department of Motor Vehicles
REGISTRATION & TITLE SYSTEM

Customer Miscellaneous Reports Local Options Accounting Inventory Funds Exit Help

Funds Due Summary ACC017

Select a report using arrow keys and press enter.

Due Date	Funds Report Date	Reporting Date	Total Amount Due	Remittance Amount
03/27/2019	03/25/2019	03/25/2019	428.00	0.00
03/26/2019	03/26/2019	03/26/2019	272.00	0.00
03/20/2019	03/27/2019	03/27/2019	602.00	0.00
04/01/2019	03/28/2019	03/28/2019	220.00	0.00
04/02/2019	03/29/2019	03/29/2019	389.00	0.00
04/02/2019	03/30/2019	03/30/2019	94789.33	0.00
Totals:			259738.13	0.00

Enter Cancel

USER: 025-CLARK, CALDWELL COUNTY, CALDWELL COUNTY, TX
POS Version 9.20 (12-11-2013)

8:35 AM
4/22/2019

F. \$405,060.49 (Department of Motor Vehicles Comptroller); Backup: 14

Caldwell County Agenda Item Request Form

To: All Elected Officials and Department Heads – Hand deliver or scan & email to hoppy.haden@co.caldwell.tx.us and ezzy.chan@co.caldwell.tx.us . Deadline is 5:00 pm Tuesday before the Regular meetings, however, please submit this completed form ASAP. "Anything missing will cause the Agenda Item to be held over to the next Regular meeting," according to our Rules & Procedures.

AGENDA DATE: 5/13/2019

Type of Agenda Item

- Consent Discussion/Action Executive Session Workshop
 Public Hearing

What will be discussed? What is the proposed motion?

to accept payments to Department of Motor Vehicles/Comptroller in the amount of \$405,060.49

1. Costs:

Actual Cost or Estimated Cost \$ 405,060.49

Is this cost included in the County Budget? yes

Is a Budget Amendment being proposed? NO

2. Agenda Speakers:

Name	Representing	Title
------	--------------	-------

(1) _____

(2) _____

(3) _____

3. Backup Materials: None To Be Distributed 14 total # of backup pages (including this page)

4.  _____
Signature of Court Member

Date 5/7/2019

b.



Texas Motor Vehicle Sales/Use Tax and Surcharge Report

a. 17100

* Do not write in shaded areas.

c. Taxpayer number
 32049986444

d. Filing period
Month Ending 04/30/2019

e.

f. Due date
05/10/2019

g. Name and mailing address (Make any necessary name or address changes below.)

The Honorable Darla Law (Caldwell County TAC)
110 S Main St Room 101
Lockhart, Texas

h. IMPORTANT

Blacken this box if your mailing address has changed. Show changes by the preprinted information.

i.

j.

You have certain rights under Chapters 552 and 559, Government Code, to review, request and correct information we have on file about you. Contact us at the address or phone number listed on this form.

1. Number of receipts issued (Including Voids) _____
2. Gross Motor Vehicle Sales and Use Tax collected (Dollars & cents) _____
3. 2.5% Surcharge collected for model years 1996 and prior (Dollars & cents) _____
4. 1.0% Surcharge collected for model years 1997 and later (Dollars & cents) _____
5. Gross Surcharge collected (Item 3B plus Item 4B) _____
6. Claim for dishonored payment _____
7. Commission not available from registration fees _____
8. Commission available from Sales Tax/TERP Surcharge _____
9. Net motor vehicle tax and/or surcharge collected (Item 2A minus Items 6A, 7A, and 8A; Item 5B minus Items 6B, 7B and 8B) _____
10. Interest earned _____
11. TOTAL AMOUNT DUE (Item 9A plus Item 10A and Item 9B plus Item 10B) _____

14100 COL. I TAX CALCULATION		17100 COL. II SURCHARGE CALCULATION	
1A. <input type="checkbox"/>	1052	1B. <input type="checkbox"/>	5
2A. <input type="checkbox"/>	380,967.74	2B. <input type="checkbox"/>	
3A. <input type="checkbox"/>		3B. <input type="checkbox"/>	2,381.92
4A. <input type="checkbox"/>		4B. <input type="checkbox"/>	
5A. <input type="checkbox"/>		5B. <input type="checkbox"/>	
6A. <input type="checkbox"/>		6B. <input type="checkbox"/>	
7A. <input type="checkbox"/>		7B. <input type="checkbox"/>	
8A. <input type="checkbox"/>		8B. <input type="checkbox"/>	
9A. <input type="checkbox"/>		9B. <input type="checkbox"/>	
10A. <input type="checkbox"/>		10B. <input type="checkbox"/>	
11A. <input type="checkbox"/>		11B. <input type="checkbox"/>	
12A. <input type="checkbox"/>		12B. <input type="checkbox"/>	
13A. <input type="checkbox"/>	380,967.74	13B. <input type="checkbox"/>	2,381.92
k. <input type="checkbox"/>		l. <input type="checkbox"/>	
14. TOTAL AMOUNT OF TAX AND SURCHARGE DUE AND PAYABLE (Item 13A plus Item 13B)		14. 383,349.66	

14-115 (Rev. 11-18/10)

12. Total amount of prepayments _____

13. Amount due (Item 11A minus Item 12A and Item 11B minus 12B) _____

14. TOTAL AMOUNT OF TAX AND SURCHARGE DUE AND PAYABLE (Item 13A plus Item 13B) _____

Taxpayer name: The Honorable Darla Law (Caldwell County TAC) m.

T Code Taxpayer number Period
17920 32049986444

Make the amount in Item 14 payable to STATE COMPTROLLER
Mail to: COMPTROLLER OF PUBLIC ACCOUNTS
P.O. Box 149360
Austin, Texas 78714-9360

I declare that the information in this document and any attachments is true and correct to the best of my knowledge and belief.

Duly authorized agent (PLEASE PRINT NAME)

Darla Law

sign here

Business phone 512-398-1830

Date 05/06/2019

If you have any questions regarding Motor Vehicle Sales and Use Tax or Surcharge, call 1-800-252-1382.

Texas Motor Vehicle Registration Surcharge and/or Title Application Fee Report



a T Code 21100

c. Taxpayer number <input checked="" type="checkbox"/> 32049986444	d. Filing period Month Ending 04/30/2019	e. <input type="checkbox"/>	f. Due date 05/10/2019
-----------------------------------------------------------------------	---------------------------------------------	-----------------------------	---------------------------

g. Name and mailing address (Make any necessary name or address changes below.)

The Honorable Darla Law (Caldwell County TAC)
110 S Main St Room 101
Lockhart, Texas 78644

h. **IMPORTANT**

Blacken this box if your mailing address has changed. Show changes by the preprinted information. → 1.

Blacken this box if you are no longer in office and write in the date you left office. → 2.

Month Day Year

I. J.

Who Must File

Texas County Tax Assessor-Collectors (TACs) must file this report with the Comptroller's office on a monthly basis.

Due Date

The report is due by the 10th day of the month after the reporting period.

Column B - Title Application Fee/Texas Mobility Fund Instructions

Non-attainment counties must remit \$20.00 of each title application fee to the Comptroller's office for the the Texas Mobility Fund. All other counties must remit \$15.00 of each title application fee for the fund.

*** Do not write in shaded areas.***

	21100 COLUMN A Registration Surcharge	12100 COLUMN B Title Application Fee/Texas Mobility Fund
1. Number of registrations and/or title applications (Include any collections made on previous dishonored payments)	1a. <input checked="" type="checkbox"/> 39	1b. <input checked="" type="checkbox"/> 960
2. Total registration surcharge and/or title application fees collected	2a. <input checked="" type="checkbox"/> \$ 2,850.83	2b. <input checked="" type="checkbox"/> \$ 18,860.00
3. Claim for dishonored payment	3a. <input checked="" type="checkbox"/> \$	3b. <input checked="" type="checkbox"/> \$
4. Total surcharge and/or title application fee due (Item 2 minus Item 3)	4a. <input checked="" type="checkbox"/> \$ 2,850.83	4b. <input checked="" type="checkbox"/> \$ 18,860.00
*** DO NOT DETACH ***		
5. Prior payments (Include electronic funds submitted for this reporting period)	5a. <input checked="" type="checkbox"/> \$	5b. <input checked="" type="checkbox"/> \$
6. Total amount due and payable (Item 4 minus Item 5)	6a. <input checked="" type="checkbox"/> \$ 2,850.83	6b. <input checked="" type="checkbox"/> \$ 18,860.00
7. TOTAL AMOUNT OF MOTOR VEHICLE SURCHARGE AND/OR TITLE APPLICATION FEE DUE AND PAYABLE (Add Item 6a and Item 6b)	k. <input checked="" type="checkbox"/>	7. <input checked="" type="checkbox"/> \$ 21,710.83

Taxpayer name **The Honorable Darla Law (Caldwell County TAC)** I.

T Code Taxpayer number Period
21920 32049986444

Make check payable to STATE COMPTROLLER
Mail to COMPTROLLER OF PUBLIC ACCOUNTS
P.O. Box 149360
Austin, Texas 78714-9360

I declare that the information in this document and any attachments is true and correct to the best of my knowledge and belief.

sign here → Taxpayer or duly authorized agent

Business phone 512-398-1830 Date



Texas Department of Motor Vehicles

Texas Department of Motor Vehicles

RTS.FIN.009

MONTHLY FUNDS REPORT

For: April 2019

Registration and Title System Report

Transaction Year: 2019 Transaction Month: April Account Item Code: REGISTRATION EMISSIONS FEE, SALES TAX FEE, SALES TAX EMISSIONS FEE, SALES TAX EMISSION FEE 1%, SALES TAX PENALTY FEE, TERP FEE, TEXAS MOBILITY FUND FEE, YOUNG FARMER PROGRAM Office: 028 - CALDWELL

Monthly Totals table with columns: County, REGISTRATION EMISSIONS FEE, SALES TAX EMISSION FEE 1%, SALES TAX FEE, SALES TAX PENALTY FEE, TEXAS MOBILITY FUND FEE, YOUNG FARMER PROGRAM. Row for 028 - CALDWELL.

County: 028 - CALDWELL Total Item Price: \$2,850.83

Account Item Code Description: REGISTRATION EMISSIONS FEE

Items sold: 38

Voided: 1

Table listing item details for REGISTRATION EMISSIONS FEE with columns: Item ID, Price, Description, Amount, Item ID, Price, Description, Amount, Item ID, Price, Description, Amount.

County: 028 - CALDWELL Total Item Price: \$2,381.92

Account Item Code Description: SALES TAX EMISSION FEE 1%

Items sold: 5

Voided: 0

Table listing item details for SALES TAX EMISSION FEE 1% with columns: Item ID, Price, Description, Amount, Item ID, Price, Description, Amount.



Texas Department of Motor Vehicles

Texas Department of Motor Vehicles

RTS.FIN.009

MONTHLY FUNDS REPORT

For: April 2019

Registration and Titling Report

Transaction Year: 2019 Transaction Month: April Account Item Code: REGISTRATION EMISSIONS FEE, SALES TAX FEE, SALES TAX EMISSIONS FEE, SALES TAX EMISSION FEE 1%, SALES TAX PENALTY FEE, TERP FEE, TEXAS MOBILITY FUND FEE, YOUNG FARMER PROGRAM

Office: 028 - CALDWELL

County: 028 - CALDWELL Total Item Price: \$378,305.25

Account Item Code Description: SALES TAX FEE Items sold: 942

Voided: 12

Table with 8 columns: Item ID, Amount, Item ID, Amount, Item ID, Amount, Item ID, Amount. Lists various transaction items and their corresponding amounts.

Run Date: 05/06/2019 Run Time: 8:40:08 AM

Page 2 of 11

RTS Date: 05/03/2019



MONTHLY FUNDS REPORT

For: April 2019

Transaction Year: 2019 Transaction Month: April Account Item Code: REGISTRATION EMISSIONS FEE, SALES TAX FEE, SALES TAX EMISSIONS FEE, SALES TAX EMISSION FEE 1%, SALES TAX PENALTY FEE, TERP FEE, TEXAS MOBILITY FUND FEE, YOUNG FARMER PROGRAM

Office: 028 - CALDWELL

County: 028 - CALDWELL Total Item Price: \$378,205.25

Account Item Code Description: SALES TAX FEE Items sold: 942

Voided: 12

Table with 8 columns: Item ID, Amount, Item ID, Amount, Item ID, Amount, Item ID, Amount. Lists 942 transactions for SALES TAX FEE.



Texas Department of Motor Vehicles

Texas Department of Motor Vehicles

RTS FIN 009

MONTHLY FUNDS REPORT

For: April 2019

REGISTRATION AND EMPLOYMENT REPORT

Transaction Year: 2019 Transaction Month: April Account Item Code: REGISTRATION EMISSIONS FEE, SALES TAX FEE, SALES TAX EMISSIONS FEE, SALES TAX EMISSION FEE 1%, SALES TAX PENALTY FEE, TERP FEE, TEXAS MOBILITY FUND FEE, YOUNG FARMER PROGRAM Office: 028 - CALDWELL

County: 028 - CALDWELL Total Item Price: \$378,305.25

Account Item Code Description: SALES TAX FEE Items sold: 942

Voided: 12

Table with 8 columns: Item ID, Amount, Item ID, Amount, Item ID, Amount, Item ID, Amount. Lists various transaction items and their corresponding amounts.

Run Date: 05/06/2019 Run Time: 8:40:08 AM

Page 4 of 11

RTS Date: 05/03/2019



Texas Department of Motor Vehicles

Texas Department of Motor Vehicles

RTS.FIN.009

MONTHLY FUNDS REPORT

For: April 2019

Registration and Title System Report

Transaction Year: 2019

Transaction Month: April

Account Item Code: REGISTRATION EMISSIONS FEE, SALES TAX FEE, SALES TAX EMISSIONS FEE, SALES TAX EMISSION FEE 1%, SALES TAX PENALTY FEE, TERP FEE, TEXAS MOBILITY FUND FEE, YOUNG FARMER PROGRAM

Office: 028 - CALDWELL

County: 028 - CALDWELL
Total Item Price: \$378,305.25

Account Item Code Description: SALES TAX FEE
Items sold: 942

Voided: 12

Table with 8 columns: Item ID, Amount, Item ID, Amount, Item ID, Amount, Item ID, Amount. Lists various transaction items and their corresponding amounts.

Run Date: 05/06/2019
Run Time: 8:40:08 AM

RTS Date: 05/03/2019



Texas Department of Motor Vehicles

Texas Department of Motor Vehicles

RTS.FIN.009

MONTHLY FUNDS REPORT

For: April 2019

Registration and Title System Report

Transaction Year: 2019

Transaction Month: April

Account Item Code: REGISTRATION EMISSIONS FEE, SALES TAX FEE, SALES TAX EMISSIONS FEE, SALES TAX EMISSION FEE 1%, SALES TAX PENALTY FEE, TERP FEE, TEXAS MOBILITY FUND FEE, YOUNG FARMER PROGRAM

Office: 028 - CALDWELL

County: 028 - CALDWELL
Total Item Price: \$2,662.49

Account Item Code Description: SALES TAX PENALTY FEE

Items sold: 98

Voided: 0

02810043554123924	\$1.00	02810043571250001	\$1.22	02800043561144331	\$1.25	02810043579144224	\$1.56
02810043557131648	\$1.69	02810043568152251	\$1.88	02810043576135058	\$1.88	02825043575104331	\$2.50
02800143578100032	\$2.63	02800143582102647	\$3.13	02825043555154604	\$3.13	02800143579145100	\$3.50
02800043558095036	\$3.75	02820043575115144	\$4.06	02825043556154502	\$4.06	02810043575112633	\$4.22
02810043555100949	\$4.32	02810043575105048	\$4.69	02800143563134210	\$4.88	02800143557160115	\$5.00
02810043571154430	\$5.00	02820043558160602	\$5.06	02800043564085142	\$5.13	02820043565153028	\$5.78
02800043556123015	\$6.25	02810043555103249	\$6.25	02810043563153339	\$6.25	02825043558144205	\$6.25
02825043563085928	\$6.25	02800043564142639	\$6.38	02800143570153149	\$6.50	02800043577140427	\$6.88
02800143575131618	\$6.88	02800043568142615	\$7.13	02810043561130946	\$7.34	02825043556102025	\$7.81
02820043555104832	\$8.12	02825043575105033	\$8.75	02800043565142136	\$9.38	02800043569114654	\$9.38
02825043558151331	\$9.69	02800043558161544	\$10.00	02820043562145146	\$10.63	02810043575114546	\$12.47
02810043576104533	\$12.50	02810043578114942	\$15.63	02820043558131722	\$15.63	02810043571250002	\$16.49
02820043568134708	\$17.19	02820043577082649	\$18.13	02820043583142327	\$18.73	02800043575153646	\$18.75
02825043575124008	\$20.00	02810043575110101	\$20.16	02800043575160450	\$21.88	02810043575121629	\$21.88
02810043583111757	\$21.88	02810043555144957	\$23.13	02810043579250006	\$23.43	02810043579250010	\$23.53
02820043558151749	\$23.75	02820043561151201	\$23.75	02810043575114019	\$24.84	02825043570142457	\$24.84
02810043554095141	\$27.13	02825043570142030	\$27.48	02810043579250005	\$28.05	02820043583141456	\$29.69
02810043579250001	\$30.42	02800043579085814	\$30.50	02810043554161423	\$35.00	02810043575114306	\$37.19
02820043583142729	\$37.19	02810043571250003	\$37.49	02825843565114059	\$37.50	02810043571250013	\$38.74
02810043579250004	\$40.20	02810043578131823	\$43.20	02810043571250004	\$44.39	02810043554094550	\$45.53
02810043579250003	\$46.55	02800043570100630	\$47.80	02810043570151080	\$50.00	02820043583141212	\$50.00
02800143582135854	\$50.75	02810043582122811	\$52.88	02825043575113006	\$59.50	02810043583162206	\$62.50
02820043564102500	\$66.64	02810043556095321	\$71.24	02800043562100652	\$81.25	02810043565142722	\$84.50
02810043579250002	\$90.62	02810043571094837	\$106.25	02800043565151247	\$112.50	02810043575110618	\$116.72
02820043571092842	\$140.81	02810043568130904	\$156.25				



Texas Department of Motor Vehicles

Texas Department of Motor Vehicles

RTS.FIN.009

MONTHLY FUNDS REPORT

For April 2019

Registration and Emissions Report

Transaction Year: 2019 Transaction Month: April Account Item Code: REGISTRATION EMISSIONS FEE, SALES TAX FEE, SALES TAX EMISSIONS FEE, SALES TAX EMISSION FEE 1%, SALES TAX PENALTY FEE, TERP FEE, TEXAS MOBILITY FUND FEE, YOUNG FARMER PROGRAM

Office: 028 - CALDWELL

County: 028 - CALDWELL Total Item Price: \$18,860.00

Account Item Code Description: TEXAS MOBILITY FUND FEE Items sold: 943

Voided: 17

Table with 8 columns: Transaction ID, Amount, Transaction ID, Amount, Transaction ID, Amount, Transaction ID, Amount. Lists 943 items sold and 17 voided items.

Run Date: 05/06/2019 Run Time: 8:40:08 AM

Page 7 of 11

RTS Date: 05/03/2019



Texas Department of Motor Vehicles

Texas Department of Motor Vehicles

RTS.FIN.009

MONTHLY FUNDS REPORT

For: April 2019

Registration and Title System Report

Transaction Year: 2019 Transaction Month: April Account Item Code: REGISTRATION EMISSIONS FEE, SALES TAX FEE, SALES TAX EMISSIONS FEE, SALES TAX EMISSION FEE 1%, SALES TAX PENALTY FEE, TERP FEE, TEXAS MOBILITY FUND FEE, YOUNG FARMER PROGRAM

Office: 028 - CALDWELL

County: 028 - CALDWELL Total Item Price: \$18,860.00

Account Item Code Description: TEXAS MOBILITY FUND FEE

Items sold: 943

Voided: 17

Table with 8 columns: Item ID, Amount, Item ID, Amount, Item ID, Amount, Item ID, Amount. Lists 943 items sold and 17 voided items.

Run Date: 05/06/2019 Run Time: 8:40:08 AM

Page 8 of 11

RTS Date: 05/03/2019



Texas Department of Motor Vehicles

Texas Department of Motor Vehicles

RTS.FIN.009

MONTHLY FUNDS REPORT

For: April 2019

Registration and Title System Report

Transaction Year: 2019 Transaction Month: April Account Item Code: REGISTRATION EMISSIONS FEE, SALES TAX FEE, SALES TAX EMISSIONS FEE, SALES TAX EMISSION FEE 1%, SALES TAX PENALTY FEE, TERP FEE, TEXAS MOBILITY FUND FEE, YOUNG FARMER PROGRAM

Office: 028 - CALDWELL

County: 028 - CALDWELL Total Item Price: \$18,860.00

Account Item Code Description: TEXAS MOBILITY FUND FEE Items sold: 943

Voided: 17

Table with 8 columns: Item ID, Amount, Item ID, Amount, Item ID, Amount, Item ID, Amount. Lists 943 items sold and 17 voided items.

Run Date: 05/06/2019 Run Time: 8:40:08 AM

Page 9 of 11

RTS Date: 05/03/2019



MONTHLY FUNDS REPORT

For: April 2019

Registration and Title System Report

Transaction Year: 2019 Transaction Month: April Account Item Code: REGISTRATION EMISSIONS FEE, SALES TAX FEE, SALES TAX EMISSIONS FEE, SALES TAX EMISSION FEE 1%, SALES TAX PENALTY FEE, TERP FEE, TEXAS MOBILITY FUND FEE, YOUNG FARMER PROGRAM

Office: 028 - CALDWELL

County: 028 - CALDWELL Total Item Price: \$18,860.00

Account Item Code Description: TEXAS MOBILITY FUND FEE Items sold: 943 Voids: 17

Table with 8 columns: Item ID, Amount, Item ID, Amount, Item ID, Amount, Item ID, Amount. Lists 943 items sold and 17 voids for Texas Mobility Fund Fee.

G. \$253.75 (Texas Boat and Motor Sales); Backup: 3

Caldwell County Agenda Item Request Form

To: All Elected Officials and Department Heads – Hand deliver or scan & email to hoppy.haden@co.caldwell.tx.us and ezzy.chan@co.caldwell.tx.us . Deadline is 5:00 pm Tuesday before the Regular meetings, however, please submit this completed form ASAP. "Anything missing will cause the Agenda Item to be held over to the next Regular meeting," according to our Rules & Procedures.

AGENDA DATE: 5/13/2019

Type of Agenda Item

- Consent Discussion/Action Executive Session Workshop
 Public Hearing

What will be discussed? What is the proposed motion?

to accept payments to Comptroller, Texas Parks and Wildlife in the amount of \$253.75

1. Costs:

Actual Cost or Estimated Cost \$ 253.75

Is this cost included in the County Budget? yes

Is a Budget Amendment being proposed? no

2. Agenda Speakers:

Name	Representing	Title
------	--------------	-------

(1) _____

(2) _____

(3) _____

3. Backup Materials: None To Be Distributed 3 total # of backup pages
(including this page)

4.  _____
Signature of Court Member

Date 5/7/2019



Texas Boat and Boat Motor Sales and Use Tax Report

You have certain rights under Chapters 552 and 569, Government Code, to review, request and correct information we have on file about you. Contact us at the address or phone number listed on this form.

a. 57100

c. Taxpayer number
32049986444

d. Filing period
Month Ending 04/30/2019

e.

f. Due date
05/10/2019

g. Name and mailing address (Make any necessary name or address changes below.)

The Honorable Darla Law (Caldwell County TAC)
110 S Main St Room 101
Lockhart, Texas 78644

h. IMPORTANT

Blacken this box if your mailing address has changed. Show changes by the preprinted information.

i.

j.

1. Number of receipts issued (Including Voids)	1. 20
TAX COMPUTATION	
Report dollars and cents.	
2. Gross Boat & Boat Motor Sales and Use Tax collected	2. \$ 267.11
3. Tax Assessor-Collector/Department fee (5% of Item 2)	3. 13.36
4. Net taxes collected (Item 2 minus Item 3)	4. 253.75
5. Interest earned	5.
6. TOTAL AMOUNT DUE (Item 4 plus Item 5)	6. 253.75
Form 57-100 (Rev.12-18/8) *** DO NOT DETACH ***	
7. Total amount of prepayments	7.
8. TOTAL AMOUNT DUE AND PAYABLE (Item 6 minus Item 7)	8. \$ 253.75

Taxpayer name
The Honorable Darla Law (Caldwell County TAC)

T Code Taxpayer number Period

Make check payable to State Comptroller.
Mail to Comptroller of Public Accounts
P.O. Box 149360
Austin, TX 78714-9360

I declare that the information in this document and any attachments is true and correct to the best of my knowledge and belief.

Duly authorized agent
sign here *[Signature]*
Business phone 512-398-1830 Date 05/06/2019



Caldwell - Main

04/01/2019 - 04/30/2019

Order Id	Order Date	Asset	Total Transaction Amount Collected	Sales Tax Collected in Transaction	Less 5% Tax Retained by County	Total Donation Collected	Tax Amount Due Comptroller
12755046	04/01/2019	B3878EX	\$ 102.74	\$ 32.74	\$ 1.64	0.00	\$ 31.10
12760939	04/04/2019	B4600DU	\$ 53.00	\$.00	\$.00	0.00	\$.00
12761205	04/04/2019	B7897HM	\$ 53.00	\$.00	\$.00	0.00	\$.00
12847174	04/08/2019	B2434DP	\$ 116.25	\$ 46.25	\$ 2.31	0.00	\$ 43.94
12847174	04/08/2019	M3248FP	\$ 73.88	\$ 46.88	\$ 2.34	0.00	\$ 44.54
12855449	04/11/2019	B4518JF	\$ 53.00	\$.00	\$.00	0.00	\$.00
12858044	04/12/2019	B3536JR	\$ 126.25	\$ 35.25	\$ 1.76	0.00	\$ 33.49
12864315	04/16/2019	B7537ER	\$ 80.00	\$.00	\$.00	0.00	\$.00
12864315	04/16/2019	M9352DC	\$ 27.00	\$.00	\$.00	0.00	\$.00
12864427	04/16/2019	B7537ER	\$.00	\$.00	\$.00	0.00	\$.00
12864427	04/16/2019	M9352DC	\$.00	\$.00	\$.00	0.00	\$.00
12864843	04/16/2019	B8090JU	\$ 53.00	\$.00	\$.00	0.00	\$.00
12876932	04/23/2019	B4584AU	\$ 125.39	\$ 34.39	\$ 1.72	0.00	\$ 32.67
12876932	04/23/2019	M1724CW	\$ 27.00	\$.00	\$.00	0.00	\$.00
12877341	04/23/2019	B4584AU	\$.00	\$.00	\$.00	0.00	\$.00
12877341	04/23/2019	M1724CW	\$.00	\$.00	\$.00	0.00	\$.00
12881028	04/25/2019	B1762FV	\$ 111.60	\$ 41.60	\$ 2.08	0.00	\$ 39.52
12881028	04/25/2019	M5826DU	\$ 27.00	\$.00	\$.00	0.00	\$.00
12883997	04/26/2019	B1934ES	\$ 95.00	\$ 15.00	\$.75	0.00	\$ 14.25
12883997	04/26/2019	M2741FS	\$ 42.00	\$ 15.00	\$.75	0.00	\$ 14.25

Total Transaction Amount Collected: \$1,166.11

Total Sales Tax Collected: \$267.11

Total Retained by County: \$13.36

Total Donations: 0.00

Total Due Comptroller for this period: \$253.75

H. \$163,408.55 (Department of Motor Vehicles Fees - April 2019); Backup: 2

Caldwell County Agenda Item Request Form

To: All Elected Officials and Department Heads – Hand deliver or scan & email to hoppy.haden@co.caldwell.tx.us and ezzy.chan@co.caldwell.tx.us . Deadline is 5:00 pm Tuesday before the Regular meetings, however, please submit this completed form ASAP. "Anything missing will cause the Agenda Item to be held over to the next Regular meeting," according to our Rules & Procedures.

AGENDA DATE: 5/13/2019

Type of Agenda Item

- Consent Discussion/Action Executive Session Workshop
- Public Hearing

What will be discussed? What is the proposed motion?

to accept April 2019 payment for Texas Department of Motor Vehicles Fees in the amount of \$163,408.55

1. Costs:

Actual Cost or Estimated Cost \$ 163,408.55

Is this cost included in the County Budget? yes

Is a Budget Amendment being proposed? no

2. Agenda Speakers:

Name	Representing	Title
(1) _____	_____	_____
(2) _____	_____	_____
(3) _____	_____	_____

3. Backup Materials: None To Be Distributed 2 total # of backup pages (including this page)

4. 
Signature of Court Member

Date 5/7/2019



\$163,408.55

RTS: County Funds Remittance - Internet Explorer

https://rts1.bc... RTS: County Funds Remitt...



Texas Department of Motor Vehicles

REGISTRATION & TITLE SYSTEM

Customer Miscellaneous Reports Local Options Accounting Inventory Funds Exit Help

Funds Due Summary ACC017

Select a report using arrow keys and press enter

Due Date	Funds Report Date	Reporting Date	Total Amount Due	Remittance Amount
04/17/2019	04/15/2019	04/15/2019	658.00	0.00
04/18/2019	04/18/2019	04/18/2019	714.00	0.00
04/18/2019	04/17/2019	04/17/2019	401.00	0.00
04/22/2019	04/18/2019	04/18/2019	485.00	0.00
04/23/2019	04/20/2019	04/20/2019	37810.13	0.00
04/24/2019	04/22/2019	04/22/2019	1131.00	0.00
Totals:			163408.55	0.00

Enter Cancel

USER 026-DLAW, CALDWELL COUNTY, CALDWELL COUNTY MAN

POS Version 9.2.0 (12/11/2013)

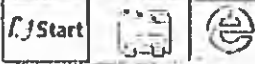

10:23 AM 5/6/2019

**I. \$29,447.68 (April 2019 Utilities);
Backup: 2**

Caldwell County Agenda Item Request Form

To: All Elected Officials and Department Heads – Hand deliver or scan & email to hoppy.haden@co.caldwell.tx.us and ezzy.chan@co.caldwell.tx.us . Deadline is 5:00 pm Tuesday before the Regular meetings, however, please submit this completed form ASAP. "Anything missing will cause the Agenda Item to be held over to the next Regular meeting," according to our Rules & Procedures.

AGENDA DATE: 5/13/19

Type of Agenda Item

- Consent Discussion/Action Executive Session Workshop
 Public Hearing

What will be discussed? What is the proposed motion?

to accept Utility payments totaling \$29,447.68

1. **Costs:**

Actual Cost or Estimated Cost \$ 29,447.68

Is this cost included in the County Budget? yes

Is a Budget Amendment being proposed? NO

2. **Agenda Speakers:**

Name	Representing	Title
------	--------------	-------

(1) _____

(2) _____

(3) _____

3. **Backup Materials:** None To Be Distributed 2 total # of backup pages
(including this page)

4.  _____
Signature of Court Member

Date 5/7/2019

Bill Name	Location	Apr-19
Maxwell Water Supply Corp.	Hwy 142/CCR 239 & FM 1966 JP 3	34.62
	MAXWELL WATER SUPPLY CORP. - TOTAL	34.62
Polonia Water Supply Corp.	Caldwell County Unit Rd	34.36
Polonia Water Supply Corp.	Caldwell Co. Prec. 4-49 Civic Dr., Dale, TX	26.99
	POLONIA WATER SUPPLY CORP. - TOTAL	61.35
Texas Gas Service	Caldwell County Jail #2, 1204 Reed Rd CCSO	1,103.42
	Caldwell County 405 E. Market, Lockhart	98.97
	County Bldg Luling, 510 E Pierce, Luling	119.71
	Caldwell County #2, 401 E. Market, Lockhart	83.40
	Caldwell Cty Juv Prob Dept	75.74
	Caldwell Co. New Building-1703 S. Colorado	184.72
	TEXAS GAS SERVICE - TOTAL	1,665.96
City of Lockhart - CALDCO 01	Caldwell Co. Annex, 405 E. Market	273.63
	Caldwell Co. Annex, 405 E. Market	89.13
	CITY OF LOCKHART - CALDCO 01 -TOTAL	362.76
City of Lockhart - CALDCO 02	Caldwell Co. Annex, 110 S. Main	1,722.23
	Bkroom, 312 E. San Antonio SERVER RM	351.97
	CC Juvenile Prob. Dept, 312 E. San Antonio	601.37
	CC Annex, CC Courthouse, 401 E. Market	391.09
	CC District Resource Cent, 401 E. Market - DRC	355.07
	Caldwell Co. Annex, 110 S. Main-Sprinkler	39.83
	CC Judicial Center, 1703 S. Colorado	5,462.48
	CC Judicial Center, 1703 S. Colorado	39.83
	Caldwell Co. Annex, 1196 Reed Dr.-Barn MAINT.	186.39
	Caldwell Co. Annex, Blackjack	1,457.91
	Caldwell Co. Annex, 1204 Reed Dr. CCSO	14,862.25
	Caldwell Co. Annex, 1403 Blackjack-LW School	387.74
	Caldwell Co. Annex, 1403 Blackjack-Maint Bldg	146.01
	CITY OF LOCKHART - CALDCO 02 - TOTAL	26,004.17
City of Luling - CALDWELL	Caldwell Co-JP/County Auditor, 508 N. Fannin St	240.14
Statement date usually end of the month.	Caldwell Co-Adult/Juv Serv, 512 E. Fannin St.	49.25
	Caldwell Co. Welfare Off, 505 E. Fannin St.	86.20
	Caldwell Co Prec. #2, 423 San Marcos Hwy.	51.56
	CITY OF LULING - CALDWELL - TOTAL	427.15
Bluebonnet Electric	Caldwell County Precint #3	182.81
	Caldwell County Prec 4	85.65
Bluebonnet Electric	Caldwell County URS	510.87
	Sanitation - meter no: 122860878/43673230	112.34
	BLUEBONNET ELECTRIC - TOTAL	891.67

Total Utilities Paid: 29,447.68

- 4. Accept January-March 2019 Reports from Caldwell County Extension Office:**
 - A. Julie Zimmerman; Backup: 3**
 - B. Wayne Morse (Jan – Apr); Backup: 8**
 - C. Elsie Lacy; Backup: 6**

Caldwell County Agenda Item Request Form

To: All Elected Officials and Department Heads – Hand deliver or scan & email to hoppy.haden@co.caldwell.tx.us and ezzy.chan@co.caldwell.tx.us . Deadline is 5:00 pm Tuesday before the Regular meetings, however, please submit this completed form ASAP. "Anything missing will cause the Agenda Item to be held over to the next Regular meeting," according to our Rules & Procedures.

AGENDA DATE: 5/13/2019

Type of Agenda Item

- Consent Discussion/Action Executive Session Workshop
 Public Hearing

What will be discussed? What is the proposed motion?

to accept January-March 2019 reports from Caldwell County Extension Office:

- Julie Zimmerman
- Wayne Morse
- Elsie Lacy

1. **Costs:**

Actual Cost or Estimated Cost \$ _____

Is this cost included in the County Budget? _____

Is a Budget Amendment being proposed? _____

2. **Agenda Speakers:**

Name	Representing	Title
------	--------------	-------

(1) _____

(2) _____

(3) _____

3. **Backup Materials:** None To Be Distributed 16 total # of backup pages
(including this page)

4.  _____
Signature of Court Member

Date 5/7/2019

Julie Zimmerman's 2019 commissioner's court reports

January 2019

- 2 – Office
- 3 – Master Gardener (MG) board meeting
- 4 – Off
- 7 – Office & MG meetings
- 8 – LFF planning day
- 9-11 – office and site visits
- 12 – Master Naturalist (MN) class – instruct
- 14 – Commissioner's court, office
- 15-16 – out
- 17 – office half day, increment report
- 18 – go to College Station – pick up broilers, increment report, Luling Livestock show
- 19 – Luling Livestock show
- 22 – office
- 23 – livestock coalition meeting
- 24-25 – office
- 28 – 4-H council
- 29 – half day office
- 30 – office, scholarship committee meeting
- 31 – Meeting with multi-county planning group, prep for LAB

Social media outreach

Instagram 12 posts, 566 followers
Facebook posts 13, 622 followers
4-H Blog & ag blog – 19 posts

Emails - 585

phone calls/texts - 309

2 articles in local newspapers with readership of 15,000

Julie Zimmerman's 2019 commissioner's court reports

February 2019

- 1 – Leadership advisory board meeting
- 2 – project show and rabbit validation
- 4 – office
- 5 – legal liabilities workshop, Master Gardener board meeting
- 6 – taught auxin course to row crop farmers
- 7 – meeting with Daphne Richards about horticulture programming
- 8 – Dairy Judging at San Antonio Livestock show
- 11 – commissioner's court, meeting with future 4-H parent
- 12 – plum creek watershed stewardship committee meeting, master gardener meeting
- 13 – office
- 14 – office
- 15 – Master gardener meeting, office
- 18 – off
- 19 – off
- 20 – taught Pesticide applicator course
- 21 – site visits
- 22 – scholarship interviews
- 24 – fishing class at Schmidt Ranch
- 25 – 4-H county council
- 26 – office and off part of day
- 27 – performance appraisal
- 28 - off

Social media outreach

Instagram 18 posts, 566 followers
Facebook posts 18, 679 followers
4-H Blog & ag blog – 18 posts

Emails - 2185

phone calls/texts - 916

1 article in local newspapers with readership of 15,000

March

- 1 - sick day
- 4 - in office
- 5 - office & MG board meeting
- 6 - office & MG class
- 7 - work on feral hog demonstration at LFF
- 8 - office and head to (Houston livestock show & rodeo) HLSR
- 9 - HLSR
- 11 - office
- 12 - office, site visit, MG general mtg.
- 13 - office, MG class
- 14, 15, 18 - out of office
- 19 - office, site visit
- 20 - office, MG class
- 21 - site visit, office
- 22 - office
- 23-30 - Rodeo Austin

1 article in 2 newspapers - readership 15,000

facebook- posts:16, followers: 642
Instagram- 15, followers: 431
Posts to external blog-10, followers: 1300
Phone, email, snail mail - 1544

Julie Zimmerman

MAJOR PLANS FOR NEXT MONTH:

DATE	PLANS
02/1/19	LAB Meeting
02/7/19- 02/22/19	San Antonio Stock Show and Rodeo
02/28/19	CCJLS

MILES	#480
SITE CONTACTS	#NA
PHONE	#85
BLOG	#
NEWS COLUMNS	#1
NEWS RELEASES	#
EMAIL	#250

I here certify this is a true and correct report of travel (mileage) and other expenses incurred by me in performance of my official duties for the month shown.

SIGNATURE 

Title CEA 4-H/ANR-

Date 2-4-19

Texas A&M AgriLife Extension*The Texas A&M University System*Dr. Douglas Steele, Director*College Station, TX

MAJOR PLANS FOR NEXT MONTH:

DATE	PLANS
03/1/19- 3/2/19	CCJLS
3/5/19- 3/7/19	Houston Livestock Show
3/12/19	County Roundup
3/18/19- 3/23/19	Austin Livestock Show
3/28/19- 3/30/19	Austin Livestock Show plus Austin Judging Contest

MILES	#1500
SITE CONTACTS	#5
PHONE	#115
BLOG	#2
NEWS COLUMNS	#1
NEWS RELEASES	#
EMAIL	#220

I here certify this is a true and correct report of travel (mileage) and other expenses incurred by me in performance of my official duties for the month shown.

SIGNATURE  _____

Title CEA 4-H/ANR-

Date 3/08/19

Texas A&M AgriLife Extension*The Texas A&M University System*Dr. Douglas Steele, Director*College Station, TX

MAJOR PLANS FOR NEXT MONTH:

DATE	PLANS
04/5/19	Beef Forage Field Day
4/10/19	Award interviews
4/10/19- 4/11/19	TCAA
4/17/19	LAB Meeting
4/25/19	Beef Program at the County Show Barn

MILES	#NA
SITE CONTACTS	#5
PHONE	#115
BLOG	#2
NEWS COLUMNS	#1
NEWS RELEASES	#
EMAIL	#220

I here certify this is a true and correct report of travel (mileage) and other expenses incurred by me in performance of my official duties for the month shown.

SIGNATURE 

Title CEA 4-H/ANR-

Date 4-1-19

Texas A&M AgriLife Extension*The Texas A&M University System*Dr. Douglas Steele, Director*College Station, TX

MAJOR PLANS FOR NEXT MONTH:

DATE	PLANS
5/2/19- 5/3/19	District 10 Roundup in Fredricksburg
5/10/19	Professional Development in Uvalde
5/15/19- 5/15/19	Professional Development in College Station
5/16/19	Luling Foundation Annual Field Day
5/20/19	Water Fair at Clearfork Elementary
5/21/19	Ag Literacy Day at Luling Foundation
5/23/19- 5/24/19	Spring Conference in Uvalde

MILES	#NA
SITE CONTACTS	#NA
PHONE	#103
BLOG	#2
NEWS COLUMNS	#1
NEWS RELEASES	#
EMAIL	#200

I here certify this is a true and correct report of travel (mileage) and other expenses incurred by me in performance of my official duties for the month shown.

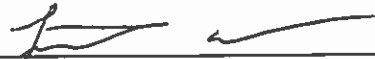
SIGNATURE 

Title CEA 4-H/ANR-

Date 5/1/19

TEXAS A&M AGRI LIFE EXTENSION

Texas A&M AgriLife Extension Service The Texas A&M University System

Name: Elsie Lacy Title: County Extension Agent-FCH
 County: Caldwell Month: January 2019

DATE	Monthly Activities/Travel	MILES	MEALS	LODGING
2-4	vacation	0		
8	Retired teachers educational program on health and downsizing- Senior Center- Lockhart (18 Adult F)	0		
8	Met with Adult Plum Creek Leader-Amanda Marlatt – Extension Office Lockhart	0		
9	Worked with Nicole Bittner, Emma Anton and Megan Rogers Scholarships- due to office.	0		
10	Multi-County Child-Care-Bastrop	59		
13	EEA Board Meeting	0		
13-16	Trip leaving and arriving Dallas Love Field for Chevy Chase Maryland for training on grant from Microsoft and National 4-H Foundation	462		
18	Travis County Junior Livestock show Food Judge-Austin	68		
18-19	Luling Junior Livestock Show- Luling	30		
22	Scholarship Committee Meeting-Scott Annex Lockhart	0		
25	Worked with Megan Rogers and Emma Anton on scholarship submissions for 4-H-Lockhart	0		
28	4-H Council Meeting- Scott Annex Lockhart	0		
29	Learn Grow Eat Go Meeting with Science Teacher-Prairie Lea	28		
30	Scholarships approved on county level pending at District.	0		
GRAND TOTAL OF MILEAGE, MEALS & LODGING		647		

CURRENT MONTHS CONTACTS							
Extension Office Visits by Clientele	Site Visits Farm, Home, Project Ranch, Business, Etc	Telephone	Mail	Total Individual Contacts	Total Contact Hours in Group Methods	Media News Articles, TV/Radio, Etc	Newsletters Written
25	2	22	142	59	29	1	1

MAJOR PLANS FOR NEXT MONTH	
DATE	ACTIVITY
1	Leadership Advisory Board-TCFF planning
5	LGEG Presentation to Master Gardeners
6	Lockhart EEA Monthly Meeting
7	Luling EEA Monthly Meeting
7	San Antonio Stock Show and Rodeo Food Challenge Judge
11	TEEA District Scholarship due to office
12	LGEG Meeting with Prairie Lea teacher
13	Multi-County Child-Care Planning Meeting Conference Call
14-15	Vacation
19	LGEG Prairie Lea
19	EEA Council Board Meeting
19	District 10 TEA-FCS - San Antonio
21	Chamber of Commerce Banquet- Lockhart
22	Caldwell County Scholarship Interviews
23	William Taylor Health Fair
23	CCJLS Barn Clean up
25	Commissioners Court to discuss 4-H meeting room
26	LGEG Prairie Lea
27	Performance Appraisal

PAGE 2 of 2

I hereby certify this is a true and correct report of activities, travel, and other expenses incurred by me in performance of official duties for the month shown.

Date: February 2019 _____

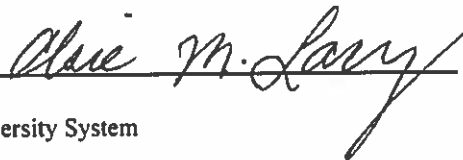
Signed: 

Texas A&M AgriLife Extension Service * The Texas A&M University System
College Station, Texas



Texas A&M AgriLife Extension Service
The Texas A&M University System

Name: Elsie Lacy Title: County Extension Agent-FCH
 County: Caldwell Month: February 2019

DATE	Monthly Activities/Travel	MILES	MEALS	LODGING
1	Leadership Advisory Board-TCFF planning-Lockhart meeting room	0		
2	Sign up for Project Fair-Lockhart Ag Barn (Weekend Event)	0		
5	LGEG Presentation to Master Gardeners-Lockhart	0		
6	Lockhart EEA Monthly Meeting-Lockhart	0		
7	Luling EEA Monthly Meeting-Luling	28		
7	San Antonio Stock Show and Rodeo Food Challenge Judge-San Antonio	127		
11	TEEA District Scholarship due to office	0		
12	LGEG Meeting with Prairie Lea teacher-Prairie Lea	28		
13	Multi-County Child-Care Planning Meeting Conference Call	0		
14-15	Vacation	0		
19	LGEG- Prairie Lea	28		
19	EEA Council Board Meeting-Lockhart	0		
21	Chamber of Commerce Banquet- Lockhart	0		
22	Bought LGEG materials with Master Gardener Tommie Clayton-San Marcos Transportation provided by Master Gardeners	0		
22	Caldwell County Scholarship Interviews (Evening Event)	0		
23	William Taylor Health Fair-Luling (Weekend Event)	28		
23	CCJLS Barn Clean up-Lockhart (Weekend Event)	0		
25	Commissioners Court Meeting to discuss meeting room use-Lockhart	0		
26	LGEG- Prairie Lea	28		
27	Performance Appraisal-Lockhart	0		
28	LGEG- Prairie Lea	28		
28	Caldwell County Junior Livestock Show-check in and Project Fair set up- Lockhart (Evening Event)	0		
GRAND TOTAL OF MILEAGE, MEALS & LODGING		295		

CURRENT MONTHS CONTACTS							
Extension Office Visits by Clientele	Site Visits Farm, Home, Project Ranch, Business, Etc	Telephone	Mail	Total Individual Contacts	Total Contact Hours in Group Methods	Media News Articles, TV/Radio, Etc	Newsletters Written
10	4	71	287	687	58	7	

MAJOR PLANS FOR NEXT MONTH	
DATE	ACTIVITY
1-2	Caldwell County Junior Livestock Show and Project Fair
6	Meeting with FCH agents from Bastrop and Hayes with Bertha Martinez at Dr. Eugene Clark Library
6	Conference Call for Multi-county Child Care Conference
7	Learn Grow Eat Go-Prairie Lea
11	County EEA Scholarship Application due
12	Learn Grow Eat Go-Prairie Lea
12	County Roundup
14-16	Microsoft and National 4-H Digital Ambassador Training-Chicago, IL
19	EEA Council Meeting
20	Meet with Callahan's and Sonia Coyle FCH agent to plan Food Preservation
21	County Duds to Dazzle Contest
25	Commissioners Court for Digital Ambassadors Presentation
25	4-H Council Meeting
26	Learn Grow Eat Go-Prairie Lea
26	Record book Training
28	Fashion Storyboard Training

PAGE 2 of 2

I hereby certify this is a true and correct report of activities, travel, and other expenses incurred by me in performance of official duties for the month shown.

Date: March 2019

Signed: *Christie M. Lopez*

Texas A&M AgriLife Extension Service * The Texas A&M University System, College Station, Texas

TEXAS A&M
AGRI LIFE
EXTENSION

Texas A&M AgriLife Extension Service
The Texas A&M University System

Name: Elsie Lacy Title: County Extension Agent-FCH

County: Caldwell Month: March 2019

DATE	Monthly Activities/Travel	MILES	MEALS	LODGING
1-2	Caldwell County Junior Livestock Show and Project Fair (Weekend and Evening Event)	0		
5	Learn Grow Eat Go-Prairie Lea	28		
6	Meeting with FCH agents from Bastrop and Hayes with Bertha Martinez at Dr. Eugene Clark Library	0		
6	Conference Call for Multi-county Child Care Conference	0		
6	Purchased equipment and materials for 4-H "Duds to Dazzle" Competition-Kyle (78640)	44		
11	County EEA Scholarship Application due	0		
12	Learn Grow Eat Go-Prairie Lea	28		
14-16	Microsoft and National 4-H Digital Ambassador Training-Chicago, IL (60666) (Weekend and Evening Event)(Transportation and lodging paid for by grant)	0		
19	EEA Council Meeting with judging of scholarships afterwards	0		
20	Meet with Callahan's and Sonia Coyle FCH agent to plan Food Preservation (78741)	57		
21	County Duds to Dazzle Contest Training (Evening Event)	0		
25	Commissioners Court for Digital Ambassadors Presentation	0		
25	4-H Council Meeting (Evening Event)	0		
26	Learn Grow Eat Go-Prairie Lea	28		
26	Record book Training (Evening Event)	0		
27	Purchased equipment and materials for 4-H "Fashion Storyboard" Competition and Child Care Training-San Marcos (78666)(Evening Event)	29		
28	Fashion Storyboard Training (Evening Event)	0		
GRAND TOTAL OF MILEAGE, MEALS & LODGING		214		

CURRENT MONTHS CONTACTS							
Extension Office Visits by Clientele	Site Visits Farm, Home, Project Ranch, Business, Etc.	Telephone	Mail	Total Individual Contacts	Total Contact Hours in Group Methods	Media News Articles, TV/Radio, Etc	Newsletters Written
18	4	57	241	471	150	8	1

MAJOR PLANS FOR NEXT MONTH

DATE	ACTIVITY
1	Hosted District TEEA 10 Cultural Arts Spring meeting
2	Learn Grow Eat Go-Prairie Lea
3	EEA Lockhart Meeting
4	EEA Luling Meeting
5	Met with Bastrop agent to set up for Child Care Traing
6	Child Care Training
8	Lockhart SHAC Meeting
9	Learn Grow Eat Go-Prairie Lea
10	Food Handlers- Master Gardeners
12	Married and Loving It
15	Judging Luling Foundation Scholarship
15	4-H Council Meeting
16	EEA Council Meeting
16	Learn Grow Eat Go-Prairie Lea
16	Go Texan Interviews 4-H Council Meeting
20	County Duds to Dazzle Training
22	Meeting with Bob Bullock museum coordinator
23	LAB meeting
23	Texas Communities Forum
24	Fashion Show Committee Uvalde
25	Share the Fun Committee Uvalde
26	Food Handlers
27	Health Fair Luling
29	Share the Fun Committee New Braunsfels
30	FCS Committee meeting
30	4-H Managers Training

PAGE 2 of 2

I hereby certify this is a true and correct report of activities, travel, and other expenses incurred by me in performance of official duties for the month shown.

Date: April 2019

Signed:

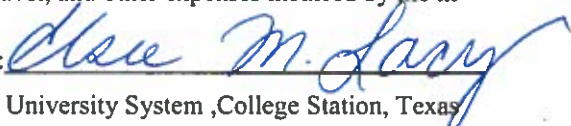

Texas A&M AgriLife Extension Service * The Texas A&M University System ,College Station, Texas

5. To accept February-March 2019 report from Constable, Precinct 2; Backup: 2

Caldwell County Agenda Item Request Form

To: All Elected Officials and Department Heads – Hand deliver or scan & email to hoppy.haden@co.caldwell.tx.us and ezzy.chan@co.caldwell.tx.us . Deadline is 5:00 pm Tuesday before the Regular meetings, however, please submit this completed form ASAP. "Anything missing will cause the Agenda Item to be held over to the next Regular meeting," according to our Rules & Procedures.

AGENDA DATE: 5/13/2019

Type of Agenda Item

- Consent Discussion/Action Executive Session Workshop
- Public Hearing

What will be discussed? What is the proposed motion?

to accept February and March 2019 report from Constable, Precinct 2

1. Costs:

Actual Cost or Estimated Cost \$ _____

Is this cost included in the County Budget? _____

Is a Budget Amendment being proposed? _____

2. Agenda Speakers:

Name	Representing	Title
(1) _____	_____	_____
(2) _____	_____	_____
(3) _____	_____	_____

3. Backup Materials: None To Be Distributed 2 total # of backup pages (including this page)

4.  _____
Signature of Court Member

_____ 5/7/2019 _____
Date

**CONSTABLE TOM WILL
CALDWELL COUNTY PRCT.2**

DAILY STATS 2019

	<u>JANUARY</u>	<u>FEBRUARY</u>	<u>MARCH</u>	<u>APRIL</u>	<u>MAY</u>	<u>JUNE</u>
TRAFFIC_CONTACTS	-	126	67	-	-	-
TRAFFIC_CITATIONS	-	78	26	-	-	-
TRAFFIC_WARNINGS	-	58	41	-	-	-
TRAFFIC_VIOLATIONS	-	62	29	-	-	-
WARRANTS_SERVED	-	-	-	-	-	-
WARRANTS_ATTEMPTS	-	-	-	-	-	-
WARRANTS_ARREST	-	-	-	-	-	-
EVICITION_ATTEMPTS	-	2	1	-	-	-
EVICITION_SERV_RETURNED	-	-	1	-	-	-
EVICITION_WORKING	-	2	-	-	-	-
CIVIL_CITATION_ATTEMPTS	-	6	8	-	-	-
CIVIL_CITATION_SERV_RETURNED	-	3	1	-	-	-
CIVIL_CITATION_WORKING	-	2	1	-	-	-
CIVIL_WARNING_ATTEMPTS	-	-	1	-	-	-
CIVIL_WARNING_SERV_RETURNED	-	-	1	-	-	-
CIVIL_WARNING_WORKING	-	-	-	-	-	-
CIVIL_WRIT_ATTEMPTS	-	1	3	-	-	-
CIVIL_WRIT_SERV_RETURNED	-	-	1	-	-	-
CIVIL_WRIT_WORKING	-	-	-	-	-	-
WARRANTS_SERVED	-	-	-	-	-	-
WARRANTS_ATTEMPTS	-	-	-	-	-	-
WARRANTS_ARREST	-	1	1	-	-	-
INVESTIGATIONS	-	15	4	-	-	-
COURT_HOURS	-	11	2	-	-	-
SPECIAL_EVENTS	-	3	3	-	-	-
ASSIST_OTHER_AGENCY	-	5	6	-	-	-
ASSIST_PUBLIC	-	11	12	-	-	-
ACCIDENTS	-	-	-	-	-	-
LIVE_STOCK	-	3	3	-	-	-
PROP_CHK	-	32	29	-	-	-
ALARMS	-	-	-	-	-	-
SELF_INT_CALLS	-	-	14	-	-	-
DISPATCHED	-	-	3	-	-	-

6. Accept the April 2019 Environmental Investigator report from Mike Bittner; Backup: 3

Caldwell County Agenda Item Request Form

To: **All Elected Officials and Department Heads** – Hand deliver or scan & email to hoppy.haden@co.caldwell.tx.us and ezzy.chan@co.caldwell.tx.us . Deadline is 5:00 pm Tuesday before the Regular meetings, however, please submit this completed form ASAP. “Anything missing will cause the Agenda Item to be held over to the next Regular meeting,” according to our Rules & Procedures.

AGENDA DATE: 5/13/2019

Type of Agenda Item

- Consent Discussion/Action Executive Session Workshop
 Public Hearing

What will be discussed? What is the proposed motion?

to accept the April 2019 Environmental Investigator report from Mike Bittner

1. Costs:

Actual Cost or Estimated Cost \$ None

Is this cost included in the County Budget? _____

Is a Budget Amendment being proposed? _____

2. Agenda Speakers:

	Name	Representing	Title
--	------	--------------	-------

(1) _____

(2) _____

(3) _____

3. Backup Materials: None To Be Distributed 3 total # of backup pages
(including this page)

4. 
Signature of Court Member

Date 5/7/2019



ENVIRONMENTAL CODE INVESTIGATOR REPORT

April 2019

Texas Health and Safety Codes: 343,341,365

Active Cases- THSC 343 -----	28
Cases- Citations issued for THSC 343 ----- (9) multiple charges	
Cases for THSC 343 that gained compliance -----	18
Cases for THSC 343 unfounded -----	5
Illegal Dumping cases that was reported -----	12
Cases for Illegal Dumping citation(s) -----	(0)
Cases for Flood Plain Violation(s) –Citation(s) issued -----	(0)
Cases for Flood Plain Active -----	1
Illegal Dump sites found while on patrol-----	12

Cases that are pending in the District Attorney's Office

----- 5

Cases pending that are filed in the JP Courts

----- (15)

Caldwell County Development ordinance and County Septic ordinance:

Active Construction permits Cases -----	3
Active Driveway permits Cases -----	1
Permit Cases reported that did not require a permit-----	4
Commercial Construction permits case -----	0
Construction Permit case CL/UN -----	4
Septic Cases Compliance met -----	1
Septic Cases Active -----	13
Septic Cases unfounded-----	1
Cases – Citation issued for Septic violations ----- (6) multiple charges	

Cases- Citation issued for attempted violation of the Development Ordinance – (0)

Permit Cases that gain compliance:

Construction Permits ----- 3
Driveway Permits ----- 2
Commercial Permit ----- 0

Follow up on issued permits for Driveways

Driveway permits in compliance ----- 16
Driveway permits that are not in compliance pipe violation--- 1

Refuse removed from County owned land

Tires, Garbage, Mattresses, Construction Refuse, Landscape Refuse and Household Rubbish. Total est. weight removed 2,300 lbs.

Other duties performed, investigated all called in complaints, case preparation, reports, citations, myself and Unit Road cleaned up dumpsites reported and found. Worked with Law Enforcement and State Agencies on cases to gain compliance.

If any member of the Court has any issues or question concerning violations in the County please contact me. I will do my best to get the issue resolved and compliance gained.



**C.C.E.I.
Mike Bittner**

7. Accept the Caldwell County Appraisal District's April 2019 Tax Collection Report. Backup: 4

Caldwell County Agenda Item Request Form

To: All Elected Officials and Department Heads – Hand deliver or scan & email to hopyy.haden@co.caldwell.tx.us and ezzy.chan@co.caldwell.tx.us . Deadline is 5:00 pm Tuesday before the Regular meetings, however, please submit this completed form ASAP. "Anything missing will cause the Agenda Item to be held over to the next Regular meeting," according to our Rules & Procedures.

AGENDA DATE: 5/13/2019

Type of Agenda Item

- Consent Discussion/Action Executive Session Workshop
 Public Hearing

What will be discussed? What is the proposed motion?

to accept the Caldwell County Appraisal District's April 2019 Tax Collection Report.

1. **Costs:**

Actual Cost or Estimated Cost \$ none

Is this cost included in the County Budget? _____

Is a Budget Amendment being proposed? _____

2. **Agenda Speakers:**

	Name	Representing	Title
--	------	--------------	-------

(1) _____

(2) _____

(3) _____

3. **Backup Materials:** None To Be Distributed 4 total # of backup pages
(including this page)

4.  _____
Signature of Court Member

Date 5/7/2019

CALDWELL COUNTY COMMISSIONERS

Tax Collection Report

APRIL 2019

	April	Prior Months	YTD TOTAL	PRIOR YEAR
2018 Tax Collection	\$123,308.47	\$16,379,629.73	\$16,502,938.20	\$15,203,688.99
2017 & Prior Collection	\$65,076.60	\$423,366.99	\$488,443.59	\$504,436.08
Total Tax Collection =	\$188,385.07	\$16,802,996.72	\$16,991,381.79	\$15,708,125.07

note: Above figures include penalties and interest collected

2018 Original Levy \$17,582,042.79

April 30, 2019 Percent of 2018 Tax Collected 93.55%

April 30, 2018 Percent of 2017 Tax Collected 93.51%

April 30, 2017 Percent of 2016 Tax Collected 93.39%

April 30, 2019 - Balance of Delinquent Tax \$1,441,675.38

April 30, 2018 - Balance of Delinquent Tax \$1,361,573.49

April 30, 2017 - Balance of Delinquent Tax \$1,303,692.16

Corrections made to Current Tax Roll (\$1,046.07)

Corrections made to Delinquent Tax Roll (\$775.79)

NOTE:

Caldwell County Appraisal District has collected and disbursed Attorney Fees in the amount of \$10,613.01

Submitted by:

Shanna Ramzinski

Shanna Ramzinski
Chief Appraiser
Caldwell County Appraisal District

CALDWELL COUNTY

Balance Sheet

APRIL 2019

DEPOSITS

Date	Amount		CHECK #
	M & O	I & S	
(1) 10-Apr-19	\$53,431.12	\$5,263.48	EFT
(2) 17-Apr-19	\$24,685.35	\$2,301.14	EFT
(3) 24-Apr-19	\$28,236.45	\$2,638.05	EFT
(4) 2-May-19	\$65,537.60	\$6,291.88	EFT
(5)	\$0.00	\$0.00	
(6)	\$0.00	\$0.00	
(7)	\$0.00	\$0.00	
(8)	\$0.00	\$0.00	
(9)	\$0.00	\$0.00	
(10)	\$0.00	\$0.00	
(11)	\$0.00	\$0.00	
(12)	\$0.00	\$0.00	
(13)	\$0.00	\$0.00	
(14)	\$0.00	\$0.00	
(15)	\$0.00	\$0.00	
(16)	\$0.00	\$0.00	
(17)	\$0.00	\$0.00	
(18)	\$0.00	\$0.00	
(19)	\$0.00	\$0.00	
(20)	\$0.00	\$0.00	
(21)	\$0.00	\$0.00	
(22)	\$0.00	\$0.00	
(23)	\$0.00	\$0.00	
(24)	\$0.00	\$0.00	
(25)	\$0.00	\$0.00	
Subtotals	<u>\$171,890.52</u>	<u>\$16,494.55</u>	
TOTAL ALL DEPOSITS	<u>\$188,385.07</u>		

CALDWELL COUNTY

Balance Sheet

APRIL 2019

Collections

	FARM TO MARKET M & O	GENERAL FUND	
		M & O	I & S
Current Tax	\$14.62	\$102,513.64	\$9,380.22
Current P & I	\$0.86	\$10,443.67	\$955.46
Delinquent Tax	\$8.84	\$39,166.04	\$3,991.67
Delinquent P & I	\$8.38	\$19,734.47	\$2,167.20
		Subtotals	
		\$171,857.82	\$16,494.55
TOTAL FTM	\$32.70	TOTAL GCA	\$188,352.37
	ROAD & BRIDGE M & O	STATE TAX M & O	
Current Tax	n/a	n/a	
Current P & I	n/a	n/a	
Delinquent Tax	\$0.00	\$0.00	
Delinquent P & I	\$0.00	\$0.00	
TOTAL RAB	\$0.00	TOTAL STX	\$0.00
		TOTAL COUNTY COLLECTIONS	
		\$188,385.07	

NOTE:

Caldwell County Appraisal District has collected and disbursed Attorney Fees in the amount of \$10,613.01

Attorney Fees Detail

FTM		\$2.24
GCA		\$10,610.77
RAB		\$0.00
STX		\$0.00

8. To accept a donation of a Risepro Sound Level Meter to Constable Precinct 2; Backup 3

Caldwell County Agenda Item Request Form

To: All Elected Officials and Department Heads – Hand deliver or scan & email to hoppy.haden@co.caldwell.tx.us and ezzy.chan@co.caldwell.tx.us . Deadline is 5:00 pm Tuesday before the Regular meetings, however, please submit this completed form ASAP. "Anything missing will cause the Agenda Item to be held over to the next Regular meeting," according to our Rules & Procedures.

AGENDA DATE: May 13, 2019

Type of Agenda Item

- Consent Discussion/Action Executive Session Workshop
 Public Hearing

What will be discussed? What is the proposed motion?

The donation of a Risepro Sound Level Meter to Precinct #2 Constable's Office.

1. **Costs:**

Actual Cost or Estimated Cost \$ 30.00

Is this cost included in the County Budget? No

Is a Budget Amendment being proposed? No

2. **Agenda Speakers:**

Name	Representing	Title
------	--------------	-------

(1) _____

(2) _____

(3) _____

3. **Backup Materials:**

None To Be Distributed 13 total # of backup pages (including this page)

4. Barbara Shelton
Signature of Court Member

5/6/2019
Date

**Commissioners Court-Monday May 13, 2019
County Purchasing Department
Anonymous Donation to PCT 2 Constable**

Discussion Items:

The County Purchasing Department is requesting the Commissioner's Court to accept the generous anonymous donation of a Risepro Sound Level Meter (SN: 201902038081) to be donated to Constable Precinct Two (2) Department. This donation has an estimated value of \$30.00. Once the Commissioner's Court accepts the donation, my department will put under county inventory to identify ownership.

Notable Budget Items: None at this time

Recommendation to Commissioner's Court:

County Purchasing Department respectfully recommends the following:

Acceptance of anonymous donation of a Risepro Sound Level Meter to Caldwell County Constable Precinct Two (2) Department.

Department Head Signature:

Danish Blah 5-7-19

Danielle Blake

From: Barbara Shelton <barbara.shelton@co.caldwell.tx.us>
Sent: Monday, May 06, 2019 5:20 PM
To: 'Danielle Blake'
Subject: Sound Level Meter
Attachments: Rise pro meter donation.pdf

Dani,
Risepro is the manufacturer for the Sound Level Meter (s/n 201902038081) that is being donated by an anonymous donor. Included is: the sound level meter, case and instructions as well as a 9 volt battery. This is being donated to the Precinct 2 Constable Department for them to use during noise complaints to measure the decibel level of the complaint. The value of the meter is \$30.
I have filled out the consent form and attached it for your review and if it isn't correct in wording, just let me know or you can do a new one and put at the bottom of the page phone approval of Barbara Shelton. Just let me know. Thank you for your assistance on this matter.

Barbara Shelton

Caldwell County

Commissioner Precinct 2

Cell: (512) 227-2555 Office: (512) 398-1808

Fax: (512) 398-1828

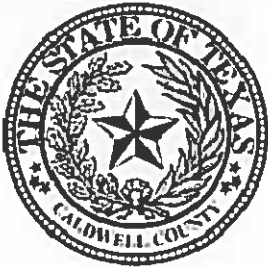

SPECIAL PRESENTATION

Mr. Nirav Ved, Special Assistant to the CAMPO Executive Director will provide a brief overview of the Luling Transportation Study; Backup: 39



Date: May 13, 2019
Continued From: N/A
Action Requested: Information

To: Caldwell County Commissioners Court
From: Mr. Nirav Ved, Special Assistant to the Executive Director
Subject: Presentation of Luling Transportation Study -

RECOMMENDATION

None. This item is for information purposes only.

PURPOSE AND EXECUTIVE SUMMARY

This item provides a presentation to the Caldwell County Commissioners Court on the Luling Transportation Study. Created to address increased traffic congestion in the downtown area, the study addresses current and future transportation needs within Luling, including the potential viability of a relief route.

The study recommends near term improvements mainly focused on intersection improvements and increased pedestrian connectivity. Proposed longer term improvements include the development of a new connector which includes a rail overpass and creates more efficient travel movements through, instead of around, Luling.

FINANCIAL IMPACT

Not applicable.

BACKGROUND AND DISCUSSION

Downtown Luling resides at the intersection of three major roadways, US 183, SH 80 and US 90 and serves as a crossroads for access to and from Austin, San Marcos, San Antonio and Houston. As activity in the Eagle Ford Shale has expanded, so has the presence of heavy trucks that must navigate tight turns and a Union Pacific rail line that bisects Luling. When a train is passing through during peak travel times, the resulting backup of heavy trucks and passenger vehicles can extend several miles in all directions.

The goals of the study were to identify needed safety improvements, enhance mobility in downtown for local and through traffic, evaluate the feasibility of a relief route, and promote the unique character of downtown.

SUPPORTING DOCUMENTS

Attachment A – *Results Summary*

Attachment B – *Survey Summary*

LULING

TRANSPORTATION STUDY

Results Summary Document – April 2019



Study Goals and Objectives

The purpose of the Luling Transportation Study is to evaluate conditions and transportation needs in Luling, to identify needed improvements, and to set an implementation plan for those improvements. Four project goals and associated objectives were established through coordination with the project steering committee.

Goal 1: Identify needed safety improvements

Objectives: Evaluate and consider

- Crash traffic data
- Bicycle and pedestrian travel
- Union Pacific Railroad and crossings
- Local EMS travel and evacuation routes

Goal 2: Enhance mobility in downtown for local and through traffic

Objectives: Evaluate and consider

- Local travel, freight travel, and recreational through travel
- Near, mid, and long-term improvements
- Ease of travelling public and emergency response to cross railroad tracks

Goal 3: Evaluate feasibility of an alternate route for through traffic (relief route/bypass)

Objectives: Evaluate and consider

- Future impacts with and without an alternate route
- Various future growth scenarios for Luling

Goal 4: Identify and incorporate tools to promote the unique character of downtown and economic development opportunities

Objectives: Evaluate and consider

- Effects on businesses
- Types and ranges of visitors to downtown Luling



Transportation Issues/Needs

Several issues were identified through site observations and conversation with the steering committee, local business owners, emergency responders, and members of the general public, as shown in **Table 1**.

Table 1 - Transportation Issues

#	Issue	Analysis	Needs and Potential Solutions
1	Queuing at southbound and westbound approaches to US 183 / US 90 / SH 80 intersection during peak periods.	<ul style="list-style-type: none"> Insufficient capacity of two-lane approaches compared to traffic volume. Signal timing scheme provides equal green time to through, right, and left turn movements though peak demand is from southbound left and westbound right movements. 	<ul style="list-style-type: none"> Add capacity at US 183 / US 90 / SH 80 intersection. Improve signal timing and lane utilization scheme. Provide relief route around northeast quadrant.
2	Diversion of traffic onto local streets during periods of peak congestion. Some local streets were not built to accommodate high volumes or heavy vehicles.	<ul style="list-style-type: none"> Eastbound traffic on SH 80 diverts to parallel streets ahead of US 183 intersection if increased queuing is perceived. Westbound traffic on US 183 / US 90 diverts to parallel streets (Cedar Avenue, Oak Avenue) ahead of US 183 / US 90 / SH 80 intersection if increased queuing is perceived. Degradation of pavement quality due to unanticipated heavy vehicle use. 	<ul style="list-style-type: none"> Add capacity at US 183 / SH 80 / E Austin Street and US 183 / US 90 / SH 80 intersections. Traffic calming countermeasures on local streets. Improve wayfinding and route signage. Provide relief route around northwest and northeast quadrants. Improve Hackberry Avenue so that some heavy truck and vehicle traffic reroutes from US 183 between US 90 and SH 80 Provide direct grade-separated connection between SH 80 and US 90 (west of Hackberry Avenue)



#	Issue	Analysis	Needs and Potential Solutions
3	Trains crossings delay traffic approaching and departing north leg of 183 / US 90 / SH 80 intersection by several minutes	<ul style="list-style-type: none"> Several closures of at-grade crossing near 183 / US 90 / SH 80 intersection each hour and upwards of 50 closures every day, lasting around two to three minutes each. 	<ul style="list-style-type: none"> Grade separation of alternate route. Provide relief route around northwest and northeast quadrants; provide dynamic display signs to influence route choice for drivers.
4	Occasionally, trains stall within downtown, blocking multiple crossing locations and limiting vehicle and emergency service	<ul style="list-style-type: none"> Feedback from Steering Committee and stakeholder outreach During these events, options for crossing the railroad are often limited to the Davis Street crossing (west) and Elm Avenue (east) 	<ul style="list-style-type: none"> Grade separation of existing or alternate route. New at-grade crossing and auxiliary route outside of downtown; UPRR typically request closures of at least two at-grade crossing to approve a new at-grade crossing.
5	Unsafe conditions for pedestrians on US 183 between US 90 and SH 80. Frequent vehicle collisions on this stretch of road can exacerbate traffic congestion.	<ul style="list-style-type: none"> Feedback from Steering Committee and stakeholder outreach No marked crosswalk currently exists at Davis Street / US 183 and no continuous sidewalks link to the nearest protected crossings Crash data from 2012 – 2017 shows high concentration of rear-end, left-turn, and right-angle crashes. Two crashes involving a pedestrian at US 183 / Davis occurred during this time span 	<ul style="list-style-type: none"> Improve Hackberry Avenue so that some heavy truck and vehicle traffic reroutes from US 183 between US 90 and SH 80 Provide relief route around northwest and/or northeast quadrants. Provide direct grade-separated connection between SH 80 and US 90 (west of Hackberry Avenue) Pedestrian crossing treatment at US 183 / Davis Street. Extend sidewalks along US 183.
6	Heavy freight traffic headed east-west via SH 80 and US 183, encounters bottleneck at US 183 / SH 80 / Austin Street and US 183 / US 90 / SH 80 intersections	<ul style="list-style-type: none"> StreetLight data indicates that this is movement with the heaviest daily and peak hour freight demand 	<ul style="list-style-type: none"> Improve Hackberry Avenue so that some heavy truck and vehicle traffic reroutes from US 183 between US 90 and SH 80 Provide direct grade-separated connection between SH 80 and US 90 (west of Hackberry Avenue) Reconfigure lane assignment and signal timing at US 183 / US 90 / SH 80 intersection



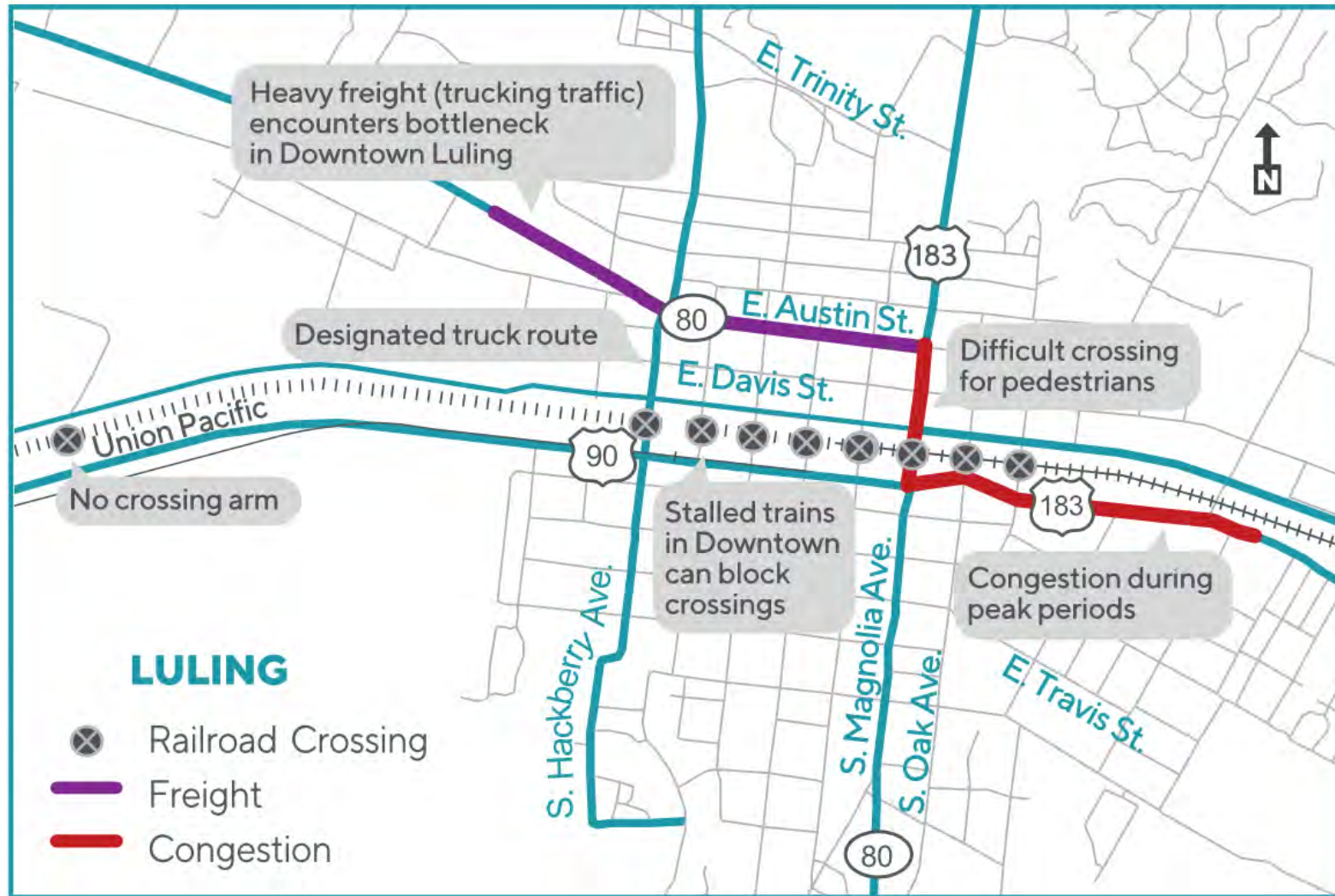

Figure 1 – Luling Issues Map



Traffic Data and Analysis

The following tables and figures display traffic counts and travel pattern information from several data sources. These counts were collected for the Luling study area to better understand traffic volume levels, truck activity, peaking characteristics, and directional distribution. Average annual daily traffic (AADT) counts from the TxDOT Traffic County Database System (TCDS) were compiled and summarized for approaching/departing study area roadways. Peak Period turning movement counts (TMCs) were collected for the five study area intersections in September 2018. Additionally, aggregated cell phone and GPS travel pattern data from StreetLight was extracted and analyzed to better understand peak Friday travel conditions and the most common routes of travel through the City.

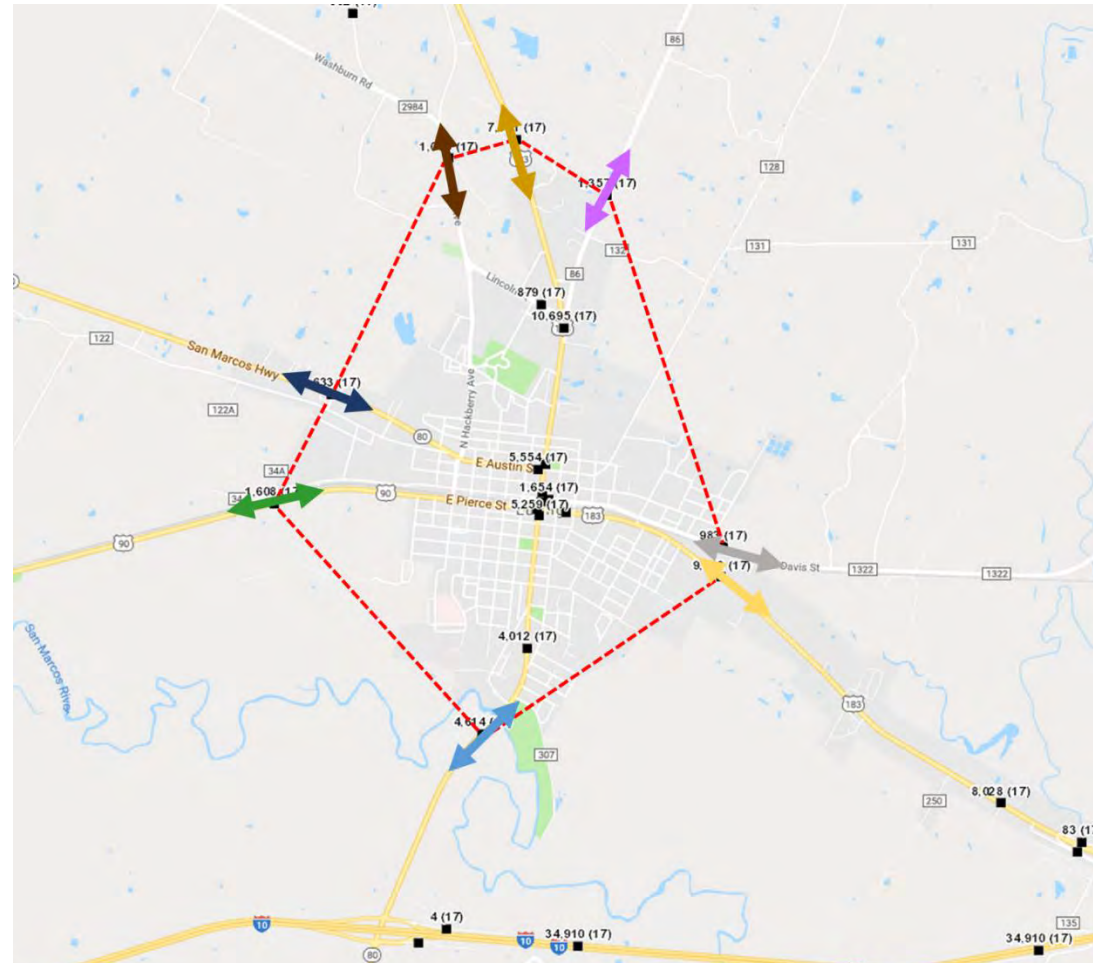

Figure 2 - 2017 Luling Study Area AADT (use with Figure 3)



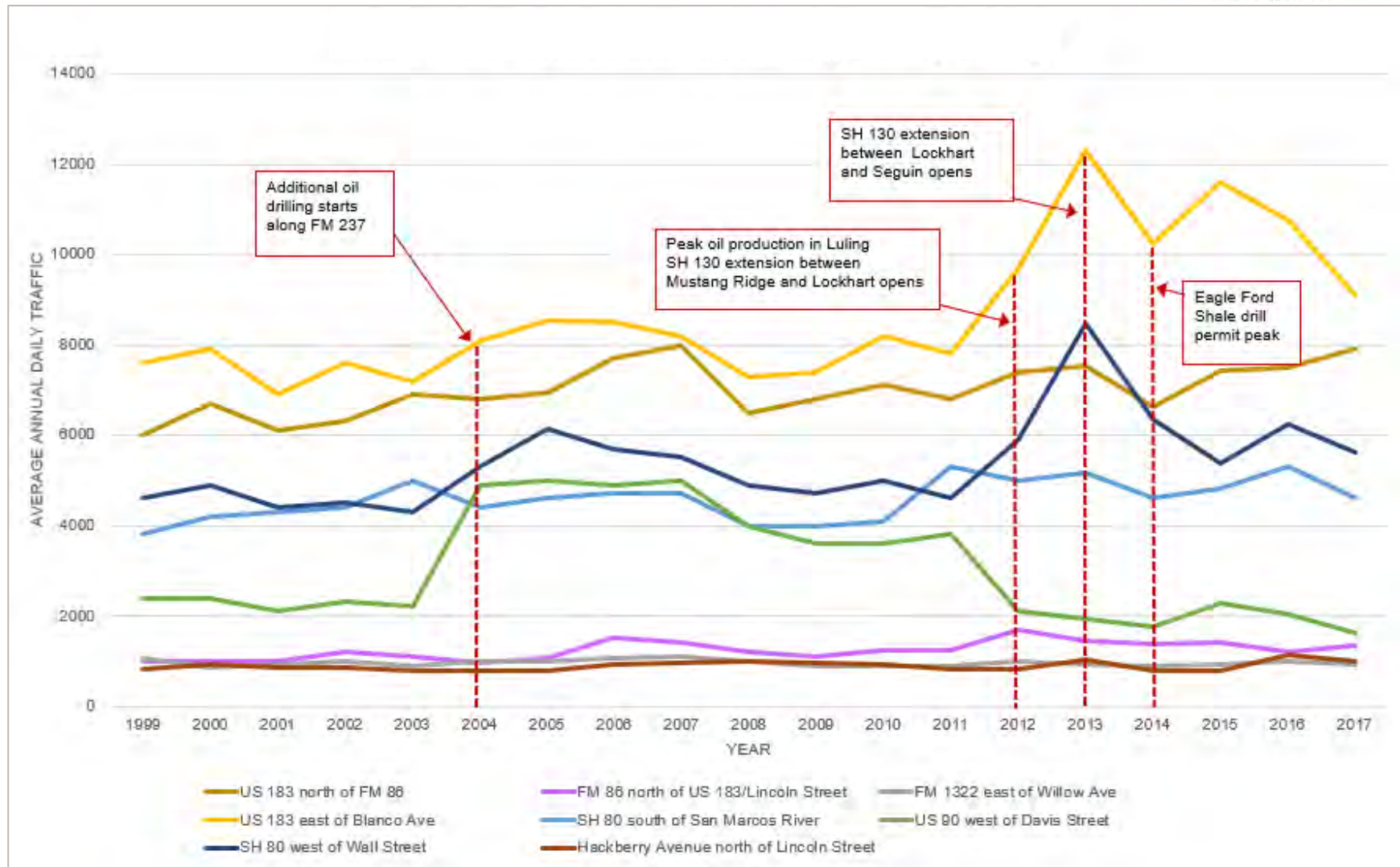

Figure 3 - Historic Counts Entering/Exiting Luling (use with Figure 2)



Table 2 - Thursday/Friday PM Peak Hour Volumes

Period Start	Thursday, September 27th						Friday, September 28th					
	SH 80 at Hackberry Avenue	US 183 & SH 80 & US 90	US 183 & SH 80	US 183 & SH 86	US 90 at Hackberry Avenue	Total (15-minutes)	SH 80 at Hackberry Avenue	US 183 & SH 80 & US 90	US 183 & SH 80	US 183 & SH 86	US 90 at Hackberry Avenue	Total (15-minutes)
16:00	241	381	346	236	179	1383	277	472	425	291	197	1662
16:15	217	351	347	254	108	1277	247	462	424	299	111	1543
16:30	189	383	348	259	98	1277	261	456	444	314	104	1579
16:45	205	368	348	253	102	1276	199	442	385	289	117	1432
17:00	178	382	333	243	108	1244	253	446	415	310	111	1535
17:15	190	378	349	266	111	1294	249	420	426	301	98	1494
17:30	191	379	345	241	104	1260	245	459	422	266	79	1471
17:45	201	344	310	200	108	1163	240	421	428	309	120	1518

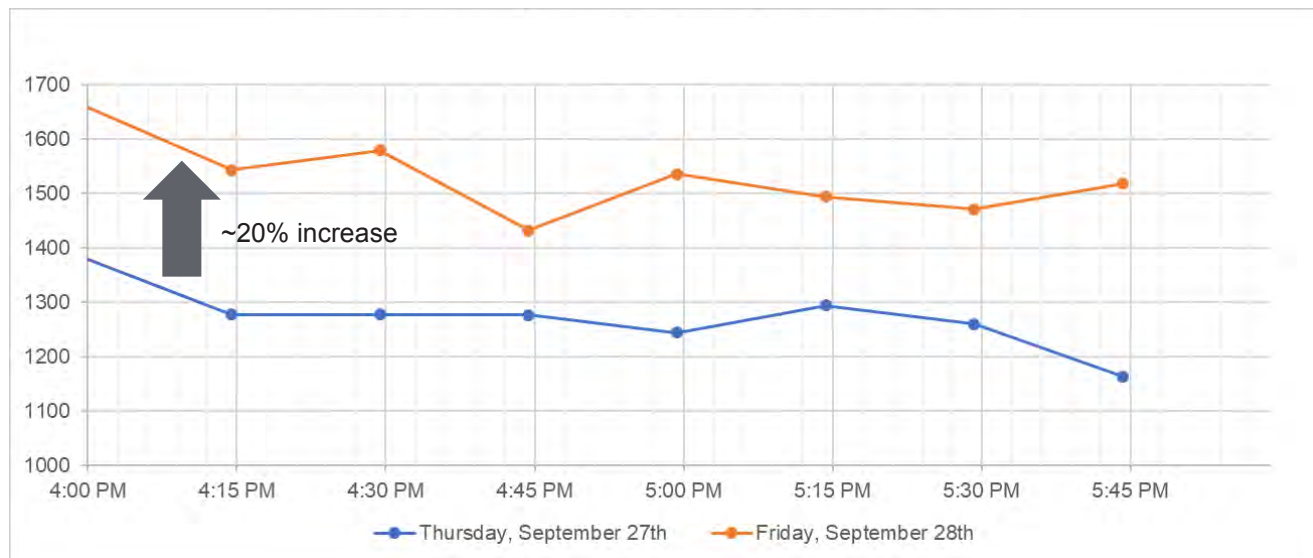

Figure 4 - Study Intersection 15-Minute Count Comparison





Figure 5 - Average Daily Traffic - 2017 (Friday Average) Total & Heavy Vehicles



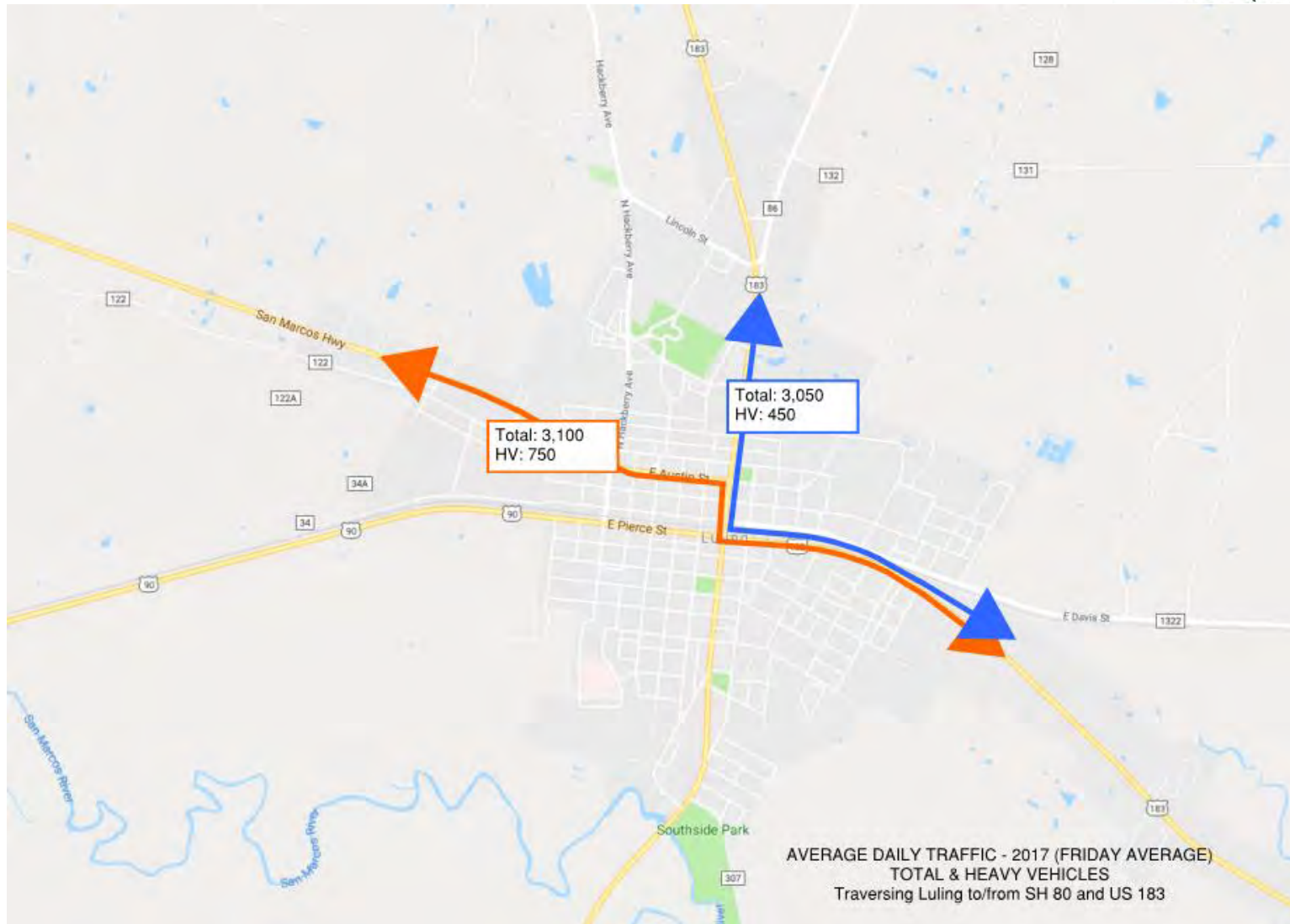

Figure 6 - Average Daily Traffic - 2017 (Friday Average) Total & Heavy Vehicles Traversing Luling to/from SH 80 and US 183



Environmental Constraints Mapping

Environmental constraints mapping is the process of identifying features related to land use, ecology, and geography that need to be considered during conceptual design and feasibility of a transportation project. Watersheds and floodplains were obtained from the Federal Emergency Management Agency (FEMA), and other sites were obtained from the Environmental Protection Agency's NEPAassist Tool. Parcel data was obtained from the Caldwell County Appraisal District. The list below provides definitions for special features contained on the map:

- Historic Sites – sites contained on the National Register of Historic Places.
- National Pollutant Discharge Elimination System – sites with federal permit to discharge pollutants into waters of the United States.
- Hazardous Waste Resource Conservation and Recovery Act Information – sites registered as having generators, transporters, treaters, storers, and disposers of hazardous waste.
- Toxic Releases Inventory – sites with toxic chemical releases and waste management activities reported annually by certain industries as well as federal facilities.
- Threatened and Endangered Species Occurrence – potential habitat of species classified as threatened or endangered by the Environmental Protection Agency.
- 100 year floodplain – land with a 1% annual chance of flood hazard.
- 500 year floodplain – land with a 0.2% annual chance of flood hazard.
- Parcels – division of property boundaries.



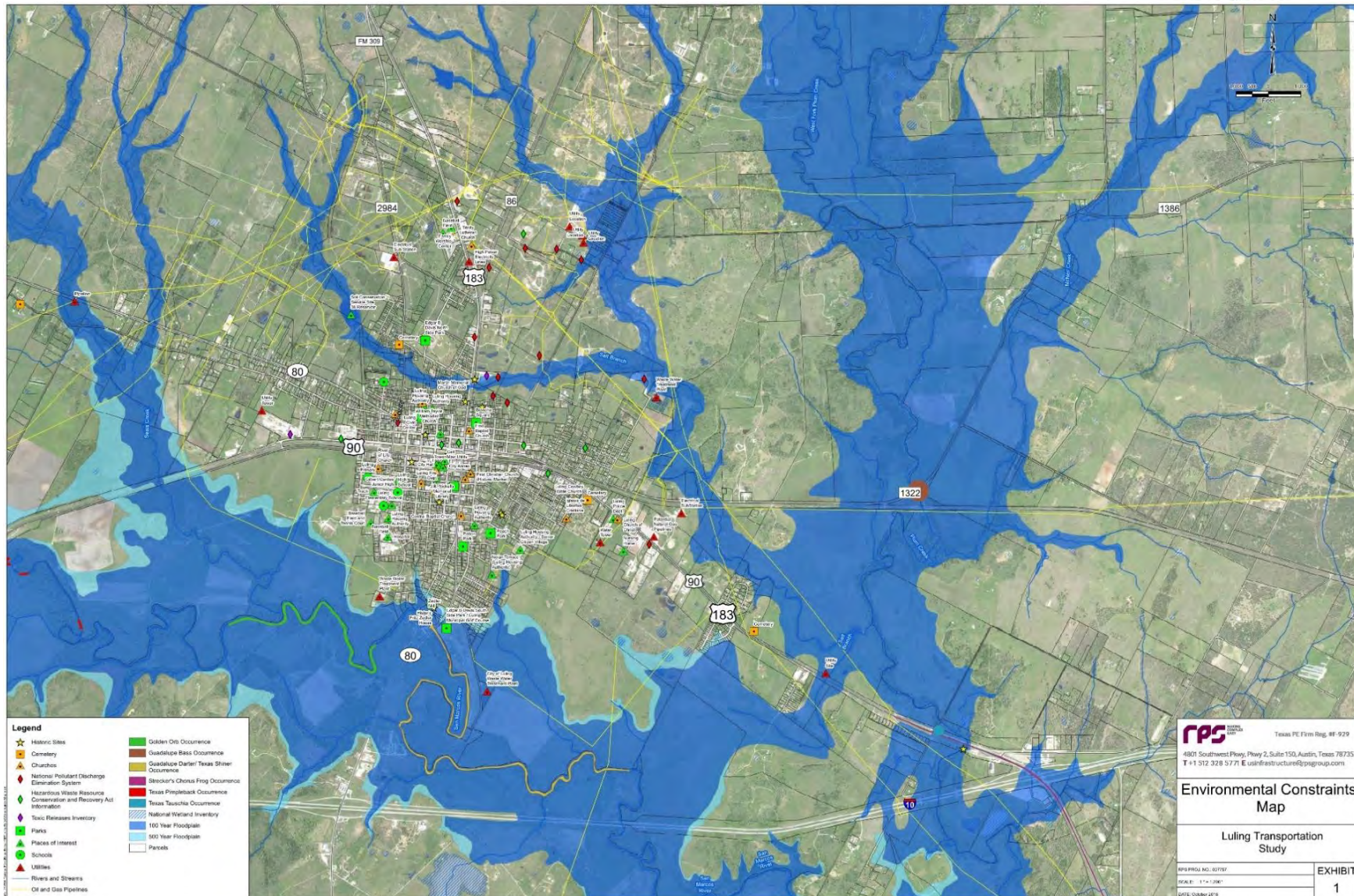

Figure 7 - Environmental Constraints Map



Performance Measures

A set of performance measures to assess potential options was developed in coordination with the project steering committee. The following table lists the four goals of the Luling Transportation Study, their associated performance measures, and the methods of calculation and data source for each measure.

Table 3 - Recommended Performance Measures

Goal	Performance Measure	Unit/Ranking	Method of Calculation	Data Source
Goal 1: Identify needed safety improvements	Predicted annual crash rates by severity	crashes/year	Highway Safety Manual (HSM) Predictive Method	<ul style="list-style-type: none"> ○ TxDOT Crash Records Information System ○ HSM crash modification factors clearinghouse ○ TxDOT Highway Safety Improvement Manual
	Presence of new or improved street crossing or walking path for pedestrians	<ul style="list-style-type: none"> ○ Number of protected crossings added in central Luling ○ Miles of sidewalk/walking paths added 	Geographic Information Systems	<ul style="list-style-type: none"> ○ City, County, and TxDOT shapefiles ○ Available aerial imagery
	Number of grade-separated (bridge) railroad crossings provided by improvements	Number of grade-separated crossings added	Geographic Information Systems	<ul style="list-style-type: none"> ○ City, County, and TxDOT shapefiles ○ Available aerial imagery
	Improvement to travel time and reliability for evacuation and emergency response travel (5-minute travel shed area)	Acres of coverage	Geographic Information Systems	<ul style="list-style-type: none"> ○ StreetLight GPS and cell phone data ○ Google maps travel time estimates ○ Turning movement counts collected in September 2018



Goal	Performance Measure	Unit/Ranking	Method of Calculation	Data Source
<p style="writing-mode: vertical-rl; transform: rotate(180deg);">Goal 2: Enhance mobility in downtown for local and through traffic</p>	<p>Estimated daily entering traffic at US 183 / SH 80 / US 90 intersection</p>	<ul style="list-style-type: none"> ○ Total entering daily traffic ○ Total entering daily traffic 	<p>Apply growth rates from CAMPO Travel Demand Model to AADT collected by TxDOT</p>	<ul style="list-style-type: none"> ○ TxDOT Traffic Count Database System ○ CAMPO Travel Demand Model
	<p>Estimated average travel time for typical Friday PM peak hour conditions</p>	<p>minutes</p>	<p>Use StreetLight data to set existing baseline for travel time. Use Synchro outputs to determine increase/decrease.</p>	<ul style="list-style-type: none"> ○ StreetLight GPS and cell phone data ○ Turning movement counts collected in September 2018
	<p>Intersection level of service (LOS) for typical weekday and typical Friday PM peak hour conditions</p>	<ul style="list-style-type: none"> ○ LOS (A – F) ○ Average delay/vehicle 	<ul style="list-style-type: none"> ○ Synchro ○ Highway Capacity Manual 	<ul style="list-style-type: none"> ○ Turning movement counts collected in September 2018
	<p>Average railroad crossing delay for typical weekday and typical Friday PM peak hour conditions</p>	<ul style="list-style-type: none"> ○ Daily Vehicle hours of delay at US 183 and Hackberry crossings ○ Friday PM peak vehicle hours of delay at US 183 and Hackberry crossings 	<p>Use StreetLight data to set existing baseline for railroad delay. Use Synchro outputs to determine increase/decrease.</p>	<ul style="list-style-type: none"> ○ StreetLight GPS and cell phone data ○ Turning movement counts collected in September 2018





Goal	Performance Measure	Unit/Ranking	Method of Calculation	Data Source
<p style="writing-mode: vertical-rl; transform: rotate(180deg);">Goal 3: Evaluate feasibility of an alternate route for through traffic</p>	<p>Estimated cost of each alternative including design, environmental compliance, right-of-way, and construction</p>	<p>Million \$</p>	<p>Generalized unit cost and quantities</p>	<p>Recent unit costs for Caldwell County, City of Luling, or TxDOT Austin District</p>
	<p>Environmental impacts in terms of network fuel consumption and greenhouse gas emissions (PM peak hour)</p>	<ul style="list-style-type: none"> o Gallons fuel consumed o Kilograms carbon monoxide emitted 	<ul style="list-style-type: none"> o Synchro o Highway Capacity Manual 	<ul style="list-style-type: none"> o Turning movement counts collected in September 2018 o EPA Greenhouse Gas Equivalencies Calculator
	<p>Overall environmental suitability of improvements (floodplains, land use, cultural resources, etc.)</p>	<p>Level of suitability 1 = low, many conflicts 2 = medium, some conflicts 3 = high, few conflicts</p>	<p>Qualitative, with Geographic Information Systems mapping</p>	<p>Shapefiles from City, County, TxDOT, FEMA, and Texas Parks and Wildlife Department (TPWD) shapefiles</p>



Goal	Performance Measure	Unit/Ranking	Method of Calculation	Data Source
<p>Goal 4: Promote the unique character of downtown and economic development opportunities</p>	<p>Increase or decrease in number of automobiles and trucks passing downtown through US 183 / SH 80 / US 90 intersection; distinguish trips that stop in downtown from pass-through trips</p>	<ul style="list-style-type: none"> ○ Total AADT <ul style="list-style-type: none"> ○ Local to Luling ○ Pass-through Luling ○ Daily heavy truck traffic <ul style="list-style-type: none"> ○ Local to Luling ○ Pass-through Luling 	<p>Apply growth rates from CAMPO Travel Demand Model to AADT collected by TxDOT. Estimate likely traffic diversion with consideration to pass-through activity levels in StreetLight data.</p>	<ul style="list-style-type: none"> ○ TxDOT Traffic Count Database System ○ CAMPO Travel Demand Model ○ StreetLight GPS and cell phone data
	<p>Improvement to main street connectivity along US 183 / Davis Street and US 183 / SH 80 / US 90 intersection</p>	<ul style="list-style-type: none"> ○ Number of protected crossings added in central Luling ○ Miles of sidewalk/walking paths added 	<p>Qualitative</p>	<p>Qualitative</p>



Short-Term Improvement Options – Elements and Rough Order of Magnitude



Existing at Magnolia Ave./Pierce St.

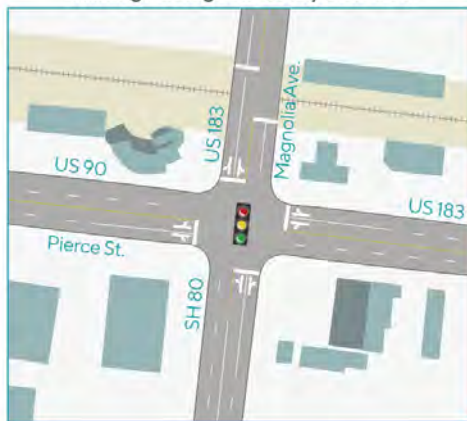

Proposed at Magnolia Ave./Pierce St.

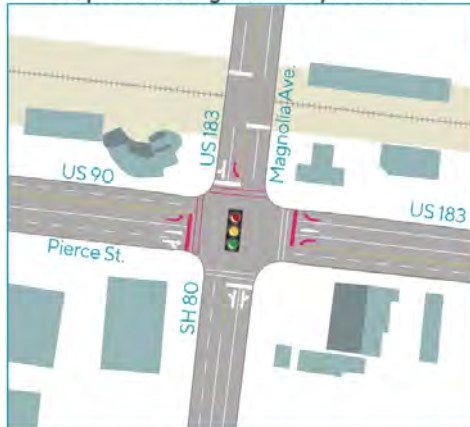

**Table 4 – Short-Term Improvements
Rough Order of Magnitude**

#	Item	Cost Range (thousand \$)
Hackberry Improvements		
1	Two new signals at SH 80 and US 90 with controller, mast arms, striping, and curb ramps. TxDOT standards.	500
2	Repave 50 ksf of street (1000' long x 50' wide)- mill & overlay	125 - 250
3	Striping for centerline and intersection approaches	50
4	Construct 15 ksf of sidewalks (3000' long x 5' wide) within existing ROW	150
5	Advance warning and truck route signage on SH 80 EB and US 90 / US 183 WB	25
	Subtotal	\$850 - 975
Magnolia / Pierce (US 183 / SH 80 / US 90) Improvements		
6	Restripe dedicated turn pockets and crosswalks	30
7	Signal head modifications (EB and WB approaches, only) and added crosswalk countdown timers	20 - 70
8	250 sf ROW on NW corner to improve WBR turn radii for large trucks (land values estimated from Caldwell CAD)	5 - 10
9	Reconstruct 4 curb ramps with widened WBR turn radii	40 - 60
10	Construct 2.5 ksf of sidewalks (500' long x 5' wide) within existing ROW	25
11	Relocate signal mast arm and gas station sign (NE corner)	5
	Subtotal	\$125 - 200
Additional Studies		
12	Neighborhood traffic calming study	50
13	Safe routes to school plan	50
14	Four-way stop-sign evaluation at Walnut Avenue / Pierce Street intersection	5 - 15
	Subtotal	\$105 - 115
	TOTAL	\$1,180 - 1,290



Long-Term Improvement Options – Elements and Rough Order of Magnitude

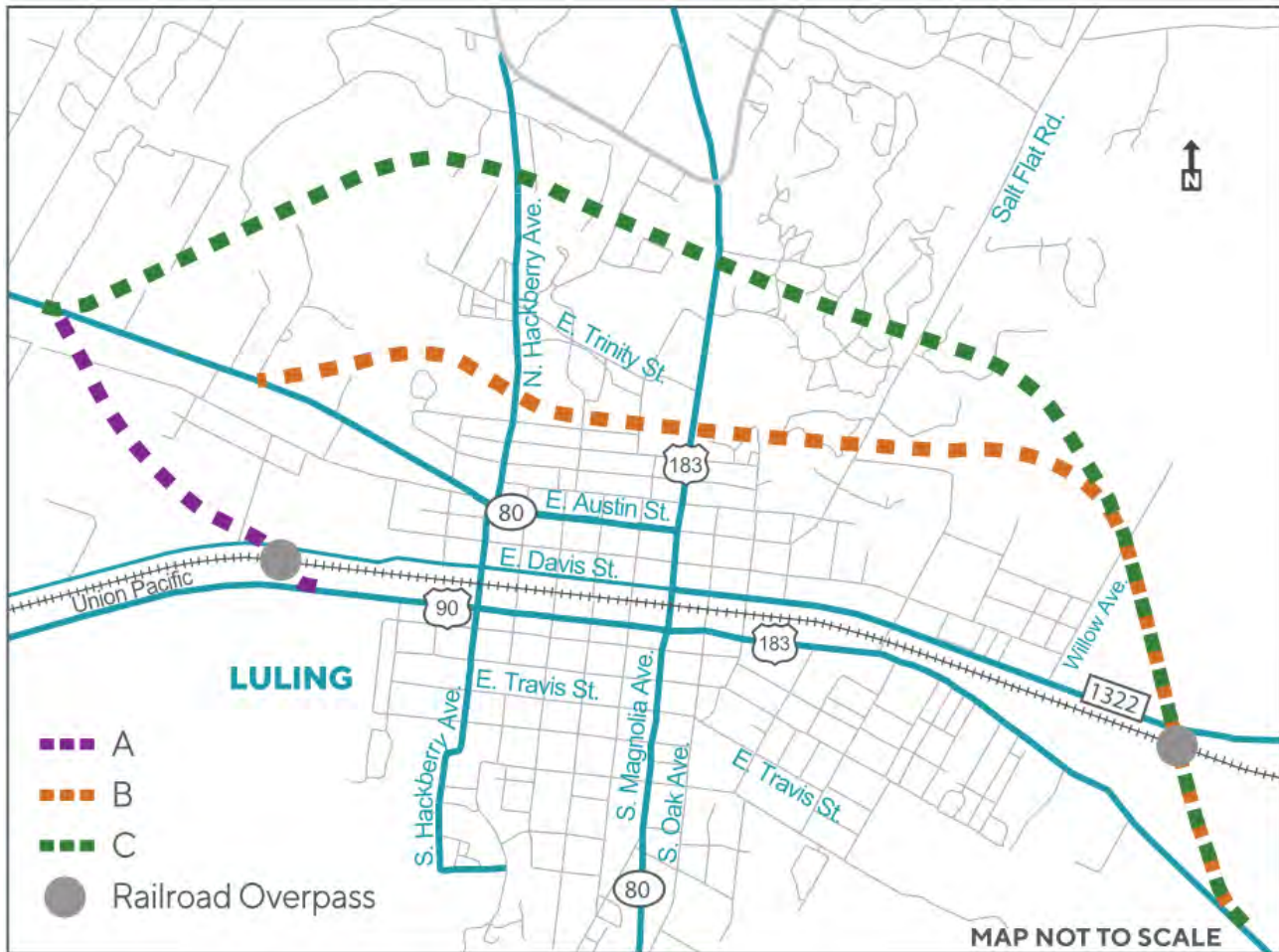

Table 5 – Option A – Rough Order of Magnitude

#	Item	Cost Range (thousand \$)
1	New two-lane roadway with approximately 100' cross-section (12' lanes, 10' shoulders, 28' clear zone/drainage each direction) – variable alignments 0.8 – 1.2 miles	3,500 – 5,200
2	ROW, 12 – 15 acres (land values estimated from Caldwell CAD)	850 – 1,050
3	Side-street stop-controlled intersection at new alignment intersection with SH 80, with channelized EBR turn	200
4	500' span bridge over Davis Street, UPRR, and US 90 (eastbound connector)	2,000 – 3,000
5	500' add lane on US 90 westbound for WB to NB connection; 500' drop lane on US 90 eastbound for SB to EB connection	200 - 400
6	Advance warning and truck route signage on SH 80 EB and US 90 / US 183 WB	50
TOTAL		\$6,800 – 9,900



Table 6 – Option B – Rough Order of Magnitude

#	Item	Cost Range (thousand \$)
1	New two-lane roadway with approximately 100' cross-section (12' lanes, 10' shoulders, 28' clear zone/drainage each direction) – variable alignments 3.5 – 4.0 miles	15,000 – 17,500
2	ROW, 35 – 40 acres (land values estimated from Caldwell CAD)	2,500 – 2,800
3	Side-street stop-controlled intersection at new alignment intersection with SH 80, with channelized EBR turn. Includes advance warning and truck route signage.	200
4	Side-street stop-controlled intersection at new alignment intersection with Hackberry. Includes advance warning and truck route signage.	200
5	New signalized intersection at new alignment intersection with US 183 north of Austin Street. TxDOT standards. Includes advance warning and truck route signage.	500 - 1000
6	500' span bridge over FM 1322 and UPRR	2,000 – 3,000
7	New signalized intersection at new alignment intersection with US 183 east of Blanco Avenue. TxDOT standards. Includes advance warning and truck route signage.	500
TOTAL		\$20,900 – 25,200

Table 7 – Option C – Rough Order of Magnitude

#	Item	Cost Range (thousand \$)
1	New two-lane roadway with approximately 100' cross-section (12' lanes, 10' shoulders, 28' clear zone/drainage each direction) – variable alignments 4.0 – 4.5 miles	17,500 – 20,000
2	ROW, 40 – 45 acres (land values estimated from Caldwell CAD)	2,800 – 3,150
3	Side-street stop-controlled intersection at new alignment intersection with SH 80, with channelized EBR turn. Includes advance warning and truck route signage.	200
4	Side-street stop-controlled intersection at new alignment intersection with Hackberry. Includes advance warning and truck route signage.	200
5	New signalized intersection at new alignment intersection with US 183 north of Austin Street. TxDOT standards. Includes advance warning and truck route signage.	500 – 1000
6	500' span bridge over FM 1322 and UPRR	2,000 – 3,000
7	New signalized intersection at new alignment intersection with US 183 east of Blanco Avenue. TxDOT standards. Includes advance warning and truck route signage.	500
8	Two bridges over Salt Branch (assume each 500' span)	4,000 – 6,000
TOTAL		\$27,700 – 34,050



Improvement Options – Performance Measurement

A performance measures matrix was created to visually convey how each option compares to the existing conditions and 2045 no build conditions, as well as to each other. The performance measures were calculated using the methods and data sources described in **Table 8** the data for each measure based on the condition of the study area. “High” and “low” traffic growth scenario were analyzed to account for uncertainty and to create a range of performance.

Generating “High” and “Low” Traffic Forecasts

The project team recognizes that there is not a clear indication of how transportation conditions will change through Luling over the next 25 years. The oil boom ended several years ago, so some of the historical data indicates that traffic and truck growth will proceed at the moderate rates observed during much of the last 20 years. However, it could be argued that the oil market is cyclical, and new production technologies or increase in domestic/global demand could result in more booms like the one experienced between 2011 and 2014.

Several data sources and traffic models were reviewed to determine a potential range of growth rates (low and high):

- *Historical traffic counts from TxDOT Traffic Count Database System (TCDS)*– for locations with two or more years of available AADT data, a logarithmic (trendline) growth rate was calculated. All study location had data spanning 1999 – 2019.
- *CAMPO 2040 Regional Transportation Plan (RTP) Model* – CAMPO maintains a regional transportation plan model for long range traffic forecasting. CAMPO provided directional ADT and peak hour volume outputs for the City of Luling for years 2010 and 2040. Growth rates between these two years were calculated for each approaching/departing roadway.

Growth rates were averaged for eight approach/departure roadways. The average growth rate for the TCDS historical data is 1%, and the average growth rate for the CAMPO RTP model outputs is 2.7%. The TCDS growth rate accounts for nearly 20 years of variation in traffic volumes, including the emergence and dissipation of the oil boom between 2011 and 2014. The CAMPO RTP model may have somewhat higher growth rates than the TCDS counts due to the expectation that population and employment growth in Caldwell County will begin to pick up as the areas surrounding Austin continue to develop. To capture a range of potential traffic growth scenarios, the 1% annual growth rate from the TCDS was assumed as a “low” scenario and the 2.7% CAMPO RTP rate as a “high” scenario.



Table 8 - Performance Measures Matrix

Goal	Measure	Unit	Existing	No Build		Near-Term Improvements		Option A		Option B/C	
				Low	High	Low	High	Low	High	Low	High
1	Predicted annual crash rates by severity	crash/yr	22	30	41	27	39	26	36	27	36
	Presence of new or improved street crossing or walking path for pedestrians	Number of protected crossings added in Central Luling	0	0	10	0	0	0	0		
		Miles of sidewalk/walking paths added	0	0	0.6	0	0	0			
	Number of at-grade and grade separated railroad crossings provided by improvements	Number of grade-separated crossings (bridges over rail) added	0	0	0	1	1				
	Improvement to travel time and reliability for evacuation and emergency response travel (5-minute travel shed area)	Acres of coverage	1892	823	2068	2169	2194				
2	Estimated daily entering traffic at US 183/ SH 80 /US 90 intersection	Total entering daily traffic	18500	23500	32100	23500	32100	23500	32100	18550	25300
		Total entering daily trucks	1600	2100	2850	2100	2850	2100	2850	700	900
	Estimated Friday PM travel time for automobiles (seconds)	SH 80 EB from Scenic View Drive to US 183 EB at Oakview Rd	9	11	17	6	7	4	5	6	6
		US 183 SB at FM 309 to US 183 EB at Oakview Rd	9	10	14	9	9	9	9	6	6
		US 183 WB at Oakview Rd to SH 80 WB at Scenic View Drive	9	13	21	7	8	6	6	6	6
		US 183 NB at Oakview Rd to US 183 NB at FM 309	8	12	20	6	7	6	7	6	6
		Intersection level of service (LOS) for typical Friday PM peak hour conditions	US 183 / SH 80	B	B	E	B	C	B	C	B
		US 183 / SH 80 / US 90	F	F	F	C	D	C	D	C	C
		Hackberry / SH 80	A	B	F	B	C	A	D	A	E
		Hackberry / US 90	A	B	F	A	B	A	A	B	F
	Intersection average delay for typical Friday PM peak hour conditions (seconds)	US 183 / SH 80	13	19	78	11	26	11	23	12	22
		US 183 / SH 80 / US 90	109	257	554	25	50	25	50	20	31
		Hackberry / SH 80	4	12	995	16	26	6	31	6	43
		Hackberry / US 90	8	13	145	9	13	7	9	13	145
		Total railroad crossing delay for typical weekday and typical Friday PM peak hour conditions	Daily vehicle hours of delay at US 183 crossing	104	135	193	131	185	110	156	99
	Friday PM peak vehicle hours of delay at US 183 crossing		16	21	32	21	32	18	26	16	24



LULING TRANSPORTATION STUDY

RESULTS SUMMARY – APRIL 2019



Goal	Measure	Unit	Existing	No Build		Near-Term Improvements		Option A		Option B/C		
				Low	High	Low	High	Low	High	Low	High	
3	Estimated cost of each alternative including design, environmental compliance, right-of-way, and construction	Million \$	n/a	n/a	n/a	1.2	1.3	7	10	21	34	
	Environmental impacts in terms of network fuel consumption and greenhouse gas emissions (Friday PM peak hour)	Gallons of fuel consumed	143	242	910	160	285	150	273	164	312	
		kg CO emissions	9.97	16.92	63.6	11.19	19.92	10.47	19.06	11.47	21.82	
	Overall environmental suitability of improvements (floodplains, land use, cultural resources, etc.)	1= low, many conflicts, 2=medium some conflicts, 3 = high, few conflicts	-	-	-	High	High	Med	Med	Low	Low	
4	Total AADT		18500	23500	32100	23500	32100	23500	32100	18550	25300	
	AADT Local to Luling		10900	14400	16400	14400	16400	14400	16400	14400	16400	
	AADT Pass-through Luling		7600	9100	15700	9100	15700	9100	15700	4150	8900	
	Total AADT compared to No Build		n/a	n/a	n/a	0	0	0	0	-4950	-6800	
	Increase or decrease in number of automobiles and trucks passing downtown through US 183 / SH 80 / US 90 intersection; distinguish trips that stop in downtown from pass-through trips	Total Heavy Trucks		1600	2100	2850	2100	2850	2100	2850	900	1200
		Total Heavy Truck Local to Luling		150	350	450	350	450	350	450	350	450
		Total Heavy Truck Pass-through Luling		1450	1750	2400	1750	2400	1750	2400	550	750
		Heavy Truck volume compared to No Build		n/a	n/a	n/a	0	0	0	0	-1200	-1650
	Improvement to pedestrian connectivity between US 183 / Davis Street and US 183 / US 90 intersections	Number of protected crossings added		n/a	0		2		0		0	
Miles of sidewalk/walking paths added			n/a	0		0.1		0		0		



Public Survey – Results Summary

A community survey was developed in both English and Spanish and was administered between January 13, 2019 and February 24, 2019. The purpose of this survey was to determine people’s perception of transportation conditions and issues within Luling and gauge opinions of the Luling Transportation Study Goals. In total, 252 responses were completed. Detailed results are contained within the Community Summary Survey Document. Overall, more than 70% of respondent agreed with the goals of the study. Other major findings and a sampling of written comments from the survey are provided below.

Community Concerns as Percentages

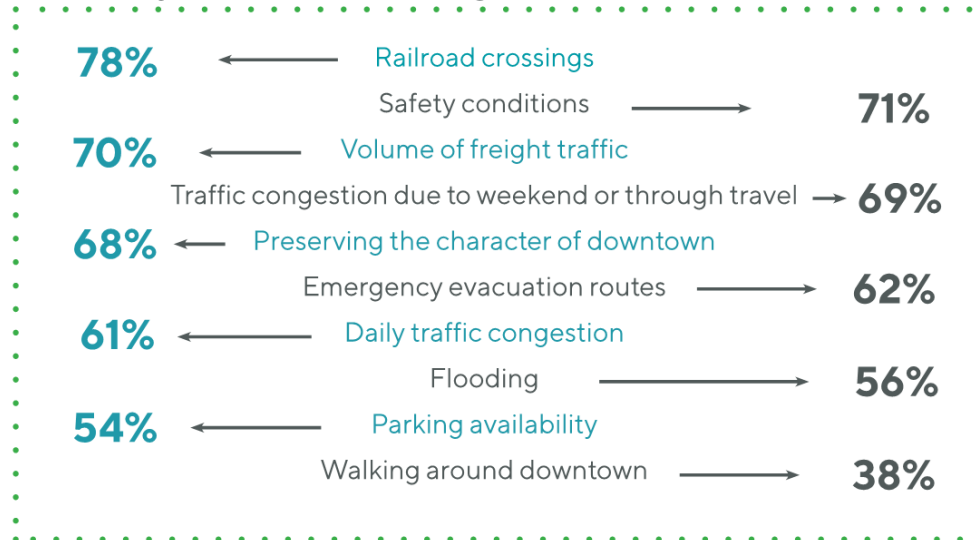

Schedule and Next Steps



The project team is currently evaluating community input on the short- and long-term options. The public comment period is open now and will be closed on May 15, 2019. Those comments and the materials contained within this document will be used to determine the recommended short- and long-term solutions and to finalize the report in summer 2019.

Other steps remaining in the study process include:

- Present recommendations to Luling City Council, Caldwell County Commissioners Court, and the CAMPO Transportation Policy Board
- Include recommended projects in CAMPO plans
- Secure funding for near-term improvements
- Complete the environmental study, design, and engineering for near-term improvements
- Evaluate travel and consider when long-term improvements are needed



LULING

TRANSPORTATION STUDY

Community Survey Summary

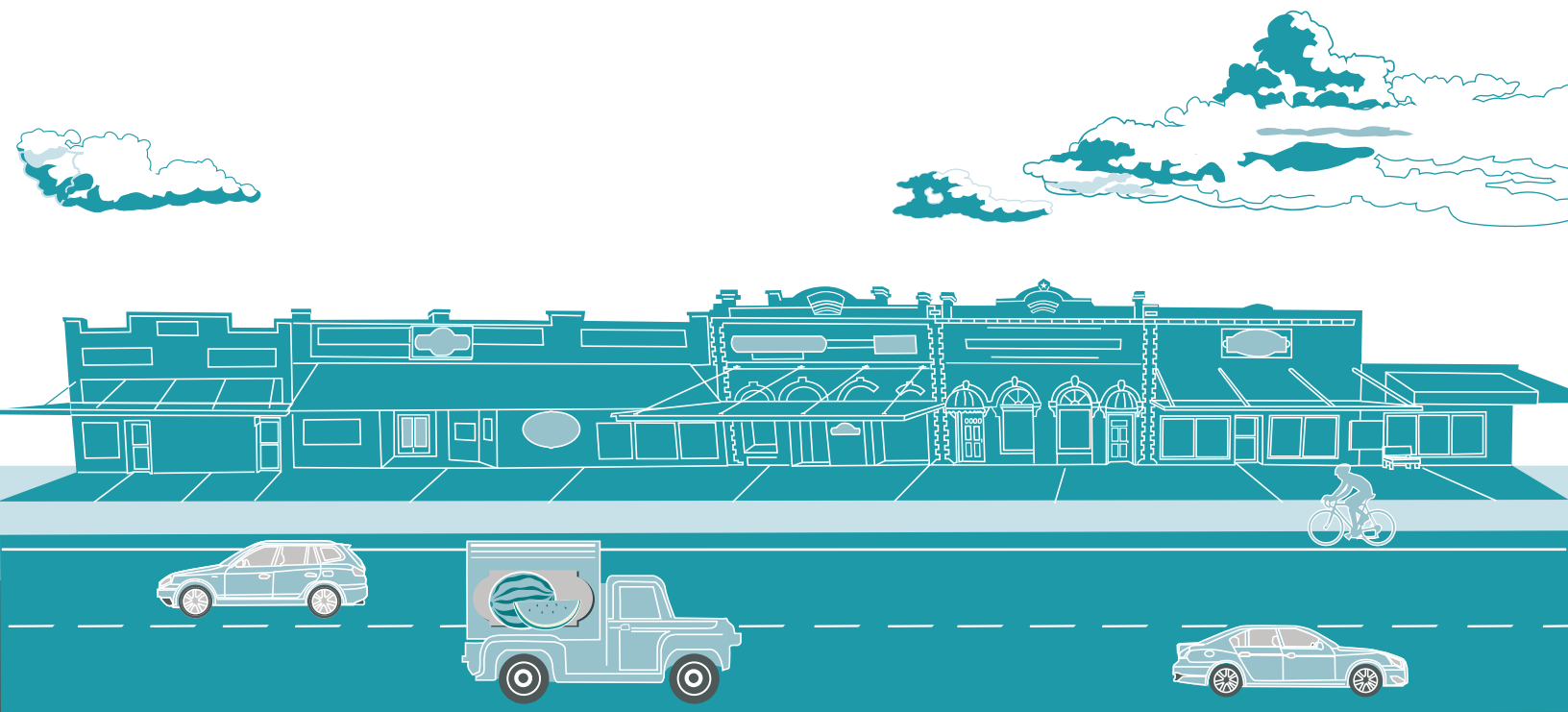

What We Heard

Community Survey

The community survey was developed in English and Spanish and was available online and in print from **January 13, 2019 to February 24, 2019**. Printed copies were available at several community events and distributed to community partners to share with postage-paid return envelopes. **243 English responses and 9 Spanish responses were completed.**

Survey Response Summary

Do you prefer to respond to this survey in English or Spanish? (25 answered, 27 skipped)

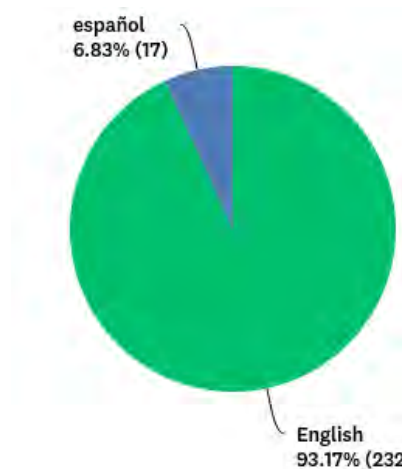

What We Heard

Survey Response Summary

Please share your input on transportation in Luling. How concerned are you with:

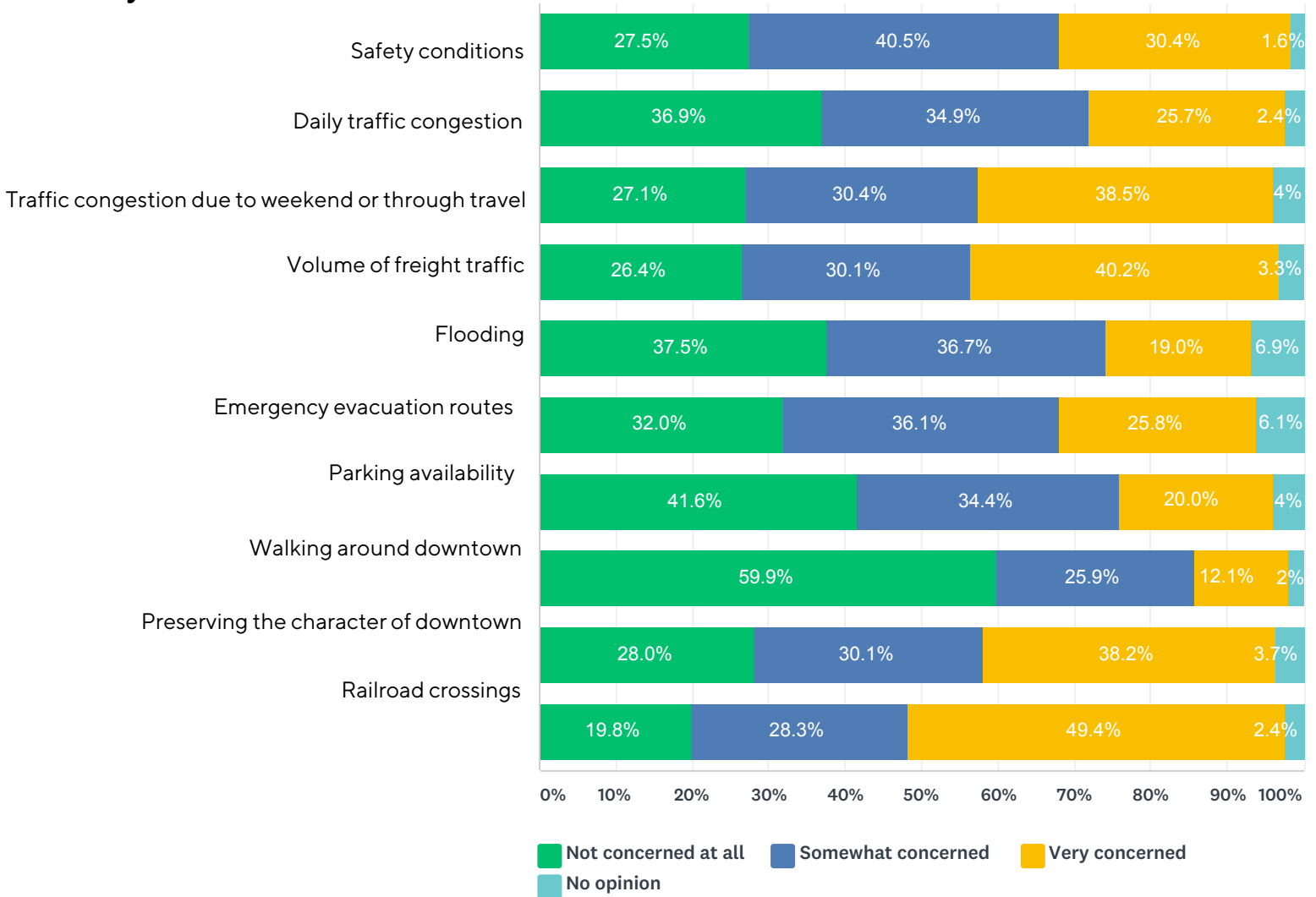

What brings you to Luling? (select all that apply)

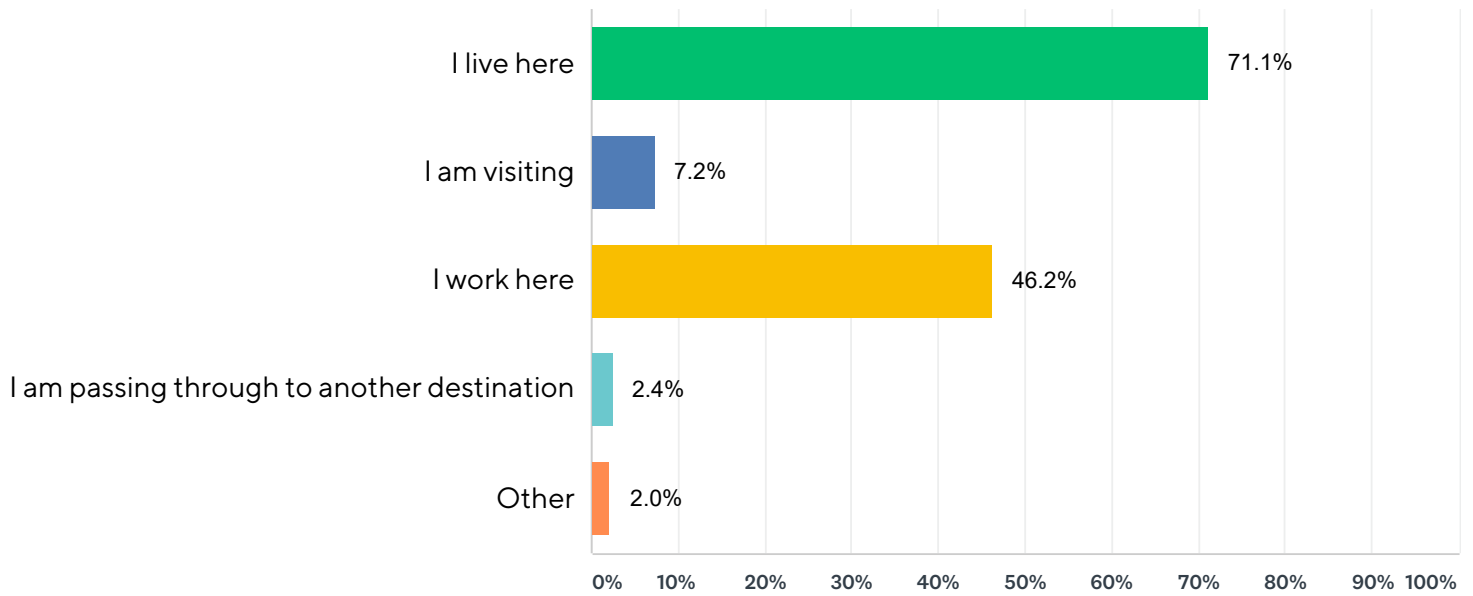

Zip Code	Responses
78648	8
78666	6
78629	6
78155	6
78644	4
78640	4
78130	4
78632	3
78616	3
78744	2
78731	2
78638	2
78622	2
78612	2
78239	2
78764	1
78759	1
78757	1
78660	1
78602	1
78244	1
78109	1
78102	1
77006	1
77539	1

Destination	Responses
Recreation, shopping, dining	5
School	4
Church	2
Austin	2
San Antonio	2
Gonzales	1
Wimberly	1

Frequency	Responses
Daily	10
4-6 times a week	22
1-3 times a week	7
3 times a month	4
1-2 times a month	6
1-2 times a year	4

Do you agree with the study goals?

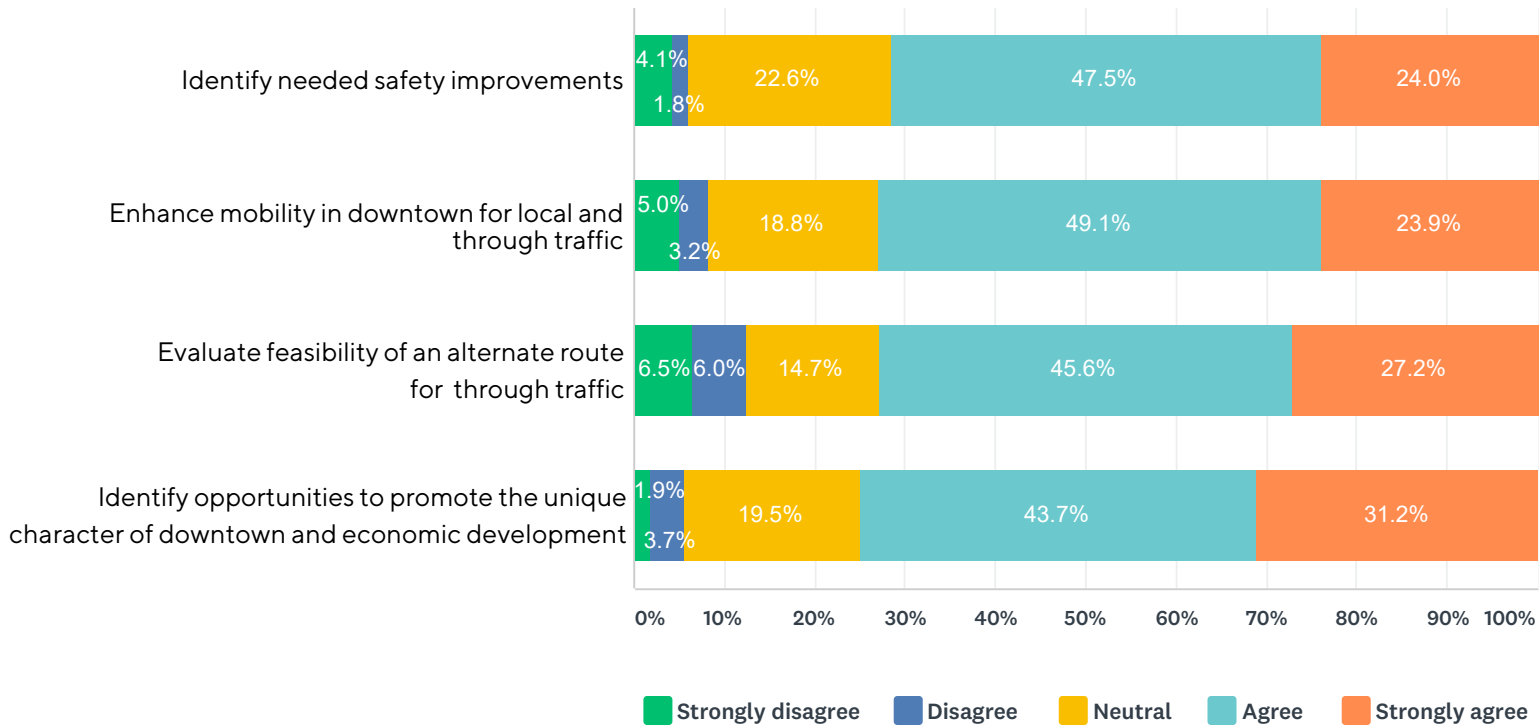

Do you have any additional comments on transportation in Luling?

Common themes:

- Potholes and need for road maintenance
- Concern for freight traffic damaging roads
- Improved pedestrian safety and additional pedestrian crossings
- Improved access for emergency services
- Improved traffic signal timing
- Increased public transportation options
- Speeding concerns
- Opposition to building alternate route

What We Heard

Survey Response Summary - English

Please share your input on transportation in Luling. How concerned are you with:

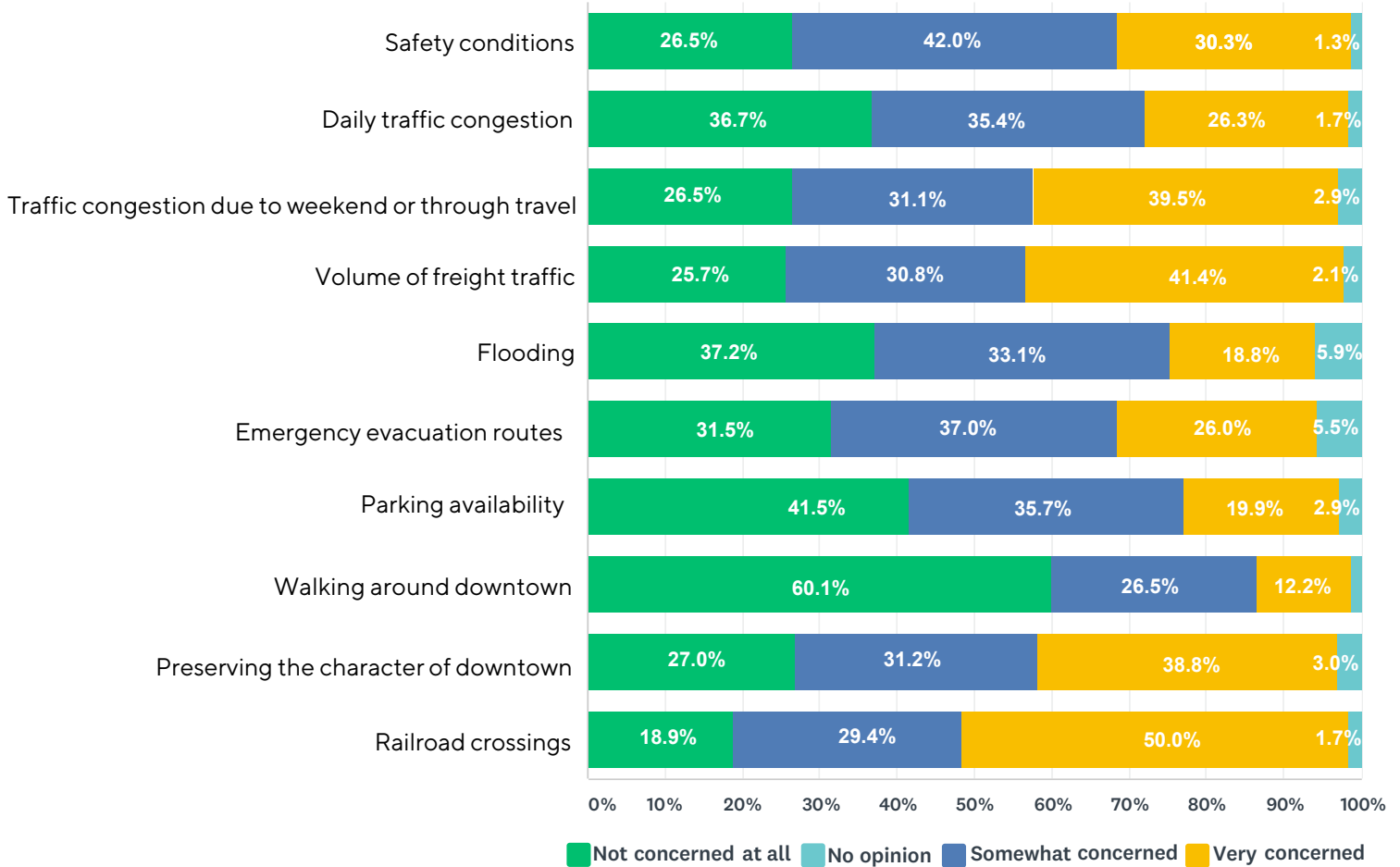

What brings you to Luling? (select all that apply)

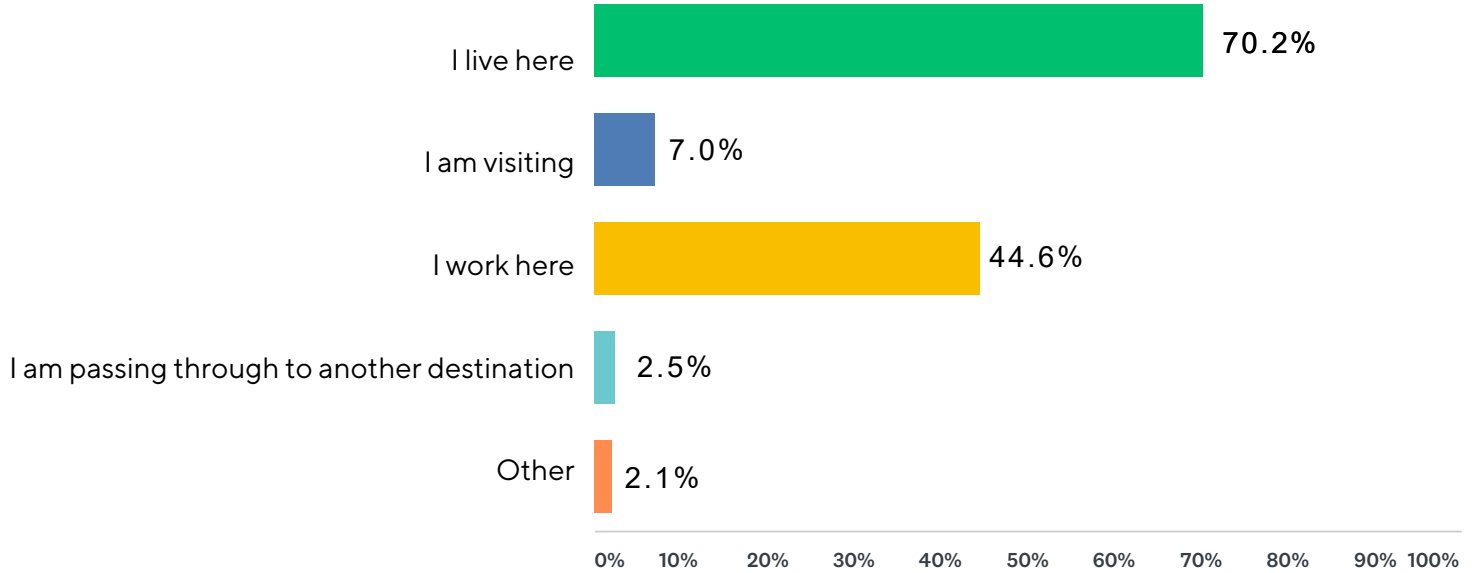

Zip Code	Responses
78648	8
78666	6
78629	6
78155	6
78644	4
78640	4
78130	4
78632	3
78616	3
78744	2
78731	2
78638	2
78622	2
78612	2
78239	2
78764	1
78759	1
78757	1
78660	1
78602	1
78244	1
78109	1
78102	1
77006	1
77539	1

Destination	Responses
Recreation, shopping, dining	5
School	4
Church	2
Austin	2
San Antonio	2
Gonzales	1
Wimberly	1

Frequency	Responses
Daily	10
4-6 times a week	22
1-3 times a week	7
3 times a month	4
1-2 times a month	6
1-2 times a year	4

Do you agree with the study goals?

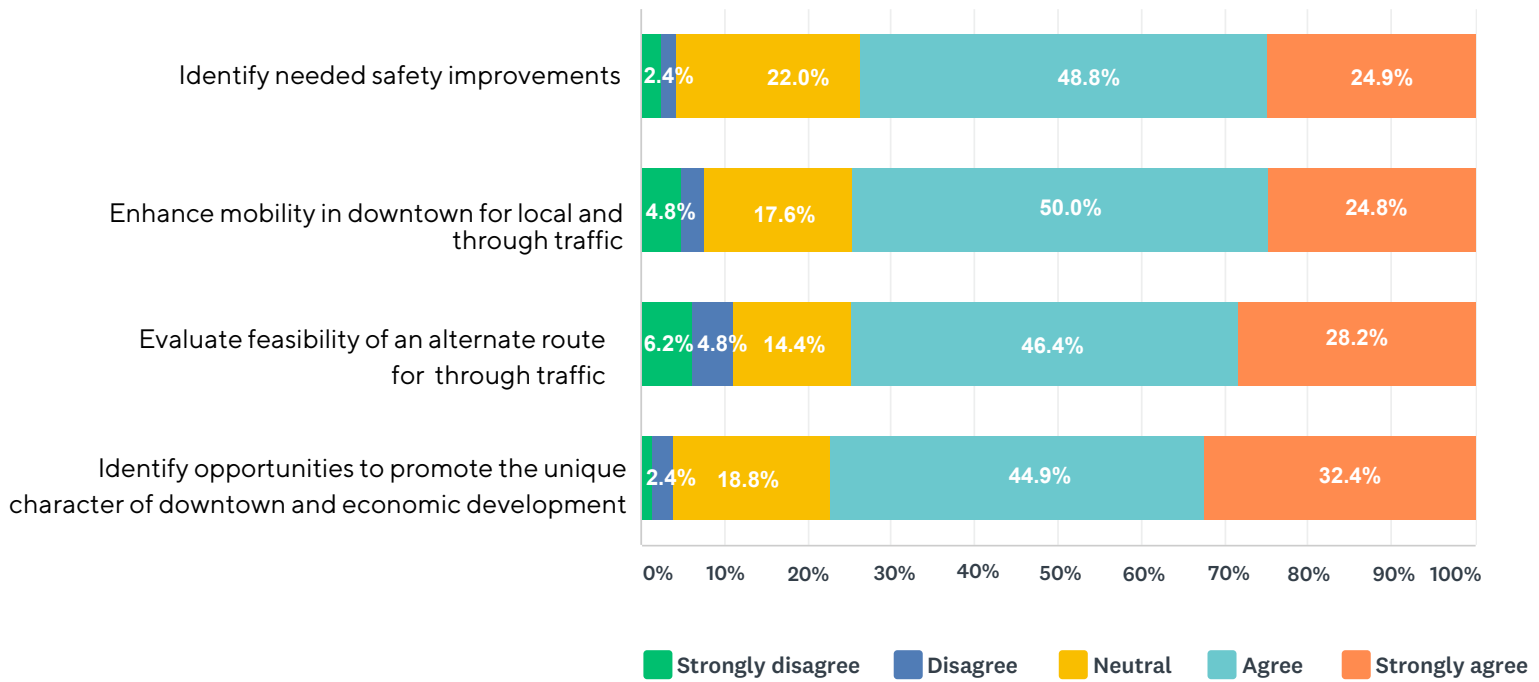

Do you have any additional comments on transportation in Luling?

Common themes:

- Potholes and need for road maintenance
- Concern for freight traffic damaging roads
- Improved pedestrian safety and additional pedestrian crossings
- Improved access for emergency services
- Improved traffic signal timing
- Increased public transportation options
- Speeding concerns
- Opposition to building alternate route

Open-Ended Responses

road improvement needed

I feel that the students of Luling ISD need to be encouraged & controlled more in regards to the safety precautions of driving through the district. They speed. They do not get tickets and the administration does not do enough to hold them accountable.

Pedestrian crossings need push buttons

Traffic doesn't concern me. The many potholes do. Fix our streets. Traffic is good for business!!!

I believe that the road damage along where the railroad tracks are located should be fixed

It concerns me when our first responders can't get across tracks when there is a train

Specific areas of concern are on Hackberry Road between Hwy 80 & Hwy 90; it's in very poor condition and highly used by local and freight vehicles. Another area is pedestrians and traffic crossing at the intersection of Hwy 183 & Davis St. Big Positive- timed lights at 183/90 & 183/80 are excellent! Not pertaining to downtown Luling, but the 2 lane Hwy on 80 b/w Luling and San Marcos caused ridiculous and unnecessary backups. (needs to go back to 4 lanes!)

There needs to be a pedestrian crosswalk sign, markings, etc. On the intersection of Davis and Magnolia.

More school zones for kids going/leaving school- morning walker and afternoon walkers

It would be nice to have police officer watching the speed on bowie and walnut or put school zone signs. A lot of drivers speed thru and there are kids crossing or high school students driving crazy.

To have more security in school or police officers driving around so there won't be much speeding or kids fighting. Putting more school zone lights. Better streets and parking spaces.

Alternate truck route in school zone and Hackberry St. Reinforce school zone areas
Maintenance on truck route roads

Bus routes should have certain intersections for them. Hackberry roads need major fixing. Possibly widening the roads, bike lane is needed. We need more crosswalk guards or patrolling from local enforcement. Speed bumps in school zones. Bring back the safety gates they used to have in school areas.

Need more sidewalks and better roads.

I was born and raised here in Luling, Tx. I love this town! But threw commercial trucks such as 18 wheelers affect our roads a lot and my car is beat up from roads being ruined from big trucks.

The information center is a waste of our tax dollars, there is never a breathing human there. We need the streets with large pot holes and road cave in's properly fixed. The streets are causing vehicle issues and accidents

There should be at least one way for people on the opposite side of the tracks from the hospital to access the hospital in case of emergency.

More sidewalks. People have to walk in the street - more crosswalks.

While attempting to preserve the "small-town feel", Luling has hindered its residents with the minimal routes available in the town. I believe that additional routes, along w/ the businesses that accompany them (gas stations/stores) would enhance the quality of life & draw increased prospects of other people moving to Luling.

My car has been vandalized in the school parking lot :(

There needs to be a pedestrian/bicycle overpass to connect the neighborhood north of the railroad to the area of the Luling schools, hospital, community health clinic, post office, & main grocery store. My main concern is solely of students crossing the main streets & railroad to get to school or walk home from school.

I am concerned about the lack of pedestrian crosswalks, especially for students needing to cross the railroad tracks walking to & from school. Also, the crosswalks, or lack thereof, are an issue when the HS releases students for lunch.
Time the green lights longer
To many pot holes! Austin St., Hackberry, the alley beside the old laundry mat as if you are going to turn back onto Hackberry St. Rough railroad crossings.
Roads in the neighborhood could use a touch up. Rough around the railroad tracks.
It would be nice to have the potholes in the road patched up
Any way to get around RR
Luling needs a more reliable dedicated public transportation with longer hours.
more reliable public transportation - getting people to doctor, grocery, pharmacy, etc. The intersection @ Magnolia + 90 carries great volume, especially when commercial traffic is mixed in with the train! What can be done to relieve this congestion?
Free or cheap transportation for those without it. An over or underpass for emergency vehicles to cross railroad tracks (Northside)
Close RR crossing on Oak Street block.
I am very satisfied with Luling citizen 30 years. Thank you Luling
Signaled crosswalks @/to NW Corner E Pierce + Magnolia.
the pot holes down S. Hackberry St need help ASAP
Through traffic needs to be a primary focus. Local citizens have learned to navigate around the main streets, but there is no relief in downtown with traffic that is just trying to get through. Not much traffic is coming through to visit luling, but just to get around it. For those few that are trying to visit, our main street's congestion issues are overwhelming. Priority should be an alternate route for through traffic and adjustment of the intersection lights at the main intersection and flow of traffic.
Just highway traffic
Not that I can think of at this time
There is a serious lack of sidewalks in the town. This is not safe for children and it does not promote fitness and healthy which is imperative for the well being of residents.
1) There is a need for sidewalks and crosswalks for children headed to and from school. 2) There is a need for a truck route or enforcement of an existing truck route for the main intersection at hwy 183 and hwy 90 & hwy 80 - and then at red light heading to San Marcos
The train crossing create some problems
Back roads/potholes
Luling has no traffic problems, low taxes, and friendly people
I am concerned about the amount of trucks and trailers that travel hwy 80 and then turn south onto Hackberry or Magnolia to traverse through downtown Luling. The truck traffic seems to have increased in recent years. Also, these heavy trucks are damaging to the roads in our city. It would be great to have these trucks diverted to a route that bypasses our downtown area. This should relieve the congestion brought about by the trucks and pass-through traffic on weekends and holidays.
I would hate to see a loop around town as it would destroy the town we moved to 10 years ago!
We moved to Luling after many trips from Houston to Kyle and liked the small-town atmosphere. A loop around the town would harm Luling. All you have to do is look around at other small towns that have died once a loop was added.
No loops
No loop around town. It will kill us

The semi traffic through town is a huge problem. But I don't know of any good answer because Luling was built with zero growth in mind.
You will kill our town with a bypass. Look at any other small town that has implemented a bypass and it results in a loss of business.
Don't build by-pass Cross walk on Davis street across hwy 183/80
More signs for I-10 Coming to Luling from East trucks should use hwy 80 to go north
1230 River Park Road is a dirt road to my home. My neighbor and I always have to get our tires changed out. Would like to get it paved.
Better streets in Luling
Different routes for oversized loads and 18 wheelers
Roads are terrible in town and around town. The amount of truck traffic is concerning. Rail road crossings are constantly having maintenance issues
Upgrading street pavement. No other suggestions
Alternate route for oversized loads to travel on
Too many semi trucks running lights write some citations
Gravel trucks coming from San Marcos, through downtown are a hazard and general nuisance.
A bypass will not be beneficial for the town of Luling. Travelers through our town often stop in the stores. Our businesses need the income, and tax revenue benefits our town.
The place is old and needs an upgrade
Keep the traffic better than Austin, tx
Please install red lights at major busy intersections instead of way stops & stop lights
We need a bridge over the railroad tracks near the main 4-way stop. People are trapped when the train breaks down or just decides to stop in town. Can't get to schools or hospitals for anyone. Not the tracks. Heavy traffic on weekends and routed for I-10. Heavy equipment constantly driving through.
- Work on some type of second rail road system bridge) - Also all the large heavy equipment coming through town
Educate the town of the consequence of making right handed turns while an 18-wheeler is also trying to turn the same direction
Address trains and truck traffic
Move the 18 Wheeler's out of town
it's not the big city traffic jam, wait a few minutes and it clears up. If it is major I 10 wreck and traffic is diverted then its a problem but just for a day.
-Get them to use the existing truck route on Huckleberry; upgrade Huckleberry -Safety concerns for intersection of 80/183
Construct at least one underpass or overpass route with rail line for emergency services to utilize during train stoppages.
An overpass over the railroad track
If a bypass highway is constructed Luling will become a ghost town
Traffic on weekend is very heavy and when accidents on 10 and routed through Luling is a nightmare. We catch San Marcos to Port Aransas on Spring Break another nightmare. Along with Austin to the coast. One other problem is the stop sign on Milian St. to hospital. Should not have to stop at that extra stop sign when your in emergency.
The trains are horrible and traffic out by the Bucces light backs up bad in the summer
We don't need a. Bypass. We need all the business we can get. Luling people don't support businesses here
A loop to bypass Luling should not be an option. Stream line the truck traffic on Pierce St to the west end of town then to Hwy 80. Create a overpass over the railroad on the west end of

town. Separate the kids walking path north of the railroad from the hazardous truck route. I definitely want to be involved in any future discussions and planning to provide input. I have seen what Interstates 10 did to almost destroy the local economy, I don't want to see it happen again.

More traffic lights on Austin and 80

looking forward to a by-pass around town to help with congestion.

I would like to see crosswalks/crossing guards for the local school children. Some, if not most have to cross at least one-three major highways to get to school. We need to focus on the safety of our children in our community.

Connect Highway 80 with US 90 west of Luling

Improve walking traffic areas for safety. Main St & 183 Hwy there is no crosswalk or light. Hackberry & 90 Hwy A light for schoolchildren and crosswalk recommended. Study routes where seniors, handicap and children travel. Keep there stakeholder in-mind as you plan for change.

Train & trucking traffic creates safety concerns & traffic congestion. Can we consider a no noise ordinance for the train traffic and a reduction of the number of trains, and a possible bypass for truck traffic.

It's just very congested w/ all the 18 wheelers coming through from Hwy 80 to I-10

Consider what will happen with closing Oak Street railroad crossing. During Thump traffic is directed along Oak to 183 so people are familiar with the route.

Fix rough streets, such as Hackberry More police presence to decrease speeding vehicles!

Loss of traffic will KILL DOWNTOWN Without the traffic - our small business will die out - Due to flood zones there isn't any good place to relocate our downtown - & loss of the historic nature of our downtown would destroy attraction of tourists too! I suggest enforcing the existing truck route!

Hazmat on train 4 truck pedestrian, access from schools to 'north side' condition of R/R signals. Conditions of roads. Increased traffic due to 130. Funds being diverted to Lockhart. Overpass over railroad. I am concerned that we look at the overall needs of the area and not look at keeping city merchants busy.

Nothing, other than the fact that it gets crazy congested on Friday

What We Heard

Survey Response Summary - Spanish

Favor de compartir sus opiniones sobre el transporte en Luling. Indique su nivel de interés con:

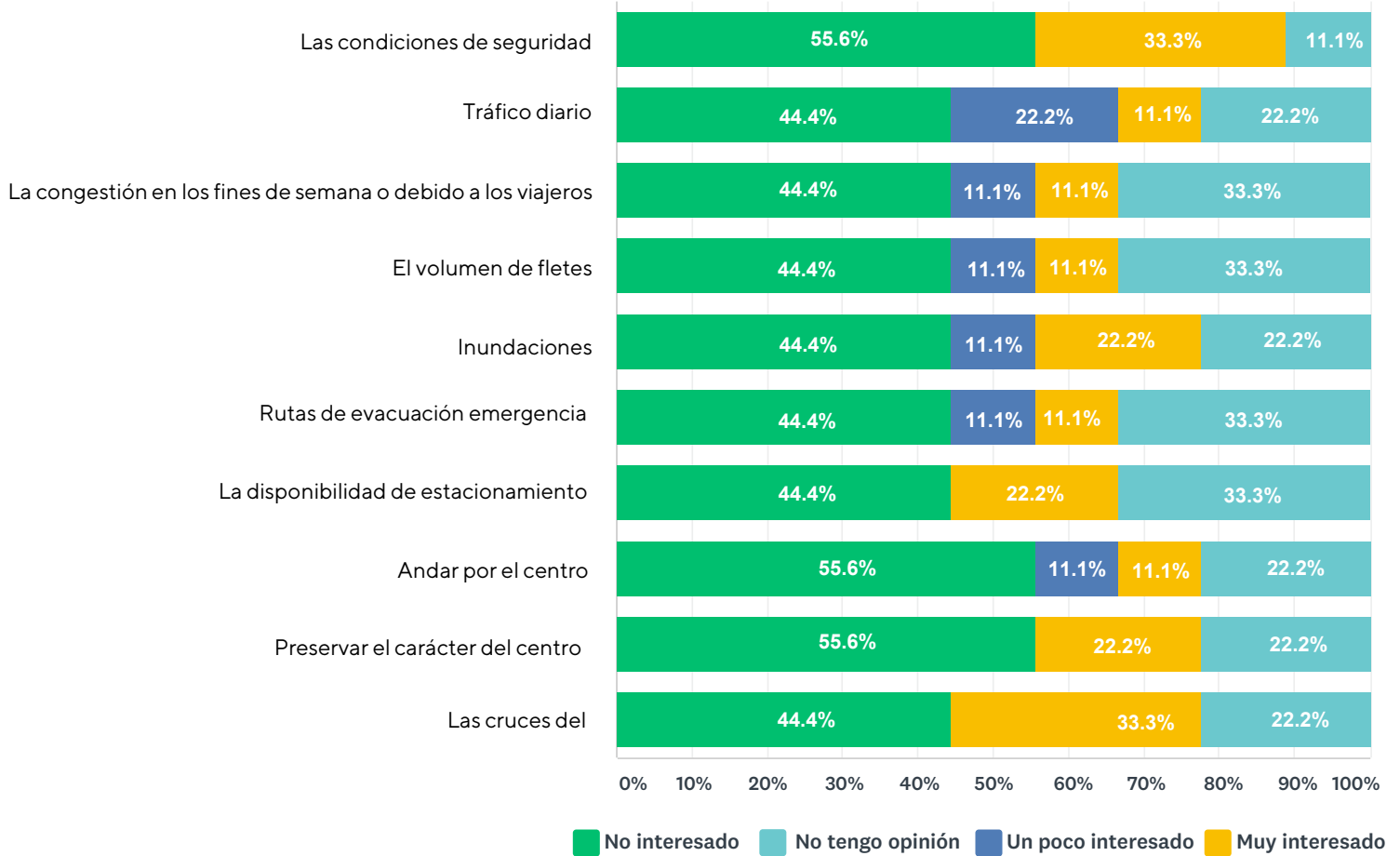

¿Qué le trae a Luling? (seleccione todas las que apliquen)

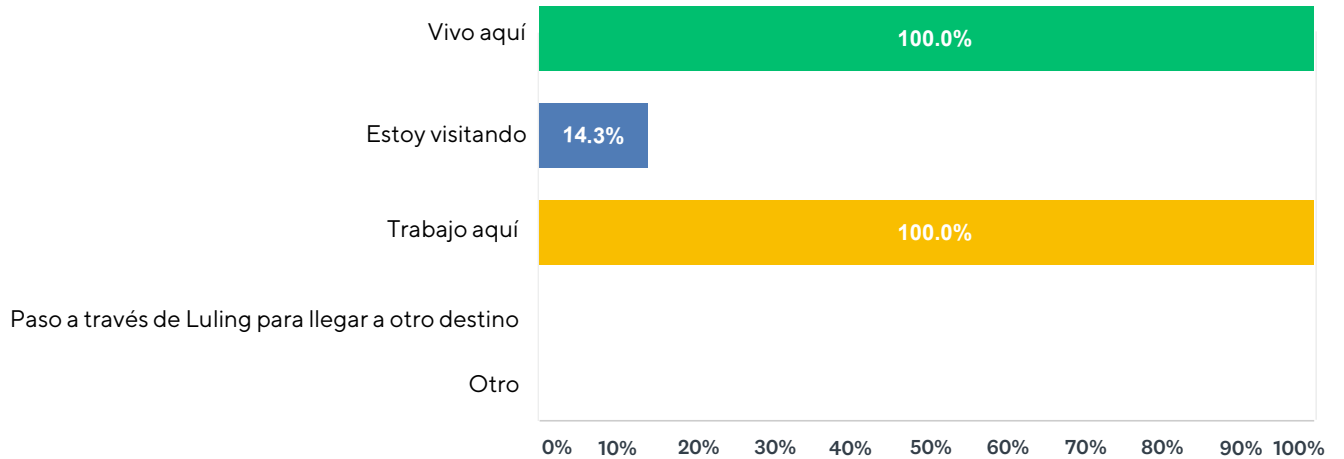

¿Qué le trae a Luling? (detalles adicionales)

No additional details

¿Está Usted de acuerdo con las metas del estudio?

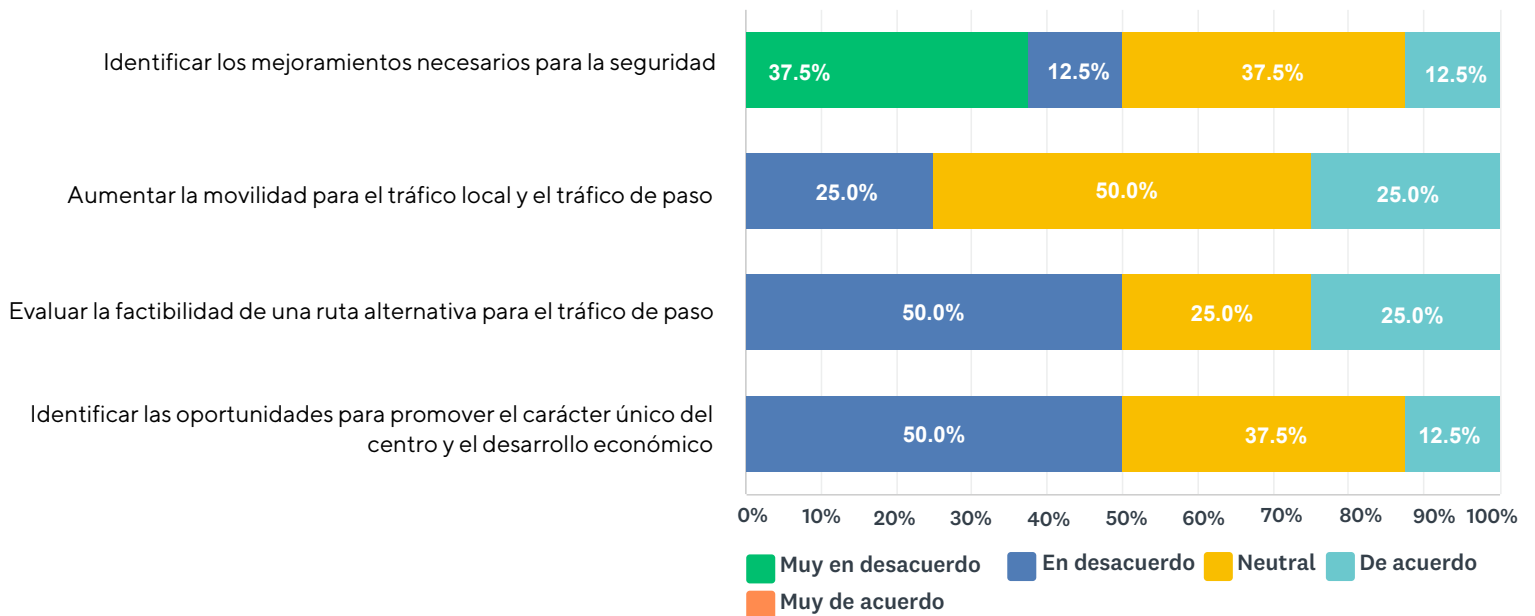

¿Tiene algunos comentarios adicionales sobre el transporte en Luling?

No additional comments

- 9. Discussion/Action** regarding the burn ban.
Cost: None; Speaker: Judge Haden / Carine Chalfoun; Backup: None.

10. Discussion/Action to issue an order allowing retail fireworks permit holders to sell fireworks to the public in celebration of Memorial Day pursuant to Occupations Code Section 2154.202(h)(1). Cost: None; Speaker: Judge Haden/Carine Chalfoun; Backup: 2

Caldwell County Agenda Item Request Form

To: All Elected Officials and Department Heads – Hand deliver or scan & email to hopy.haden@co.caldwell.tx.us and ezzy.chan@co.caldwell.tx.us . Deadline is 5:00 pm Tuesday before the Regular meetings, however, please submit this completed form ASAP. "Anything missing will cause the Agenda Item to be held over to the next Regular meeting," according to our Rules & Procedures.

AGENDA DATE: 5/13/2019

Type of Agenda Item

- Consent Discussion/Action Executive Session Workshop
 Public Hearing

What will be discussed? What is the proposed motion?

to issue an order allowing retail fireworks permit holders to sell fireworks to the public in celebration of Memorial Day pursuant to Occupations Code Section 2154.202(h)(1)

1. **Costs:**

Actual Cost or Estimated Cost \$ None

Is this cost included in the County Budget? _____

Is a Budget Amendment being proposed? _____

2. **Agenda Speakers:**

	Name	Representing	Title
--	------	--------------	-------

(1) Judge Haden

(2) Carine Chalfoun

(3) _____

3. **Backup Materials:** None To Be Distributed 2 total # of backup pages
(including this page)

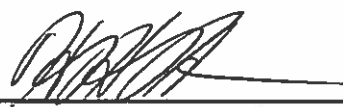
4. 
Signature of Court Member _____

Date 5/9/19

STATE OF TEXAS §
COUNTY OF CALDWELL §

ORDER AUTHORIZING MEMORIAL DAY FIREWORKS SALES

WHEREAS, the Commissioners Court of Caldwell County is authorized under Occupations Code Section 2154.202(h)(1) to issue an Order allowing retail fireworks permit holders to sell fireworks to the public in celebration of Memorial Day; and

WHEREAS, on the 13th of May, 2019, the Commissioners Court of Caldwell County has determined that conditions are favorable to issue such an Order;

WHEREAS, this Order expires on midnight, May 27, 2019, once the Memorial Day fireworks season has concluded.

THEREFORE, NOW IT BE RESOLVED, the Commissioners Court of Caldwell County adopts this Order authorizing the sale of fireworks to the public by retail fireworks permit holders during the Memorial Day period beginning May 23, 2019 and ending at midnight May, 27, 2019.

APPROVED this 13th day of May, 2019, by the Caldwell County Commissioners Court.

Attest:

Hoppy Haden
Caldwell County Judge

Teresa Rodriguez
Caldwell County Clerk

11. Discussion/Action to reschedule the May 27, 2019 regularly scheduled Commissioners Court Meeting. **Cost: None; Speaker: Judge Haden; Backup: 1**

Caldwell County Agenda Item Request Form

To: All Elected Officials and Department Heads – Hand deliver or scan & email to hoppy.haden@co.caldwell.tx.us and ezzy.chan@co.caldwell.tx.us . Deadline is 5:00 pm Tuesday before the Regular meetings, however, please submit this completed form ASAP. "Anything missing will cause the Agenda Item to be held over to the next Regular meeting," according to our Rules & Procedures.

AGENDA DATE: 5/13/2019

Type of Agenda Item

- Consent Discussion/Action Executive Session Workshop
 Public Hearing

What will be discussed? What is the proposed motion?

To reschedule the May 27, 2019 regularly scheduled Commissioners Court.

1. Costs:

Actual Cost or Estimated Cost \$ none

Is this cost included in the County Budget? _____

Is a Budget Amendment being proposed? _____

2. Agenda Speakers:

Name Representing Title

(1) Judge Haden

(2) _____

(3) _____

3. Backup Materials: None To Be Distributed 1 total # of backup pages
(including this page)

4. 
Signature of Court Member

5/7/2019
Date

Exhibit A

12. Discussion/Action to approve Proclamation declaring May 2019 as Elder Abuse Prevention Awareness Month. **Cost: None; Speaker: Judge Haden; Backup: 3**

Caldwell County Agenda Item Request Form

To: All Elected Officials and Department Heads – Hand deliver or scan & email to hoppy.haden@co.caldwell.tx.us and ezzy.chan@co.caldwell.tx.us . Deadline is 5:00 pm Tuesday before the Regular meetings, however, please submit this completed form ASAP. "Anything missing will cause the Agenda Item to be held over to the next Regular meeting," according to our Rules & Procedures.

AGENDA DATE: 5/13/2019

Type of Agenda Item

- Consent
- Discussion/Action
- Executive Session
- Workshop
- Public Hearing

What will be discussed? What is the proposed motion?

to approve Proclamation declaring May 2019 as Elder Abuse Prevention Awareness Month

1. Costs:

Actual Cost or Estimated Cost \$ None

Is this cost included in the County Budget? _____

Is a Budget Amendment being proposed? _____

2. Agenda Speakers:

Name	Representing	Title
(1) <u>Judge Haden</u>		
(2) _____		
(3) _____		

3. Backup Materials: None To Be Distributed 3 total # of backup pages (including this page)

4. [Signature]
Signature of Court Member

5/7/2019
Date



Texas Department of Family and Protective Services

Commissioner
H. L. Whitman, Jr.

LETTER REQUESTING A PROCLAMATION

April 24, 2019

Honorable Judge Hoppy Haden
Caldwell County Commissioner's Court

Dear Judge Haden:

May is **Elder Abuse Prevention Month**. This month provides an excellent opportunity for Caldwell County to demonstrate its support in ending Elder Abuse and to support the numerous victims who are among us. It's a wonderful opportunity to educate the public on the seriousness of abuse, neglect and financial exploitation of the elderly population.

Adult Protective Services and Community Partners would be honored if you would sponsor an official proclamation to recognize May as Caldwell County Elder Abuse Prevention Month. Your proclamation would lend official recognition to the important work of educating the public on Elder Abuse, as well as emphasize your personal commitment to help protect elderly health, safety and rights.

- Statewide APS received 116,578 cases up from the previous year; we completed 84,439 and confirmed 65,955 cases of abuse, neglect or financial exploitation of elderly or adults with a disabling condition in 2018 according to DFPS Annual Data Books.
- **Caldwell County** APS Caseworkers investigated 234 cases and confirmed 149 cases of abuse, neglect and/or financial exploitation in 2018 according to DFPS Annual Data Books.

I have enclosed a sample proclamation, which may help your office compose the appropriate proclamation for Caldwell County. We are requesting to be placed on the Commissioner Court Agenda in May as determined by the court.

Respectfully Submitted,

Samuel Cortina
Community Engagement Specialist
Adult Protective Services

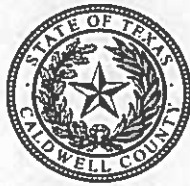

2019 Proclamation Declaring May as Elder Abuse Prevention Awareness Month

WHEREAS, People who are elderly or have disabilities have contributed to the general welfare of **Caldwell County** by helping to preserve customs, convictions, and traditions of many people from diverse backgrounds; and

WHEREAS, these residents are vital and integral members of our society and their wisdom and experience have enriched our lives; and

WHEREAS, Abuse of the elderly and people with disabilities in domestic and institutional settings is a wide-spread problem, affecting hundreds of thousands of people across the country; and

WHEREAS, Texas APS In-Home Caseworkers in **Caldwell County** have investigated 234 intakes of which 149 cases of Abuse, Neglect and/or Exploitation were confirmed against our elderly Texans or those with disabilities in **2018**;

WHEREAS, Elder abuse is grossly underreported because the elderly who are being abused find it very difficult to tell anyone and are usually ashamed and sometimes afraid; and

WHEREAS, Elder abuse happens to men and women of all income levels, all cultural and ethnic groups, whether they are in good health or incapacitated in some way, in poor neighborhoods and in suburbia; and

WHEREAS, many of the cases investigated by Adult Protective Services in Texas involve self-neglect and it is our duty as citizens to reach out to people in need;

NOW, THEREFORE, **Caldwell County Commissioners Court** does hereby proclaim the month of May 2019 to be Elder Abuse Prevention Month in **Caldwell County** and urge all citizens to work together to help reduce abuse and neglect of people who are elderly or have disabilities.

Adopted this 13th of May 2019

Hoppy Haden
County Judge

B. J. Westmoreland
Commissioner, Precinct 1

Barbara Shelton
Commissioner, Precinct 2

Edward "Ed" Theriot
Commissioner, Precinct 3

Joe Ivan Roland
Commissioner, Precinct 4

Attest: _____
Teresa Rodriguez
County Clerk

13. Discussion/Action to approve Proclamation declaring May 19-25, 2019 as EMS Week.
Cost: None; Speaker: Judge Haden; Backup: 2

Caldwell County Agenda Item Request Form

To: All Elected Officials and Department Heads – Hand deliver or scan & email to hoppy.haden@co.caldwell.tx.us and ezzy.chan@co.caldwell.tx.us . Deadline is 5:00 pm Tuesday before the Regular meetings, however, please submit this completed form ASAP. "Anything missing will cause the Agenda Item to be held over to the next Regular meeting," according to our Rules & Procedures.

AGENDA DATE: 5/13/2019

Type of Agenda Item

- Consent
- Discussion/Action
- Executive Session
- Workshop
- Public Hearing

What will be discussed? What is the proposed motion?
to approve EMS Services Week Proclamation

1. Costs:

Actual Cost or Estimated Cost \$ None

Is this cost included in the County Budget? _____

Is a Budget Amendment being proposed? _____

2. Agenda Speakers:

Name	Representing	Title
(1) <u>Judge Haden</u>		
(2) _____		
(3) _____		

3. Backup Materials: None To Be Distributed 2 total # of backup pages (including this page)

4. 
Signature of Court Member

Date 5/7/19



Proclamation
Of The Caldwell County Commissioners Court
“Recognition of Emergency Medical Services (EMS) Week”
May 19-25, 2019

WHEREAS, emergency medical services is a vital public service; and

WHEREAS, every day, citizens rely on emergency medical services (EMS) systems to help them in their hour of greatest need; and

WHEREAS, the emergency service system consists of emergency physicians, emergency nurses, emergency medical technicians (EMTs), paramedics, administrators and others; and

WHEREAS, when accidents and illnesses strike unexpectedly, EMS personnel are first on the scene, and their timely actions often make the difference between life and death; and

WHEREAS, whether by car, ambulance, helicopter, boat or plane, the committed members of our EMS teams are ready to provide lifesaving care to those in need 24 hours a day, seven days a week; and

WHEREAS, access to quality emergency care dramatically improves the survival and recovery rate of those who experience sudden illness or injury; and

WHEREAS, we would like to take the time to recognize the value and contributions of our emergency medical services providers by designation Emergency Medical Services Week.

NOW, THEREFORE, be it resolved, that on this **13th day of May 2019**, the Caldwell County Commissioners Court does hereby proclaim May 19-25, 2019 as

“Emergency Medical Services Week”

Hoppy Haden
County Judge

B. J. Westmoreland
Commissioner, Precinct 1

Barbara Shelton
Commissioner, Precinct 2

Edward “Ed” Theriot
Commissioner, Precinct 3

Joe Ivan Roland
Commissioner, Precinct 4

Attest: _____
Teresa Rodriguez, County Clerk

14. Discussion/Action to approve Resolution 18-2019 to submit a grant to the Texas Judicial Commission on Mental Health. **Cost: None; Speakers: Judge Haden/ Dennis Engelke; Backup: 4**

Caldwell County Agenda Item Request Form

To: All Elected Officials and Department Heads – Hand deliver or scan & email to hoppy.haden@co.caldwell.tx.us and ezzy.chan@co.caldwell.tx.us . Deadline is 5:00 pm Tuesday before the Regular meetings, however, please submit this completed form ASAP. "Anything missing will cause the Agenda Item to be held over to the next Regular meeting," according to our Rules & Procedures.

AGENDA DATE: May 13, 2019

Type of Agenda Item

- Consent Discussion/Action Executive Session Workshop
 Public Hearing

What will be discussed? What is the proposed motion?

Discussion/Action to approve submitting a grant to the Texas Judicial Commission on Mental Health.

1. Costs:

Actual Cost or **Estimated Cost** \$ 0

Is this cost included in the County Budget? _____

Is a Budget Amendment being proposed? _____

2. Agenda Speakers:

	Name	Representing	Title
(1)	Judge Haden	Caldwell County	County Judge
(2)	Dennis Engelke	Caldwell County	Grants Administrator
(3)	_____	_____	_____

3. Backup Materials: None To Be Distributed 34 total # of backup pages
(including this page)

4. 

Signature of Court Member

April 30, 2019

Date



RESOLUTION NO. 18-2019

WHEREAS, the Caldwell County Commissioners Court supports developing criminal justice-mental health partnerships aimed at identifying potential opportunities for diversion, or alternative justice and behavioral health interventions for persons with mental health needs and co-occurring disorders; and

WHEREAS, the Caldwell County Commissioners Court finds it in the best interest of the citizens of Caldwell County, Texas, that a Texas Judicial Commission on Mental Health grant be pursued for purposes of court improvement, capacity building and/or mental health client-service initiatives with the guidance and direction of Bluebonnet Trails Community Services; and

WHEREAS, the Caldwell County Commissioners Court agrees that in the event of loss or misuse of the Texas Judicial Commission on Mental Health funds, the Caldwell County Commissioners Court assures that the funds will be returned to the Texas Judicial Commission on Mental Health in full; and

WHEREAS, the Caldwell County Commissioners Court designates Hoppy Haden, Caldwell County Judge, as the grantee's authorized official. The authorized official is given the power to apply for, accept, reject, alter or terminate the grant on behalf of the applicant agency; and

WHEREAS, the Caldwell County Commissioners Court designates Barbara Gonzales, Caldwell County Auditor, as the grantee's Financial Officer.

NOW THEREFORE, BE IT RESOLVED that the Caldwell County Commissioners Court approves the submission of a grant to the Texas Judicial Commission on Mental Health.

Passed and approved this 13th day of May, 2019.

Hoppy Haden, County Judge

B. J. Westmoreland, Commissioner, Precinct 1

Barbara Shelton, Commissioner, Precinct 2

Edward "Ed" Theriot, Commissioner, Precinct 3

Joe Ivan Roland, Commissioner, Precinct 4

ATTEST:

Teresa Rodriguez, County Clerk

TEXAS JUDICIAL COMMISSION ON MENTAL HEALTH GRANT BACKGROUND INFORMATION

Problem or Issue:

Caldwell County believes there are persons involved in the criminal justice system who do not belong there. A segment of the population frequently re-entering the system on petty offenses may more appropriately receive behavioral health treatment rather than incarceration for the offense. Although public safety is the priority, we recognize a significant number of persons may be diverted or may have reduced sentences if moved into more appropriate treatment environments.

To that end, Caldwell County is seeking to strengthen the relationships among the judicial, law enforcement, jail and local mental health authority system in order to refine the system of care. The vehicle identified for this learning community is the sequential intercept model (SIM) mapping instrument to identify the points within these systems where a person experiencing a psychiatric crisis may enter the system – and how that system may best assist the individual in receiving the right care, in the right setting, at the right time.

Goals of the Project:

Through the SIM mapping instrument, Caldwell County aims to achieve the following goals:

- (1) Develop a comprehensive picture of how people with mental illness and co-occurring disorders flow through the criminal justice system along six distinct intercept points: (0) Mobile Crisis Outreach Teams/Co-Response, (1) Law Enforcement and Emergency Services, (2) Initial Detention and Initial Court Hearings, (3) Jails and Courts, (4) Re-entry, (5) Community Corrections/Community Support.
- (2) Identify challenges, resources, and opportunities at each intercept for individuals in the target population.
- (3) Develop priorities for activities designed to improve the system and service-level responses for individuals in the target population.
- (4) Develop an action plan to implement the priorities.
- (5) Nurture cross-system communication and collaboration.

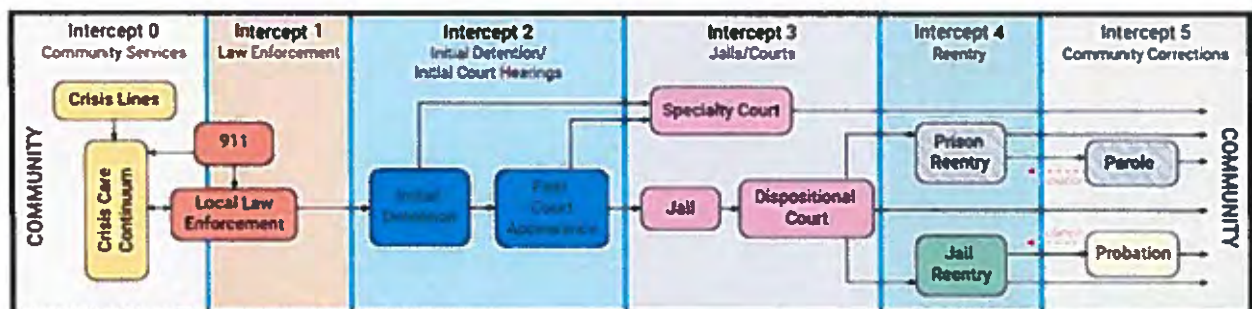

Project Activities:

Through our Local Mental Health Authority (LMHA) partner, Bluebonnet Trails Community Services, Caldwell County will engage certified SIM facilitators to conduct a mapping of the Caldwell County intercepts into the local justice system. The SIM, developed by Mark R. Munetz, M.D. and Patricia A. Griffin, Ph.D. in conjunction with the Substance Abuse and Mental Health Services Administration's (SAMHSA) GAINS Center, Munetz, M., & Griffin, P. (2006). The SIM systemic approach to the de-criminalization of people with serious mental illness has been used as a focal point for states and communities to assess available resources, determine gaps in services, and plan for community change. These activities are best accomplished by a team of stakeholders that cross over multiple systems, including mental health, substance abuse, law enforcement, pretrial services, courts, jails, community corrections, housing, health, social services, peers, family members and many others.

A Sequential Intercept Model-mapping workshop will be conducted to develop a map illustrating how people with behavioral health needs come in contact with and flow through the criminal justice system. Through the workshop, facilitators and participants identify opportunities for linkage to services and for preservation of further penetration into the criminal justice system. This workshop will take place by August 31, 2019 and will result in a report with recommendations for strengthening the intercepts for persons with behavioral health needs as they continue their recovery in our communities.

Following the mapping, a report with recommendations, critical action steps and timeline will be developed with the certified facilitator. Caldwell County will follow up with a prioritized action plan guiding the jail-based and court-based services. Senate Bill 292 funding received by Bluebonnet Trails Community Services supports justice-related services in Caldwell County.

15. Discussion/Action to approve Resolution 19-2019, supporting the construction of FM 110 from State Highway 123 to I-35 at Yarrington Road. **Cost: None; Speaker: Commissioner Theriot; Backup: 3**

Caldwell County Agenda Item Request Form

To: All Elected Officials and Department Heads – Hand deliver or scan & email to hoppy.haden@co.caldwell.tx.us and ezzy.chan@co.caldwell.tx.us . Deadline is 5:00 pm Tuesday before the Regular meetings, however, please submit this completed form ASAP. "Anything missing will cause the Agenda Item to be held over to the next Regular meeting," according to our Rules & Procedures.

AGENDA DATE: 5/13/2019

Type of Agenda Item

- Consent
- Discussion/Action
- Executive Session
- Workshop
- Public Hearing

What will be discussed? What is the proposed motion?

To approve Resolution 19-2019 supporting the construction of FM 110 from State Highway 123 to I-35 at Yarrington Road.

1. Costs:

Actual Cost or Estimated Cost \$ none

Is this cost included in the County Budget? _____

Is a Budget Amendment being proposed? _____

2. Agenda Speakers:

Name	Representing	Title
(1) <u>Commissioner Theriot</u>		
(2) _____		
(3) _____		

3. Backup Materials: None To Be Distributed 3 total # of backup pages (including this page)

4. 
Signature of Court Member

5/7/2019
Date



Resolution 19-2019

A RESOLUTION OF THE COMMISSIONERS COURT OF CALDWELL, TEXAS SUPPORTING THE CONSTRUCTION OF FM 110 FROM STATE HIGHWAY 123 TO I-35 AT YARRINGTON ROAD.

WHEREAS, FM 110 is included in the approved Hays County Transportation Plan, San Marcos Transportation Plan, Capital Area Metropolitan Planning Organization Regional Transportation and was ranked the 13th highest priority new location project in Caldwell County's currently adopted Transportation Plan; and

WHEREAS, Caldwell County has contributed \$1.0 million of the County's allocated Surface Transportation Program Metropolitan Mobility funding toward the FM 110 project; and

WHEREAS, FM 110 will address safety and mobility needs and support economic development in the region; and

WHEREAS, Hays County, in partnership with the Texas Department of Transportation, is nearing completion of project development, including construction design, environmental re-evaluation, right-of-way acquisition and utility relocation for the three (3) segments of FM 110, namely FM 110 from SH 123 to FM 621 ("Southern section"); FM 110 from FM 621 to SH 80 ("Middle section"), and FM 110 from SH 80 to I-35 at Yarrington Road ("Northern section");

NOW, THEREFORE, BE IT RESOLVED:

Section 1. That the Commissioners Court of Caldwell County does support the construction of FM 110 from State Highway 123 to I-35 at Yarrington Road.

Passed and approved this ____ day of _____, 2019.

Hoppy Haden
County Judge

B. J. Westmoreland
Commissioner, Precinct 1

Barbara Shelton,
Commissioner, Precinct 2

Edward "Ed" Theriot
Commissioner, Precinct 3

Joe Ivan Roland
Commissioner, Precinct 4

ATTEST:

Teresa Rodriguez
County Clerk



A Resolution of the Hays County Commissioners Court Supporting
the Construction of FM 110 from State Highway 123 to I-35 at Yarrington Road

STATE OF TEXAS §
 §
COUNTY OF HAYS §

WHEREAS, FM 110 is included in the approved Hays County Transportation Plan, San Marcos Transportation Plan, and Capital Area Metropolitan Planning Organization Regional Transportation Plan; and

WHEREAS, FM 110 will address safety and mobility needs and support economic development in the County and the City; and

WHEREAS, Hays County, in partnership with the Texas Department of Transportation, is nearing completion of project development, including construction design, environmental re-evaluation, right-of-way acquisition and utility relocation for the three (3) segments of FM 110, namely FM 110 from SH 123 to FM 621 ("FM South"); FM 110 from FM 621 to SH 80 ("FM 110 Middle"), and FM 110 from SH 80 to I-35 at Yarrington Road ("FM 110 North");

NOW, THEREFORE, BE IT RESOLVED by the Hays County Commissioners Court:

- (a) That the Commissioners Court of Hays County does support the construction of FM 110 from State Highway 123 to I-35 at Yarrington Road.

RESOLVED, ORDERED, AND DECLARED this 2nd day of April, 2019.



Ruben Becerra
Hays County Judge



Debbie Gonzales Ingalsbe
Commissioner, Pct. 1

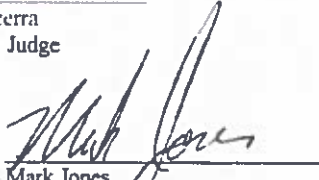

Mark Jones
Commissioner, Pct. 2



Lon Shell
Commissioner, Pct. 3



Walt Smith
Commissioner, Pct. 4

ATTEST:

Elaine H. Cárdenas
Hays County Clerk



16. Discussion/Action to approve a \$900.00 donation request from Caldwell-Travis Soil and Water Conservation District #304. **Cost: \$900.00; Speaker: Judge Haden; Backup: 3**

Caldwell County Agenda Item Request Form

To: All Elected Officials and Department Heads – Hand deliver or scan & email to hoppy.haden@co.caldwell.tx.us and ezzy.chan@co.caldwell.tx.us . Deadline is 5:00 pm Tuesday before the Regular meetings, however, please submit this completed form ASAP. "Anything missing will cause the Agenda Item to be held over to the next Regular meeting," according to our Rules & Procedures.

AGENDA DATE: 5/13/2019

Type of Agenda Item

Consent Discussion/Action Executive Session Workshop
 Public Hearing

What will be discussed? What is the proposed motion?

to approve \$900 donation to Caldwell-Travis Soil and Water Conservation District #304

1. **Costs:**

Actual Cost or Estimated Cost \$ 900.00

Is this cost included in the County Budget? yes

Is a Budget Amendment being proposed? no

2. **Agenda Speakers:**

Name	Representing	Title
------	--------------	-------

(1) Judge Haden

(2) _____

(3) _____

3. **Backup Materials:** None To Be Distributed 3 total # of backup pages
(including this page)

4. 
Signature of Court Member

5/7/2019
Date



Caldwell-Travis Soil and Water Conservation District #304

1403-D Black Jack St. - Lockhart, Texas 78644 - Phone (512) 398-2121

May 3, 2019

Hoppy Haden
Caldwell County Judge
110 South Main
Lockhart, Texas 78644

Dear Haden:

This letter is in regards to the contribution that the County gives to the Caldwell-Travis Soil and Water Conservation District.

We would like to ask for the \$900.00, which you put in your budget for 2020.

The funds are greatly appreciated, and will help us to put conservation to the people in our county.

We want to thank you for your past contributions, and if there is anything we can do for you, please feel free to call us.

Sincerely,

Donald Graham
Chairman

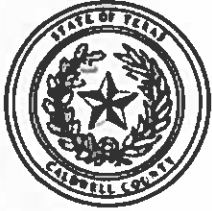

Caldwell County, TX

Detail vs Budget Report

Account Detail

Date Range: 10/01/2018 - 05/06/2019

Account	Name	Fiscal Budget	Beginning Balance	Total Activity	Ending Balance	Budget Remaining	% Remaining
Department : 6510 - NON-DEPARTMENTAL							
Fund: 001 - GENERAL FUND							
Expense							
<u>001-6510-3200</u>	DONATIONS	10,000.00	0.00	50.00	50.00	9,950.00	99.50 %
Post Date	Packet Number	Source Transaction	Pmt Number	Description	Vendor	Project Account	Amount
02/11/2019	APPKT02946	21119	76936	2019 LIONS CLUB FLAG RENTAL PROGRA	LULLIO - LULING LIONS CLUB		50.00
Expense Totals:		10,000.00	0.00	50.00	50.00	9,950.00	99.50 %
001 - GENERAL FUND Totals:		10,000.00	0.00	50.00	50.00	9,950.00	99.50 %
6510 - NON-DEPARTMENTAL Totals:		10,000.00	0.00	50.00	50.00	9,950.00	99.50 %
Report Total:		10,000.00	0.00	50.00	50.00	9,950.00	99.50 %

CARTS-PO (3000)

 \$ 6,950.00

17. Discussion/Action to approve Budget Amendment #22 from Court Admin Assistant (001-6510-1040) to Dues and Subscription (001-6560-3050) **Cost: None; Speaker: Judge Haden; Backup: 3**

Caldwell County Agenda Item Request Form

To: All Elected Officials and Department Heads – Hand deliver or scan & email to hoppy.haden@co.caldwell.tx.us and ezzy.chan@co.caldwell.tx.us . Deadline is 5:00 pm Tuesday before the Regular meetings, however, please submit this completed form ASAP. "Anything missing will cause the Agenda Item to be held over to the next Regular meeting," according to our Rules & Procedures.

AGENDA DATE: 05/13/2019

Type of Agenda Item

- Consent Discussion/Action Executive Session Workshop
 Public Hearing

What will be discussed? What is the proposed motion?

to approve budget amendment # 22 from Court Admin Assistant (001-6560-1040) to Dues and Subscription (001-6560-3050)

1. Costs:

Actual Cost or Estimated Cost \$ 2000

Is this cost included in the County Budget? no

Is a Budget Amendment being proposed? yes

2. Agenda Speakers:

	Name	Representing	Title
--	------	--------------	-------

(1) Judge Haden

(2) _____

(3) _____

3. Backup Materials: None To Be Distributed 3 total # of backup pages
(including this page)

4. 
Signature of Court Member

5/7/2019
Date



Caldwell County, TX

Detail vs Budget Report Account Detail

Date Range: 10/01/2018 - 04/15/2019

Account	Name	Fiscal Budget	Beginning Balance	Total Activity	Ending Balance	Budget Remaining	% Remaining
Department : 6560 - COMMISSIONERS COURT Fund: 001 - GENERAL FUND Expense							
<u>001-6560-1115</u>	Phone Stipend	5,520.00	0.00	2,906.10	2,906.10	2,613.90	47.35 %
Post Date	Packet Number	Source Transaction	Pmt Number	Description	Vendor	Project Account	Amount
10/19/2018	PYPKT01091	PYPKT01091 - 10192018		PYPKT01091 - 10192018 payroll - Pay 10/			230.00
11/02/2018	PYPKT01103	PYPKT01103 - 11022018		PYPKT01103 - 11022018 payroll - Pay 11/			212.32
11/16/2018	PYPKT01121	PYPKT01121 - 11162018		PYPKT01121 - 11162018 payroll - Pay 11/			212.32
11/30/2018	PYPKT01126	PYPKT01126 - 11302018		PYPKT01126 - 11302018 payroll - Pay 11/			246.94
12/14/2018	PYPKT01138	PYPKT01138 - 12142018		PYPKT01138 - 12142018 payroll - Pay 12/			212.32
12/28/2018	PYPKT01144	PYPKT01144 - 12282018		PYPKT01144 - 12282018 payroll - Pay 12/			212.32
01/11/2019	PYPKT01158	PYPKT01158 - 122318 T		PYPKT01158 - 122318 Thru 010519 Pay P			304.82
01/25/2019	PYPKT01197	PYPKT01197 - 010619 th		PYPKT01197 - 010619 thru 011919 Payrol			212.51
02/08/2019	PYPKT01212	PYPKT01212 - 012019 th		PYPKT01212 - 012019 thru 020219 Payrol			212.51
02/22/2019	PYPKT01240	PYPKT01240 - 020319 to		PYPKT01240 - 020319 to 021619 pay peri			212.51
03/08/2019	PYPKT01263	PYPKT01263 - 021719 th		PYPKT01263 - 021719 thru 030219 Pay Pe			212.51
03/22/2019	PYPKT01272	PYPKT01272 - 030319 th		PYPKT01272 - 030319 thru 031619 Payrol			212.51
04/05/2019	PYPKT01278	PYPKT01278 - 031719 th		PYPKT01278 - 031719 thru 033019 Pay Pe			212.51
<u>001-6560-3050</u>	<u>DUES & SUBSCRIPTIONS</u>	3,500.00	0.00	4,655.00	4,655.00	-1,155.00	-33.00 %
Post Date	Packet Number	Source Transaction	Pmt Number	Description	Vendor	Project Account	Amount
10/16/2018	GLPKT14774	JN11650		RECLASS TRAINING ITEMS CHK 76019			200.00
10/31/2018	APPKT02809	1623451-20181031	76113	BILLING ID: 1623451 OCT 2018	LEXRIS - LEXISNEXIS RISK DATA MANAGEMENT		50.00
11/30/2018	APPKT02859	1623451-20181130	76404	BILLING ID: 1623451 NOVEMBER 2018	LEXRIS - LEXISNEXIS RISK DATA MANAGEMENT		50.00
12/31/2018	APPKT02877	1623451-20181231	76554	BILLING ID: 1623451 DECEMBER 2018 MI	LEXRIS - LEXISNEXIS RISK DATA MANAGEMENT		50.00
01/01/2019	APPKT02922	244059/280	76859	ANNUAL DUES FOR HOPPY HAYDEN 1/01/	TACDUE - TEXAS ASSOCIATION OF COUNTIES		1,225.00
01/17/2019	APPKT02922	CAMPO-17-059 2019	76776	LOCAL CONTRIBUTION FOR 2019	CAMPO - CAPITAL AREA METROPOLITAN PLANNING ORG.		1,130.00
01/28/2019	APPKT02971	2019	77046	2019 DUES FOR HOPPY HADEN	COUJUD - COUNTY JUDGES & COMMISSION ASSOC/TEXAS		1,500.00
01/31/2019	APPKT02946	1623451-20190131	76931	BILLING ID: 1623451 JANUARY 2019 MIN	LEXRIS - LEXISNEXIS RISK DATA MANAGEMENT		50.00
02/06/2019	GLPKT14775	JN11651		RECLASS TRAINING ITEMS CHK 76958			300.00
02/28/2019	APPKT02994	1623451-20190228	77240	BILLING ID: 1623451 FEBRUARY, 2019	LEXRIS - LEXISNEXIS RISK DATA MANAGEMENT		50.00
03/31/2019	APPKT03032	1623451-2090331		BILLING ID: 1623451 BILLING PERIOD: M	LEXRIS - LEXISNEXIS RISK DATA MANAGEMENT		50.00
<u>001-6560-3110</u>	OFFICE SUPPLIES	2,000.00	0.00	1,782.53	1,782.53	217.47	10.87 %
Post Date	Packet Number	Source Transaction	Pmt Number	Description	Vendor	Project Account	Amount
10/29/2018	APPKT02765	553030-0	75946	CUST # 12430 SPOTPAPER - LETTER CT	DEWPOT - DEWITT POTHS & SON		98.65

18. Discussion/Action to approve Budget Amendment #23 for money given by Texas State Safety Center. Will be added to Budget for operations. **Cost: none; Speaker: Judge Haden/Steve Kenney/ Constable Bell; Backup: 2**

Caldwell County Agenda Item Request Form

To: All Elected Officials and Department Heads – Hand deliver or scan & email to hoppy.haden@co.caldwell.tx.us and ezzy.chan@co.caldwell.tx.us. Deadline is 5:00 pm Tuesday before the Regular meetings, however, please submit this completed form ASAP. "Anything missing will cause the Agenda Item to be held over to the next Regular meeting," according to our Rules & Procedures.

AGENDA DATE: 5/13/19

Type of Agenda Item

- Consent Discussion/Action Executive Session Workshop
 Public Hearing

What will be discussed? What is the proposed motion?

TO Approve Budget money given by Texas state
Salty Center. To Be Added to Budget for operations

1. Costs:

Actual Cost or Estimated Cost \$ 9400.00

Is this cost included in the County Budget? _____

Is a Budget Amendment being proposed? yes.

2. Agenda Speakers:

	Name	Representing	Title
(1)	<u>Steve Kenney.</u>		<u>Chief Deputy.</u>
(2)	<u>Michael Bell</u>		
(3)			

3. Backup Materials: None To Be Distributed 2 total # of backup pages
(including this page)

4. [Signature]
Signature of Court Member

4/24/19
Date

19. Discussion/Action to approve Budget Amendment #24 to move money from 010-3000-0499 CC-HMAP-J20 revenue line item to 010-6650-4110 Professional Services expense line item. **Cost: None; Speakers: Judge Haden/Dennis Engelke; Backup: 3**

Caldwell County Agenda Item Request Form

To: All Elected Officials and Department Heads – Hand deliver or scan & email to hoppy.haden@co.caldwell.tx.us and ezzy.chan@co.caldwell.tx.us . Deadline is 5:00 pm Tuesday before the Regular meetings, however, please submit this completed form ASAP. "Anything missing will cause the Agenda Item to be held over to the next Regular meeting," according to our Rules & Procedures.

AGENDA DATE: 5/13/19

Type of Agenda Item

- Consent Discussion/Action Executive Session Workshop
 Public Hearing

What will be discussed? What is the proposed motion?

To approve Budget Amendment #24 to move money from 010-3000-0499 CC- HMAP- H2O Revenue to 010-6050-4110 Professional Services Expense line item

1. Costs:

Actual Cost or Estimated Cost \$ 0

Is this cost included in the County Budget? _____

Is a Budget Amendment being proposed? _____

2. Agenda Speakers:

	Name	Representing	Title
<hr/>			

(1) Dennis Engelke

(2) Judge Haden

(3) _____

3. Backup Materials: None To Be Distributed 3 total # of backup pages
(including this page)

4. 
Signature of Court Member

5/7/2019
Date

H₂O PARTNERS

Invoice Date 3/13/2019
 Invoice # 113324
 Terms Net 45

H2O Partners, Inc.
 P.O. Box 160130
 Austin, TX 78716
 Attn: Accounts Receivable
mtrent@h2opartnersusa.com
mhverta@h2opartnersusa.com

Caldwell County
 Carine Chalfoun
 110 S. Main Street, Room 201
 Lockhart, TX 78644
carine.chalfoun@co.caldwell.tx.us
 (512) 398-1822
 Dennis Engelke
dennis.engelke@co.caldwell.tx.us
 (512) 359-4686
kari.labit@co.caldwell.tx.us
 512-398-1801

Hazard Mitigation Action Plan (HMAP) Services Rendered 8/1/18 - 2/28/19

Line Item	Award	Retainage	Billed to Date	Amount Due
Assist with setting up Planning Team; Coordinate, schedule, and host Kickoff Workshop and public meeting; Prepare documents and hazard list for Kickoff Workshop; Conduct preliminary hazard research; Conduct correspondence; Develop capability assessment, hazard ranking sheet, critical facility spreadsheet; Develop public survey	\$ 105,000.00	\$ 10,500.00	\$ -	\$ 9,450.00
Total	\$105,000.00	\$10,500.00	\$0.00	\$9,450.00

STATEMENT OF ACCOUNT

Previously Invoiced	Current Invoice	JTD Invoiced
\$ -	\$ 9,450.00	\$ 9,450.00

Date	Invoice #	Amount	Payment	Balance Due
3/13/2019	113324	\$ 9,450.00	\$ -	\$ 9,450.00
		\$ 9,450.00		\$ 9,450.00

010-6650-4110

Dennis Engelke

3/14/19

20. Discussion/Action to approve Budget Amendment #25 to move remaining money from 001-2140-1040 to 3 Deputy Clerks, 001-2140-1040, netting zero cost to County. **Cost: None; Speakers: Darla Law/ Judge Haden; Backup: 2**

Caldwell County Agenda Item Request Form

To: All Elected Officials and Department Heads – Hand deliver or scan & email to hoppy.haden@co.caldwell.tx.us and ezzy.chan@co.caldwell.tx.us . Deadline is 5:00 pm Tuesday before the Regular meetings, however, please submit this completed form ASAP. "Anything missing will cause the Agenda Item to be held over to the next Regular meeting," according to our Rules & Procedures.

AGENDA DATE: 5/13/2019

Type of Agenda Item

- Consent Discussion/Action Executive Session Workshop
 Public Hearing

What will be discussed? What is the proposed motion?

to approve Budget Amendment #25 to move remaining money from 001-2140-1040 to 3 Deputy Clerks, 001-2140-1040, netting a zero cost to County.

1. **Costs:**

Actual Cost or Estimated Cost \$ zero

Is this cost included in the County Budget? _____

Is a Budget Amendment being proposed? _____

2. **Agenda Speakers:**

	Name	Representing	Title
--	------	--------------	-------

(1) Judge Haden

(2) Darla Law

(3) _____

3. **Backup Materials:** None To Be Distributed 2 total # of backup pages
(including this page)

4. 
Signature of Court Member

Date 5/7/2019

21. Discussion/Action to approve Budget Amendment #26 to move money from Constable, Pct. 2, office supplies 001-432-3110 to Machinery and equipment, 001-4322-5310 to cover expenses for radar certifications. **Cost: None; Speaker: Judge Haden/ Tom Will; Backup: 3**

Caldwell County Agenda Item Request Form

To: All Elected Officials and Department Heads – Hand deliver or scan & email to hoppy.haden@co.caldwell.tx.us and ezzy.chan@co.caldwell.tx.us . Deadline is 5:00 pm Tuesday before the Regular meetings, however, please submit this completed form ASAP. "Anything missing will cause the Agenda Item to be held over to the next Regular meeting," according to our Rules & Procedures.

AGENDA DATE: 5/13/2019

Type of Agenda Item

- Consent
- Discussion/Action
- Executive Session
- Workshop
- Public Hearing

What will be discussed? What is the proposed motion?

to approve Budget Amendment #26 to move money from Constable 2, office supplies 001-4322-3110 to Machinery and equipment, 001-4322-5310 to cover expenses for radar certifications.

1. Costs:

Actual Cost or Estimated Cost \$ zero

Is this cost included in the County Budget? _____

Is a Budget Amendment being proposed? _____

2. Agenda Speakers:

Name	Representing	Title
------	--------------	-------

(1) Judge Haden

(2) Tom Will

(3) _____

3. Backup Materials:

None To Be Distributed 3 total # of backup pages (including this page)

4. 
Signature of Court Member

Date 5/7/2019

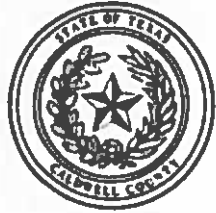

Caldwell County, TX

Detail vs Budget Report Account Summary

Date Range: 10/01/2018 - 03/31/2019

Account	Name	Encumbrances	Fiscal Budget	Beginning Balance	Total Activity	Ending Balance	Budget Remaining	% Remaining
001 - GENERAL FUND								
Expense								
001-4322-1010	ELECTED OFFICIAL	0.00	25,921.00	0.00	11,963.76	11,963.76	13,957.24	53.85 %
001-4322-1036	Deputy Constable (employee)	0.00	20,000.00	0.00	11,014.18	11,014.18	8,985.82	44.93 %
001-4322-1105	Payroll Account Adjustment	0.00	500.00	0.00	500.00	500.00	0.00	0.00 %
001-4322-1115	Phone Stipend	0.00	420.00	0.00	195.15	195.15	224.85	53.54 %
001-4322-2010	SOCIAL SECURITY & MEDICARE TAX	0.00	3,583.00	0.00	1,695.61	1,695.61	1,887.39	52.68 %
001-4322-2020	GROUP MEDICAL INSURANCE	0.00	8,254.00	0.00	3,809.52	3,809.52	4,444.48	53.85 %
001-4322-2030	RETIREMENT	0.00	2,080.00	0.00	1,013.99	1,013.99	1,066.01	51.25 %
001-4322-2070	EMPLOYEE BONDING	0.00	100.00	0.00	0.00	0.00	100.00	100.00 %
001-4322-3110	OFFICE SUPPLIES	0.00	2,100.00	0.00	452.38	452.38	1,647.62	78.46 %
001-4322-4260	TRANSPORTATION	0.00	5,000.00	0.00	2,278.17	2,278.17	2,721.83	54.44 %
001-4322-4810	TRAINING	0.00	1,000.00	0.00	552.84	552.84	447.16	44.72 %
001-4322-5310	MACHINERY AND EQUIPMENT	0.00	0.00	0.00	120.00	120.00	-120.00	0.00 %
Expense Totals:		0.00	68,958.00	0.00	33,595.60	33,595.60	35,362.40	51.28 %
001 - GENERAL FUND Totals:		0.00	68,958.00	0.00	33,595.60	33,595.60	35,362.40	51.28 %
Report Total:		0.00	68,958.00	0.00	33,595.60	33,595.60	35,362.40	51.28 %

22. Discussion/Action to approve Job Descriptions for Executive Assistant and Administrative Assistant–County Commissioners. **Cost: None; Speaker: Judge Haden/Bob Bush; Backup: 7**

Caldwell County Agenda Item Request Form

To: All Elected Officials and Department Heads – Hand deliver or scan & email to hoppy.haden@co.caldwell.tx.us and ezzy.chan@co.caldwell.tx.us . Deadline is 5:00 pm Tuesday before the Regular meetings, however, please submit this completed form ASAP. "Anything missing will cause the Agenda Item to be held over to the next Regular meeting," according to our Rules & Procedures.

AGENDA DATE: 5/13/2019

Type of Agenda Item

- Consent Discussion/Action Executive Session Workshop
 Public Hearing

What will be discussed? What is the proposed motion?

to approve Job Descriptions for Executive Assistant and Administrative Assistant

1. **Costs:**

Actual Cost or Estimated Cost \$ None

Is this cost included in the County Budget? _____

Is a Budget Amendment being proposed? _____

2. **Agenda Speakers:**

	Name	Representing	Title
--	------	--------------	-------

(1)	Judge Haden		
-----	-------------	--	--

(2)	Bob Bush		
-----	----------	--	--

(3)			
-----	--	--	--

3. **Backup Materials:** None To Be Distributed _____ total # of backup pages
(including this page)

4. 

Signature of Court Member

Date 5/7/2019



CALDWELL COUNTY

Job Description

Job Title: Executive Assistant
Department: County Judge's Office
Location: Caldwell County

Salary:
FLSA Status: Non-Exempt
Prepared by: Human Resources Dept.

SUMMARY

The Executive Assistant is responsible for providing secretarial, clerical and administrative support in order to ensure that services are provided in an effective and efficient manner. Generally, this position is the first impression of the County for walk-ins and phone calls. Professional attire required.

SUPERVISION RECEIVED

Works under the general supervision of the County Judge.

SUPERVISION EXERCISED

None.

ESSENTIAL DUTIES AND RESPONSIBILITIES

1. Responsible for preparing, posting and obtaining support documents for the Commissioners Court Agenda. Including, but not limited to; recording on-line video/audio of court meetings, proclamations, resolutions, general orders, budget, and various legal documents.
2. General administrative duties for the County Judge and his direct reporting offices (Emergency Management, Veteran's Services and Information Technology).
3. Responsible for the coordination of all indigent burials.
4. Maintain all the administration electronic files.
5. Direct the public to the appropriate staff member (general information & complaints).
6. Has primary responsibility for the County website.
7. Assist in the planning and preparation of meetings, conferences and conference calls for County Judge
8. Assist with county wide special events and functions for County Judge.
9. Maintains electronic calendar for County Judge.
10. Performs other related duties as required and assigned.

Note: The duties listed above are intended only as illustrations of the various types of work that may be performed. The omission of specific statements of duties does not exclude them from the position if the work is similar, related or a logical assignment to the position and is assigned by the director.

KNOWLEDGE AND SKILLS:

Requires effective oral and written communication skills, excellent interpersonal skills, and computer literacy. Maintain high level of confidentiality.

MANDATORY QUALIFICATIONS:**EDUCATION and/or EXPERIENCE**

High School Diploma required. College degree preferred. At least five years of experience in an office setting.

OTHER SKILLS AND ABILITIES

Microsoft office suite (i.e. email, word, excel), and data base programs; prepare clear and concise records, reports, correspondence and other written materials; exercise independent judgment within general policy guidelines; establish and maintain effective working relationships with those contacted in the course of work.

LANGUAGE SKILLS

Read and comprehend simple instructions, short correspondence, and memos; able to write detailed correspondence; effectively present information in one-on-one and small group situations to elected officials, department heads, vendors, and senior managers and supervisors within the County.

MATHEMATICAL SKILLS

Add, subtract, multiply, and divide in all units of measure, using whole numbers, common fractions, and decimals.

REASONING ABILITY

Apply common sense understanding to carry out detailed but uninvolved written or oral instructions; able to deal with problems involving a few concrete variables in complex situations.

PHYSICAL DEMANDS

Physical demands described here are representative of those that must be met by an employee to successfully perform the essential duties of this job. Reasonable accommodations may be made to enable individuals with disabilities to perform the essential functions of this job.

While performing the duties of this job, the employee is regularly required to stand, walk; use hands to finger, handle, or feel; reach with hands and arms. The employee must regularly lift and/or move up to 20 pounds. Specific vision abilities required by this job include close vision, distance vision, color vision, peripheral vision, depth perception, and ability to adjust focus.

WORK ENVIRONMENT

The work environment characteristics described here are representative of those an employee encounters while performing the essential functions of this job. Reasonable accommodations may be made to enable individuals with disabilities to perform the essential functions.

The noise level in the work environment is usually moderate.

SELECTION GUIDELINES

Formal application, rating of education and experience; oral interview and reference check; job related tests might be required.

This job description does not constitute an employment agreement between the employer and employee and is subject to change by the employer as the needs of the employer and requirements of the job change. The employee further understands, and accepts, that this position falls under the provision of an "At Will" employment, and under no circumstances is this a contract for employment.

Acknowledgement of Employee: _____ Date: _____

Signature of Employee: _____ Date: _____

Signature of Supervisor: _____ Date: _____



CALDWELL COUNTY
Job Description

Job Title: Administrative Assistant – County Commissioners
Department: Commissioners Court
Location: Caldwell County
Salary:
FLSA Status: Non-Exempt
Prepared by: Human Resources Dept.

SUMMARY

The Administrative Assistant – County Commissioners is responsible for providing secretarial, clerical and administrative support in order to ensure that services are provided in an effective and efficient manner. Generally, this position is the first impression of the County for walk-ins and phone calls. Professional attire required.

SUPERVISION RECEIVED

Works under the general supervision of the Commissioners Court.

SUPERVISION EXERCISED

None.

ESSENTIAL DUTIES AND RESPONSIBILITIES

Primary

1. Maintain electronic calendar for all Commissioners
2. Ensures that Courtroom is set up for Commissioner Court meetings and other meetings as necessary upon direction of the County Commissioners.
3. Direct the public to the appropriate staff member (general information & complaints).
4. Assists Human Resources, as needed.
5. Prepares correspondence, memorandums, variety of fiscal, statistical and administrative reports.
6. Daily interaction with the public and county employees.
7. Acts as receptionist for courthouse.
8. Assist in the planning and preparation of meetings, conferences, and conference calls for Commissioners
9. Assist with county wide special events and functions for Commissioners
10. Performs other job-related duties as assigned.

Secondary

1. Assist with the preparation, posting and obtaining support documents for the Commissioners Court Agenda. Including, but not limited to; recording on-line

video/audio of court meetings, proclamations, resolutions, general orders, budget, and various legal documents.

2. Posts Commissioners Court and other County Department information on County Website and ensure that website is maintained and current.

Note: The duties listed above are intended only as illustrations of the various types of work that may be performed. The omission of specific statements of duties does not exclude them from the position if the work is similar, related or a logical assignment to the position and is assigned by the County Commissioners and Department Heads.

KNOWLEDGE AND SKILLS:

Requires effective oral and written communication skills, excellent interpersonal skills, and computer literacy. Maintain high level of confidentiality.

MANDATORY QUALIFICATIONS:

EDUCATION and/or EXPERIENCE

High School Diploma is required. College degree preferred. At least five years of experience in a professional office setting.

OTHER SKILLS AND ABILITIES

Microsoft Office suite (i.e. email, word, excel), and data base programs; prepare clear and concise records, reports, correspondence and other written materials; exercise independent judgment within general policy guidelines; establish and maintain effective working relationships with those contacted in the course of work.

LANGUAGE SKILLS

Read and comprehend simple instructions, short correspondence, and memos; able to write detailed correspondence; effectively present information in one-on-one and small group situations to elected officials, department heads, vendors, and senior managers and supervisors within the County.

MATHEMATICAL SKILLS

Add, subtract, multiply, and divide in all units of measure, using whole numbers, common fractions, and decimals.

REASONING ABILITY

Apply common sense understanding to carry out detailed but uninvolved written or oral instructions; able to deal with problems involving a few concrete variables in complex situations.

PHYSICAL DEMANDS

Physical demands described here are representative of those that must be met by an employee to successfully perform the essential duties of this job. Reasonable accommodations may be made to enable individuals with disabilities to perform the essential functions of this job.

While performing the duties of this job, the employee is regularly required to stand, walk; use hands to finger, handle, or feel; reach with hands and arms. The employee must regularly lift and/or move up to 20 pounds. Specific vision abilities required by this job include close vision, distance vision, color vision, peripheral vision, depth perception, and ability to adjust focus.

WORK ENVIRONMENT

The work environment characteristics described here are representative of those an employee encounters while performing the essential functions of this job. Reasonable accommodations may be made to enable individuals with disabilities to perform the essential functions.

The noise level in the work environment is usually moderate.

SELECTION GUIDELINES

Formal application, rating of education and experience; oral interview and reference check; job related tests might be required.

This job description does not constitute an employment agreement between the employer and employee and is subject to change by the employer as the needs of the employer and requirements of the job change. The employee further understands, and accepts, that this position falls under the provision of an "At Will" employment, and under no circumstances is this a contract for employment.

Acknowledgement of Employee: _____ Date: _____

Signature of Employee: _____ Date: _____

Signature of Supervisor: _____ Date: _____

23. Discussion/Action to review and approve the annual financial audit report for the fiscal year ending September 30, 2018. **Cost: None; Speakers: Lewis Crain, CPA/ Barbara Gonzales/ Judge Haden; Backup: 77**

Caldwell County Agenda Item Request Form

To: All Elected Officials and Department Heads – Hand deliver or scan & email to hoppy.haden@co.caldwell.tx.us and ezzy.chan@co.caldwell.tx.us . Deadline is 5:00 pm Tuesday before the Regular meetings, however, please submit this completed form ASAP. "Anything missing will cause the Agenda Item to be held over to the next Regular meeting," according to our Rules & Procedures.

AGENDA DATE: 05 13 2019

Type of Agenda Item

- Consent Discussion/Action Executive Session Workshop
 Public Hearing

What will be discussed? What is the proposed motion?

Discussion / Action to review and approve the annual financial audit report for the fiscal year ending September 30, 2018.

1. Costs:

Actual Cost or Estimated Cost \$ N/A

Is this cost included in the County Budget? _____

Is a Budget Amendment being proposed? _____

2. Agenda Speakers:

	<u>Name</u>	<u>Representing</u>	<u>Title</u>
(1)	Mr. Lewis Crain, CPA	Rutledge, Crain & Company PC	
(2)	Barbara A. Gonzales	County Auditor	County Auditor
(3)	Hoppy Haden	County Judge	County Judge

3. Backup Materials: None To Be Distributed _____ total # of backup pages
(including this page)

4. 

Signature of Court Member

Date 4/29/16

CALDWELL COUNTY, TEXAS

ANNUAL FINANCIAL REPORT

FOR THE YEAR ENDED SEPTEMBER 30, 2018

This page is left blank intentionally.

CALDWELL COUNTY, TEXAS
ANNUAL FINANCIAL REPORT
FOR THE YEAR ENDED SEPTEMBER 30, 2018

TABLE OF CONTENTS

	<u>Page</u>	<u>Exhibit</u>
FINANCIAL SECTION		
Independent Auditors' Report.....	1	
Management's Discussion and Analysis (Required Supplementary Information).....	5	
<u>Basic Financial Statements</u>		
Government-wide Financial Statements:		
Statement of Net Position.....	14	A-1
Statement of Activities.....	15	A-2
Fund Financial Statements:		
Balance Sheet - Governmental Funds.....	16	A-3
Reconciliation of the Governmental Funds		
Balance Sheet to the Statement of Net Position.....	19	A-4
Statement of Revenues, Expenditures, and Changes in		
Fund Balances - Governmental Funds.....	20	A-5
Reconciliation of the Statement of Revenues, Expenditures, and Changes in		
Fund Balances of Governmental Funds to the Statement of Activities.....	23	A-6
Statement of Fiduciary Net Position - Fiduciary Funds.....	24	A-7
Notes to the Financial Statements	25	
<u>Required Supplementary Information</u>		
Budgetary Comparison Schedules:		
General Fund.....	44	B-1
Unit Road Fund.....	45	B-2
Schedule of Changes in the County's Net Pension Liability		
And Related Ratios -Pension Plan	46	B-3
Schedule of County's Contributions - Pension Plan.....	47	B-4
Notes to Required Supplementary Information.....	48	
<u>Combining Statements and Budgetary Comparison Schedules as Supplementary Information:</u>		
Combining Balance Sheet - All Nonmajor Governmental Funds.....	50	C-1
Combining Statement of Revenues, Expenditures and Changes in		
Fund Balances - All Nonmajor Governmental Funds.....	51	C-2
Special Revenue Funds:		
Combining Balance Sheet - Nonmajor Special Revenue Funds.....	52	C-3
Combining Statement of Revenues, Expenditures and Changes		
in Fund Balances - Nonmajor Special Revenue Funds.....	56	C-4

CALDWELL COUNTY, TEXAS
ANNUAL FINANCIAL REPORT
FOR THE YEAR ENDED SEPTEMBER 30, 2018

TABLE OF CONTENTS

	<u>Page</u>	<u>Exhibit</u>
Budgetary Comparison Schedules:		
Grant Fund.....	60	C-5
Justice Court Technology.....	61	C-6
Records Preservation Fund.....	62	C-7
Law Library.....	63	C-8
Hot Check.....	64	C-9
Records Management	65	C-10
Courthouse Security.....	66	C-11
Debt Service Funds:		
Budgetary Comparison Schedule:		
Debt Service Fund.....	67	C-12
Fiduciary Funds:		
Agency Funds:		
Combining Statement of Fiduciary Assets and Liabilities.....	68	C-13

Financial Section

This page is left blank intentionally.

RUTLEDGE CRAIN & COMPANY,PC
CERTIFIED PUBLIC ACCOUNTANTS
2401 Garden Park Court, Suite B
Arlington, Texas 76013

INDEPENDENT AUDITORS' REPORT

To the To the Honorable County Judge and Commissioners Comprising the
Commissioners' Court of Caldwell County, Texas

We have audited the accompanying financial statements of the governmental activities, each major fund, and the aggregate remaining fund information of Caldwell County, Texas, as of and for the year ended September 30, 2018, and the related notes to the financial statements, which collectively comprise the County's basic financial statements as listed in the table of contents.

Management's Responsibility for the Financial Statements

Management is responsible for the preparation and fair presentation of these financial statements in accordance with accounting principles generally accepted in the United States of America; this includes the design, implementation, and maintenance of internal control relevant to the preparation and fair presentation of financial statements that are free from material misstatement, whether due to fraud or error.

Auditors' Responsibility

Our responsibility is to express opinions on these financial statements based on our audit. We conducted our audit in accordance with auditing standards generally accepted in the United States of America. Those standards require that we plan and perform the audit to obtain reasonable assurance about whether the financial statements are free from material misstatement.

An audit involves performing procedures to obtain audit evidence about the amounts and disclosures in the financial statements. The procedures selected depend on the auditors' judgment, including the assessment of the risks of material misstatement of the financial statements, whether due to fraud or error. In making those risk assessments, the auditor considers internal control relevant to the entity's preparation and fair presentation of the financial statements in order to design audit procedures that are appropriate in the circumstances, but not for the purpose of expressing an opinion on the effectiveness of the entity's internal control. Accordingly, we express no such opinion. An audit also includes evaluating the appropriateness of accounting policies used and the reasonableness of significant accounting estimates made by management, as well as evaluating the overall presentation of the financial statements.

We believe that the audit evidence we have obtained is sufficient and appropriate to provide a basis for our audit opinions.

Opinions

In our opinion, the financial statements referred to above present fairly, in all material respects, the respective financial position of the governmental activities, each major fund, and the aggregate remaining fund information of Caldwell County, Texas, as of September 30, 2018, and the respective changes in financial position for the year then ended in accordance with accounting principles generally accepted in the United States of America.

Other Matters

Required Supplementary Information

Accounting principles generally accepted in the United States of America require that the management's discussion and analysis, budgetary comparison information, and pension disclosures, on pages 5-11, 44-45, and 46-47, respectively, be presented to supplement the basic financial statements. Such information, although not a part of the basic financial statements, is required by the Governmental Accounting Standards Board, who considers it to be an essential part of financial reporting for placing the basic financial statements in an appropriate operational, economic, or historical context. We have applied certain limited procedures to the required supplementary

information in accordance with auditing standards generally accepted in the United States of America, which consisted of inquiries of management about the methods of preparing the information and comparing the information for consistency with management's responses to our inquiries, the basic financial statements, and other knowledge we obtained during our audit of the basic financial statements. We do not express an opinion or provide any assurance on the information because the limited procedures do not provide us with sufficient evidence to express an opinion or provide any assurance.

Other Information

Our audit was conducted for the purpose of forming opinions on the financial statements that collectively comprise Caldwell County, Texas' basic financial statements. The combining and individual nonmajor fund financial statements and schedules, are presented for purposes of additional analysis and are not a required part of the basic financial statements.

The combining and individual nonmajor fund financial statements and schedules are the responsibility of management and were derived from and relate directly to the underlying accounting and other records used to prepare the basic financial statements. Such information has been subjected to the auditing procedures applied in the audit of the basic financial statements and certain additional procedures, including comparing and reconciling such information directly to the underlying accounting and other records used to prepare the basic financial statements or to the basic financial statements themselves, and other additional procedures in accordance with auditing standards generally accepted in the United States of America. In our opinion, the combining and individual nonmajor fund financial statements are fairly stated, in all material respects, in relation to the basic financial statements as a whole.

Autledge Crain & Company, PC

April 8, 2019

Management's Discussion and Analysis

This page is left blank intentionally.

CALDWELL COUNTY, TEXAS
MANAGEMENT'S DISCUSSION AND ANALYSIS
September 30, 2018

As management of Caldwell County, we offer readers of the County's financial statements this narrative overview and analysis of the financial activities of the County for the fiscal year ended September 30, 2018. We encourage readers to consider the information presented herein along with the County's financial statements, which follow this section.

Financial Highlights

The net position of the County increased by \$3,450,919 for fiscal year ended September 30, 2018. The assets and deferred resources outflows of the County exceeded its liabilities and deferred resources inflows at the close of the fiscal year ended September 30, 2018 by \$30,341,539 (net position). Of this amount, \$16,692,071 (unrestricted net assets) may be used to meet the government's ongoing obligations to citizens and creditors.

The County's governmental funds reported combined ending fund balances of \$19,129,657, an increase of \$8,990,300 in comparison to the previous year, due to the timing of revenues received versus work performed with the SH130 project, and a bond issue of \$5,955,000. In addition, increased revenues in the general fund, primarily from taxes, in association with decreases in general fund expenditures, primarily from lapses in staffing and the resulting savings in personnel costs, also contributed to the positive change in fund balance.

The unassigned portion of the General Fund, fund balance at the end of the year was \$10,427,625, or 67.80% of total General Fund expenditures for fiscal year 2018.

Overview of the Financial Statements

This discussion and analysis is intended to serve as an introduction to the County's basic financial statements. The County's basic financial statements comprise four components: 1) government-wide financial statements, 2) fund financial statements, 3) fiduciary financial statements, and 4) notes to the financial statements. This report also contains other supplementary information in addition to the basic financial statements themselves.

Government-wide Financial Statements. The government-wide financial statements are designed to provide readers with a broad overview of Caldwell County's finances. This is done in a manner similar to a private-sector business. Two statements, the Statement of Net Position and the Statement of Activities, are utilized to provide this financial overview.

The Statement of Net Position presents information on all of the County's assets and liabilities with the difference between the two reported as net position. Over time, increases or decreases in net position may serve as a useful indicator of whether the financial position of the County is improving or deteriorating.

The Statement of Activities presents information showing how the government's net position changed during the most recent fiscal year. All changes in net position are reported as soon as the underlying event giving rise to the change occurs, regardless of the timing of related cash flows. Thus, revenues and expenses are reported in this statement for some items that will only result in cash flows in future fiscal periods (e.g., uncollected taxes and earned but unused vacation leave).

In addition, the statement of activities highlights government activities supported by taxes and intergovernmental revenues, along with program revenues classified to the corresponding government activity.

Fund Financial Statements. The County, like other state and local governments, utilizes fund accounting to ensure and demonstrate compliance with finance-related legal requirements. A fund is a grouping of related accounts that is used to maintain control over resources that have been segregated for specific activities or objectives. All of the funds of the County can be divided into two categories: governmental funds and fiduciary funds.

CALDWELL COUNTY, TEXAS
MANAGEMENT'S DISCUSSION AND ANALYSIS
September 30, 2018

Governmental Funds. Governmental funds are used to account for essentially the same functions reported as governmental activities in the government-wide financial statements. However, unlike the government-wide financial statements, governmental fund financial statements focus on near-term inflows and outflows of spendable resources as well as on balances of spendable resources available at the end of the fiscal year. Such information may be useful in evaluating a government's near-term financing requirements.

Because the focus of governmental funds is narrower than that of the government-wide financial statements, it is useful to compare the information presented for governmental funds with similar information presented for governmental activities in the government-wide financial statements. By doing so, readers may better understand the long-term impact of the government's near-term financing decisions. Both the governmental fund balance sheet and the governmental fund statement of revenues, expenditures, and changes in fund balances provide a reconciliation to facilitate this comparison between governmental funds and governmental activities.

The County maintains 15 individual governmental funds. Information is presented separately in the Governmental Fund Balance Sheet and in the Governmental Fund Statement of Revenues, Expenditures and Changes in Fund Balances for the General Fund, Grant Fund and Unit Road Fund, which are considered to be major funds. Data from the other 12 funds are combined into a single, aggregated presentation. Individual fund data for each of the non-major governmental funds is provided in the form of combining statements elsewhere in this report.

Fiduciary Funds. Fiduciary funds account for assets held by the County in a trustee capacity or as an agent on behalf of others.

Notes to Financial Statements. The notes provide additional information that is essential to gain a full understanding of the data provided in the government-wide, fund financial statements and fiduciary fund statements.

Other Information. In addition to the basic financial statements and accompanying notes, this report also presents other supplementary information following the notes to the financial statements. The other supplementary information includes combining and individual statements and schedules.

Government-wide Financial Analysis

At the end of fiscal year 2018, the County's net position (assets exceeding liabilities) totaled \$30,341,539. This analysis focuses on the net position (Table 1) and changes in net position (Table 2). This is an increase of \$3,450,919 in net position for fiscal year 2018.

Net Position. The largest portion of the County's net position, \$12,541,448 or 41.33%, reflects its investment in capital assets (land, buildings, infrastructure, machinery and equipment, construction in progress), less accumulated depreciation and any related debt used to acquire those assets that is still outstanding. The County uses these assets to provide services to its citizens; consequently, these assets are not available for future spending. Although the County reports its capital assets net of related debt, the resources needed to repay this debt must be provided from other sources, since the capital assets themselves cannot be used to liquidate these liabilities.

Net position of \$1,108,020 or 3.65%, in the debt service fund, are restricted for future debt service payments.

The remaining balance of unrestricted net assets, \$16,692,071 or 55.02%, may be used to meet the government's ongoing obligations to citizens and creditors.

CALDWELL COUNTY, TEXAS
MANAGEMENT'S DISCUSSION AND ANALYSIS
September 30, 2018

Table 1
Condensed Statement of Net Position

	<u>9/30/2018</u>	<u>9/30/2017</u>
ASSETS		
Current and other assets	\$ 30,089,712	\$ 20,589,813
Capital assets	24,235,251	24,365,814
Net pension assets	702,410	5,065
Total assets	<u>55,027,373</u>	<u>44,960,692</u>
DEFERRED OUTFLOWS OF RESOURCES		
Deferred charge on refunding	68,391	78,524
Deferred pension expense	1,095,353	1,360,376
	<u>1,163,744</u>	<u>1,438,900</u>
LIABILITIES		
Long-term liabilities	17,986,945	12,783,788
Other liabilities	6,817,233	6,195,233
Total liabilities	<u>24,804,178</u>	<u>18,979,021</u>
DEFERRED INFLOWS OF RESOURCES		
Unearned revenue	11,155	282,417
Deferred pension inflows	1,034,245	247,534
	<u>1,045,400</u>	<u>529,951</u>
NET POSITION		
Net Investment in capital assets	12,541,448	12,611,185
Restricted	1,108,020	1,164,953
Unrestricted	16,692,071	13,114,482
	<u>\$ 30,341,539</u>	<u>\$ 26,890,620</u>

Changes in Net Position. The net position of the County increased by \$3,450,919 for the fiscal year ended September 30, 2018. Table 2 itemizes the changes from fiscal year 2017 to fiscal year 2018. Increases in revenues over the prior fiscal year primarily resulted from county services, capital grants, and taxes. The overall decrease in expenditures from the prior fiscal year is primarily tied to lapses in staffing, and the related personnel costs, throughout fiscal year 2018.

CALDWELL COUNTY, TEXAS
MANAGEMENT'S DISCUSSION AND ANALYSIS
September 30, 2018

Table 2
Changes in Net Position

	<u>9/30/2018</u>	<u>9/30/2017</u>
Program Revenues:		
Charges for services	\$ 4,158,517	\$ 5,177,191
Operating grants and contributions	306,597	481,399
Capital grant and contributions	962,605	5,932,592
General Revenues		
Taxes	18,742,113	15,475,662
Unrestricted investment earnings	254,132	102,539
Miscellaneous	135,245	104,776
Gain (loss) on sale of capital assets	44,339	63,012
Special item inflow	-	577,093
Total Revenues	<u>24,603,548</u>	<u>27,914,264</u>
Expenses:		
General Administration	3,414,732	3,728,873
Judicial	2,243,260	2,229,987
Legal	965,159	915,739
Financial Administration	1,353,204	1,219,377
Public Facilities	556,193	609,908
Public Safety	7,478,049	7,484,768
Public Transportation	3,763,636	9,076,723
Environmental Protection	70,618	67,384
Health and Welfare	686,841	646,784
Conservation and agriculture	108,510	101,709
Interest on long-term debt	512,427	418,265
Total Expenses	<u>21,152,629</u>	<u>26,499,517</u>
Increase/Decrease in net position	3,450,919	1,414,747
Net position-October 1	26,890,620	25,475,873
Net position-September 30	<u>\$ 30,341,539</u>	<u>\$ 26,890,620</u>

Financial Analysis of the Government's Funds

Government funds. The focus of the County's governmental funds is to provide information on near-term inflows, outflows and balances of spendable resources. Such information is useful in assessing the County's financing requirements. In particular, unreserved fund balances may serve as a useful measure of the government's net resources available for spending at the end of the fiscal year.

As of the end of the current fiscal year, the County's governmental funds reported combined fund balances of \$19,129,657.

CALDWELL COUNTY, TEXAS
MANAGEMENT'S DISCUSSION AND ANALYSIS
September 30, 2018

The General Fund is the main operating fund of the County. At the end of the current fiscal year, fund balance was \$10,661,374. This is an increase of \$2,646,284 from last year.

General Fund Budgetary Highlights. Each year the County performs periodic reviews of the budget. Budget amendments are approved throughout the year transferring amounts from one line item to another budgeted item.

Discussion of revenue variances follows:

Tax revenues include an increase of \$120,982 above budget projections that are mainly attributed to an increase in in sales tax collections by 6.7% in comparison to the estimated revenue.

License and permit fees collected were \$159,934 less than budgeted due to a decline in motor vehicle registrations; however, a large portion of that decline was absorbed by a substantial increase in collections of boat registration fees, subdivision fees and sanitation permits.

Intergovernmental revenues resulted in a \$74,661 increase in comparison to this overall categorical budget due to the intergovernmental jail revenue, commissary reimbursement, and other Grant revenues defined.

Fees of office revenue have exceeded the estimated revenue by \$157,617. This is attributed to the increased collections on the behalf of the County Clerk fees, Court Reporter Fees, Tax Assessor Fees, JP#1 fees, JP#2 fees, JP#3 fees, Pre Trial Bond Fees, DPS Fees, Constable-PCT. 2, & 4 Fees, Traffic Fees, Inmate Telephone Fees, and Birth Record Fees.

Fines came in higher than the overall budget by \$174,435 due to the collections within the Justice of the Peace offices and Bond Forfeitures all being major revenue contributors.

Miscellaneous revenue was \$91,065 less than the amended budgeted. Income consists primarily of miscellaneous items, reimbursed items, rental revenues and insurance proceeds; these items are difficult to budget.

Overall, the estimated revenues of \$20,389,453 were amended totaling \$20,613,774, \$224,321 or 1.1% more than the original budget. The actual revenues at the end of the fiscal year totaled \$494,510 or 2.40% higher than the amended budgeted.

Discussion on expenditures follows:

The General Administration consists of increasing total appropriation with budget adjustment(s) totaling \$10,410 and the actual expenditures \$410,252 below budget.

Judicial budget contains budget amendment(s) decreasing the budget totaling \$2,017 and the actual expenditures were below final budget by \$184,324 as a result of lower costs in the county and district courts.

Legal managed actual expenditures of \$39,870 below the final appropriation.

The Financial Administration budget was not amended and the actual expenditures of \$56,103 came in below the final budget.

The Public Facilities budget amendment(s) resulted in an overall increase of \$5,639 and the actual expenditures came in below the \$135,920 less in expenditures than budgeted.

Public Safety's budget was increased with budget amendment(s) totaling \$54,624, but ending with a positive variance of coming below actual versus budget by \$692,085 due to turnover in staff and other related issues.

CALDWELL COUNTY, TEXAS
MANAGEMENT'S DISCUSSION AND ANALYSIS
 September 30, 2018

Environmental protection actual costs were below budget by \$15,936.

The Health and Welfare budget did not require any budget adjustments and the overall expenditures remained below budget by \$123,560.

Conservation-Agriculture came in \$2,460 under budget due to the failure to maintain full staffing reducing personnel and related costs.

Overall, the original budget was \$16,972,797 and was amended to \$17,041,453, increasing it by \$68,656 or .40 % of appropriations. The actual expenditures at the end of the fiscal year totaled \$15,380,943, \$1,660,510 or 9.74% less than the amended budget.

Grant Fund Budgetary Highlights.

Caldwell County did not meet the criteria and/or meet the threshold to have a single audit.

Unit Road Fund Budgetary Highlights.

Unit Road actual revenues were \$996,009. Transfer In of \$2,794,869 is necessary to supplement Unit Road's resources, making up the majority of the financing source of the fund. The Transfer In was to match the revenue with the actual expenditures which were performed in the Unit Road fund. The actual expenditures included \$3,406,597.

Capital Assets and Debt Administration

Capital Assets. The County's investment in capital assets as of September 30, 2018, amounts to \$24,365,251 (net of accumulated depreciation). The investment in capital assets includes land, buildings, machinery and equipment, and infrastructure.

Table 3
Capital Assets at Year End
Net of Accumulated Depreciation

	9/30/2018	9/30/2017
Land	\$ 553,432	\$ 553,432
Construction in progress	-	-
Buildings and improvements	20,980,486	21,566,854
Machinery and equipment	1,979,225	1,331,993
Infrastructure	722,108	913,535
	\$ 24,235,251	\$ 24,365,814

Additional information on the County's capital assets can be found in the notes to the financial statements at page 32.

CALDWELL COUNTY, TEXAS
MANAGEMENT'S DISCUSSION AND ANALYSIS
September 30, 2018

Debt Administration. At the end of the current fiscal year, Caldwell County had total debt outstanding of \$17,542,225. Of this amount, \$4,325,000 is comprised of Certificates of Obligation, with principal due annually through 2029 with interest due semiannually. All debt is backed by the full faith and credit of Caldwell County.

Table 4
Outstanding Debt at Year End

<u>Type of Debt</u>	<u>9/30/2018</u>	<u>9/30/2017</u>
Certificates of obligation	\$ 3,950,000	\$ 4,325,000
Limited tax refunding bonds	7,505,000	7,945,000
Combined limited pledge certificates of obligation	5,955,000	-
Premium on bonds issued	132,225	3,154
Net General Obligation Bonds	<u>17,542,225</u>	<u>12,273,154</u>
Compensated Absences	444,720	449,433
Net Pension (Asset) Liability	<u>(702,410)</u>	<u>61,201</u>
Total	<u>\$ 17,284,535</u>	<u>\$ 12,783,788</u>

Additional information on the County’s long-term debt can be found in the notes to the financial statements beginning at page 33.

The County’s total outstanding debt increased overall by \$4,500,747, predominately due to issuing new debt that was needed to facilitate major needs in Caldwell County to assist in maintaining the roads and compliance on departmental issues.

Economic Factors and Next Year’s Budgets and Rates

With several major developments planned for the area Caldwell County is poised for a significant growth in the tax base over the next several years. Investments in infrastructure will be required as well as a cohesive strategy for managing this growth.

Some key factors to look for in future budgets:

With anticipated growth in the rural areas of Caldwell County there will be significant needs throughout the County.

A strategic plan aligned with performance measures on departmental budgets assisting in the accountability of overall performance and maintenance of budget versus actual revenues and/or expenditures within their budgets may be considered.

Capital Improvement Projects may be aligned with a strategic plan. (i.e. what major improvements are needed for Unit Road Department in Capital and/or road maintenance and improvement; fleet policy and/or funding mechanism needs put in place for a systematic retention and replacement of all county vehicles and equipment.)

Continued increase in health insurance due to rising health care costs of County employees.

CALDWELL COUNTY, TEXAS
MANAGEMENT'S DISCUSSION AND ANALYSIS
September 30, 2018

Requests for Information

This financial report is designed to provide a general overview of Caldwell County's finances for all those with an interest in the government's finances. Questions concerning any of the information provided in this report or requests for additional financial information should be addressed to the County Auditor's Office, 110 S. Main St, Room 303, Lockhart, Texas, 78644.

Basic Financial Statements

CALDWELL COUNTY, TEXAS
STATEMENT OF NET POSITION
SEPTEMBER 30, 2018

	Governmental Activities
ASSETS:	
<i>Cash and cash equivalents</i>	\$ 19,373,919
<i>Receivables (net of allowances for uncollectibles):</i>	
<i>Taxes</i>	1,643,441
<i>Fines</i>	7,324,244
<i>Accounts</i>	16,059
<i>Intergovernmental</i>	958,569
<i>Due from Fiduciary</i>	645,236
<i>Inventories</i>	112,429
<i>Prepaid items</i>	15,815
<i>Capital assets (net of accumulated depreciation):</i>	
<i>Land</i>	553,432
<i>Buildings and improvements</i>	20,980,486
<i>Machinery and equipment</i>	1,979,225
<i>Infrastructure</i>	722,108
<i>Net pension asset</i>	702,410
Total Assets	55,027,373
DEFERRED OUTFLOW OF RESOURCES	
<i>Deferred charge on refunding</i>	68,391
<i>Deferred pension expense</i>	1,095,353
Total Deferred Outflow of Resources	1,163,744
LIABILITIES:	
<i>Accounts payable</i>	962,502
<i>Accrued liabilities and other payables</i>	326,596
<i>Due to other governments</i>	4,283,939
<i>Due to others</i>	1,244,196
<i>Noncurrent Liabilities-</i>	
<i>Due within one year</i>	958,030
<i>Due in more than one year</i>	17,028,915
Total Liabilities	24,804,178
DEFERRED INFLOWS OF RESOURCES	
<i>Unearned revenue</i>	11,155
<i>Deferred pension inflow</i>	1,034,245
Total deferred inflow of resources	1,045,400
NET POSITION:	
<i>Net Investment in Capital Assets</i>	12,541,448
<i>Restricted For:</i>	
<i>Debt Service</i>	1,108,020
<i>Unrestricted</i>	16,692,071
Total Net Position	\$ 30,341,539

The accompanying notes are an integral part of this statement.

CALDWELL COUNTY, TEXAS
STATEMENT OF ACTIVITIES
FOR THE YEAR ENDED SEPTEMBER 30, 2018

Functions/Programs	Expenses	Program Revenues			Net (Expense) Revenue and Changes in Net Position
		Charges for Services	Operating Grants and Contributions	Capital Grants and Contributions	
PRIMARY GOVERNMENT:					
Governmental Activities:					
<i>General administration</i>	\$ 3,414,732	\$ 455,360	\$ 55,577	\$ 12,030	\$ (2,891,765)
<i>Judicial</i>	2,243,260	1,544,472	136,866	--	(561,922)
<i>Legal</i>	965,159	47,159	--	48,010	(869,990)
<i>Financial administration</i>	1,353,204	492,132	--	--	(861,072)
<i>Public facilities</i>	556,193	--	--	--	(556,193)
<i>Public safety</i>	7,478,049	1,319,677	114,154	--	(6,044,218)
<i>Public transportation</i>	3,763,636	42,079	--	902,565	(2,818,992)
<i>Environmental protection</i>	70,618	257,638	--	--	187,020
<i>Health and welfare</i>	686,841	--	--	--	(686,841)
<i>Conservation - agriculture</i>	108,510	--	--	--	(108,510)
<i>Interest on long-term debt</i>	512,427	--	--	--	(512,427)
Total Governmental Activities	<u>21,152,629</u>	<u>4,158,517</u>	<u>306,597</u>	<u>962,605</u>	<u>(15,724,910)</u>
Total Primary Government	<u>\$ 21,152,629</u>	<u>\$ 4,158,517</u>	<u>\$ 306,597</u>	<u>\$ 962,605</u>	<u>(15,724,910)</u>
General Revenues:					
<i>Advalorem taxes</i>					16,536,151
<i>Sales taxes</i>					1,825,049
<i>Automobile taxes</i>					364,325
<i>Alcoholic beverage taxes</i>					16,588
<i>Miscellaneous</i>					135,245
<i>Unrestricted investment earnings</i>					254,132
<i>Gain (loss) on disposal of capital assets</i>					44,339
<i>Transfers</i>					--
Total General Revenues and Transfers					<u>19,175,829</u>
Change in Net Position					<u>3,450,919</u>
Net Position - Beginning					<u>26,890,620</u>
Net Position - Ending					<u>\$ 30,341,539</u>

The accompanying notes are an integral part of this statement.

CALDWELL COUNTY, TEXAS
BALANCE SHEET - GOVERNMENTAL FUNDS
SEPTEMBER 30, 2018

	General Fund	Building Construction
ASSETS		
Assets:		
<i>Cash and cash equivalents</i>	\$ 11,420,666	\$ 6,279,860
<i>Receivables (net of allowances for uncollectibles):</i>		
Taxes	1,482,315	--
Fines	7,324,244	--
Accounts	16,059	--
Intergovernmental	527,915	--
<i>Due from other funds</i>	--	--
<i>Due from agency funds</i>	--	--
<i>Inventories</i>	1,434	--
<i>Prepaid items</i>	15,815	--
Total Assets	\$ 20,788,448	\$ 6,279,860
LIABILITIES DEFERRED INFLOWS OF RESOURCES, AND FUND BALANCES		
Liabilities:		
<i>Accounts Payable</i>	\$ 286,908	\$ 499,829
<i>Accrued liabilities and other payables</i>	253,776	--
<i>Due to Other Funds</i>	--	--
<i>Due to other governments</i>	4,283,939	--
<i>Due to others</i>	1,244,196	--
Total Liabilities	6,068,819	499,829
Deferred Inflows of Resources		
<i>Deferred tax revenue</i>	1,371,995	--
<i>Deferred fine revenue</i>	2,676,905	--
<i>Deferred grant revenue</i>	9,355	--
Total deferred inflows of resources	4,058,255	--
Fund Balances:		
<i>Nonspendable</i>	17,249	--
<i>Restricted</i>	--	5,780,031
<i>Committed</i>	216,500	--
<i>Assigned</i>	--	--
<i>Unassigned</i>	10,427,625	--
Total Fund Balance	10,661,374	5,780,031
Total Liabilities, Deferred Inflows of Resources, and Fund Balance	\$ 20,788,448	\$ 6,279,860

The accompanying notes are an integral part of this statement.

EXHIBIT A-3

Unit Road Fund	Other Governmental Funds	Total Governmental Funds
\$ 221,302	\$ 1,452,092	\$ 19,373,920
21	161,105	1,643,441
--	--	7,324,244
--	--	16,059
327,764	102,890	958,569
509,104	--	509,104
645,236	--	645,236
110,995	--	112,429
--	--	15,815
<u>\$ 1,814,422</u>	<u>\$ 1,716,087</u>	<u>\$ 30,598,817</u>
\$ 174,375	\$ 1,390	\$ 962,502
5,033	--	258,809
--	509,104	509,104
--	--	4,283,939
--	--	1,244,196
<u>179,408</u>	<u>510,494</u>	<u>7,258,550</u>
4	150,551	1,522,550
--	--	2,676,905
--	1,800	11,155
<u>4</u>	<u>152,351</u>	<u>4,210,610</u>
110,995	--	128,244
--	1,396,932	7,176,963
--	64,809	281,309
1,524,015	--	1,524,015
--	(408,499)	10,019,126
<u>1,635,010</u>	<u>1,053,242</u>	<u>19,129,657</u>
<u>\$ 1,814,422</u>	<u>\$ 1,716,087</u>	<u>\$ 30,598,817</u>

This page is left blank intentionally.

CALDWELL COUNTY, TEXAS

RECONCILIATION OF THE GOVERNMENTAL FUNDS BALANCE SHEET
 TO THE STATEMENT OF NET POSITION
 SEPTEMBER 30, 2018

Total fund balances - governmental funds balance sheet	\$ 19,129,657
Amounts reported for governmental activities in the Statement of Net Position are different because:	
Capital assets used in governmental activities are not reported in the funds.	24,235,251
Property taxes receivable unavailable to pay for current period expenditures are deferred in the funds.	1,522,550
Payables for bond principal which are not due in the current period are not reported in the funds.	(17,542,225)
Payables for bond interest which are not due in the current period are not reported in the funds.	(67,787)
Payables for compensated absences which are not due in the current period are not reported in the funds.	(444,720)
Other long-term assets are not available to pay for current period expenditures and are deferred in the funds.	68,391
Court fines receivable unavailable to pay for current period expenditures are deferred in the funds.	2,676,904
Recognition of the County's net pension asset is not reported in the funds.	702,410
Deferred Resource Inflows related to the pension plan are not reported in the funds.	(1,034,245)
Deferred Resource Outflows related to the pension plan are not reported in the funds.	<u>1,095,353</u>
Net position of governmental activities - Statement of Net Position	<u>\$ 30,341,539</u>

The accompanying notes are an integral part of this statement.

CALDWELL COUNTY, TEXAS**STATEMENT OF REVENUES, EXPENDITURES, AND CHANGES
IN FUND BALANCES - GOVERNMENTAL FUNDS
FOR THE YEAR ENDED SEPTEMBER 30, 2018**

	General Fund	Building Construction
Revenue:		
<i>Taxes</i>	\$ 16,903,493	\$ --
<i>Licenses and permits</i>	596,066	--
<i>Intergovernmental</i>	1,347,255	--
<i>Fees of office</i>	992,867	--
<i>Fines</i>	931,435	--
<i>Miscellaneous</i>	109,354	9,462
<i>Investment earnings</i>	227,814	--
Total revenues	<u>21,108,284</u>	<u>9,462</u>
Expenditures:		
Current:		
<i>General administration</i>	2,465,447	499,829
<i>Judicial</i>	1,815,669	--
<i>Legal</i>	925,328	--
<i>Financial administration</i>	1,328,677	--
<i>Public facilities</i>	540,975	--
<i>Public safety</i>	7,449,362	--
<i>Public transportation</i>	--	--
<i>Environmental protection</i>	64,889	--
<i>Health and welfare</i>	684,721	--
<i>Conservation - agriculture</i>	105,875	--
Debt Service:		
<i>Principal</i>	--	--
<i>Interest and fiscal charges</i>	--	--
<i>Bond issuance costs</i>	--	85,847
Total Expenditures	<u>15,380,943</u>	<u>585,676</u>
Excess (Deficiency) of Revenues Over (Under) Expenditures	<u>5,727,341</u>	<u>(576,214)</u>
Other Financing Sources (Uses):		
<i>Transfers in</i>	24,441	--
<i>Transfers out</i>	(3,240,235)	--
<i>Proceeds of bond issue</i>	--	5,955,000
<i>Premiums on bonds sold</i>	--	132,605
<i>Insurance proceeds</i>	90,397	--
<i>Sale of capital assets</i>	44,340	--
Total Other Financing Sources (Uses)	<u>(3,081,057)</u>	<u>6,087,605</u>
Net Change in Fund Balances	2,646,284	5,511,391
Fund Balances - Beginning	8,015,090	268,640
Fund Balances - Ending	<u>\$ 10,661,374</u>	<u>\$ 5,780,031</u>

The accompanying notes are an integral part of this statement.

EXHIBIT A-5

Unit Road Fund	Other Governmental Funds	Total Governmental Funds
\$ 366,830	\$ 1,416,605	\$ 18,686,928
42,079	--	638,145
565,193	457,108	2,369,556
--	271,107	1,263,974
--	18,125	949,560
21,907	6,649	147,372
--	16,336	244,150
<u>996,009</u>	<u>2,185,930</u>	<u>24,299,685</u>
--	662,840	3,628,116
--	122,887	1,938,556
--	19,140	944,468
--	--	1,328,677
--	--	540,975
--	15,940	7,465,302
3,406,597	118,052	3,524,649
--	--	64,889
--	--	684,721
--	--	105,875
--	816,830	816,830
--	402,822	402,822
--	--	85,847
<u>3,406,597</u>	<u>2,158,511</u>	<u>21,531,727</u>
<u>(2,410,588)</u>	<u>27,419</u>	<u>2,767,958</u>
2,794,869	445,366	3,264,676
--	(24,441)	(3,264,676)
--	--	5,955,000
--	--	132,605
--	--	90,397
--	--	44,340
<u>2,794,869</u>	<u>420,925</u>	<u>6,222,342</u>
384,281	448,344	8,990,300
1,250,729	604,898	10,139,357
<u>\$ 1,635,010</u>	<u>\$ 1,053,242</u>	<u>\$ 19,129,657</u>

This page is left blank intentionally.

CALDWELL COUNTY, TEXAS

*RECONCILIATION OF THE STATEMENT OF REVENUES, EXPENDITURES,
AND CHANGES IN FUND BALANCES OF GOVERNMENTAL FUNDS
TO THE STATEMENT OF ACTIVITIES
FOR THE YEAR ENDED SEPTEMBER 30, 2018*

Net change in fund balances - total governmental funds	\$ 8,990,300
Amounts reported for governmental activities in the Statement of Activities ("SOA") are different because:	
Capital outlays are not reported as expenses in the SOA.	1,154,730
The depreciation of capital assets used in governmental activities is not reported in the funds.	(1,285,293)
Certain property tax revenues are deferred in the funds. This is the change in these amounts this year.	38,593
Repayment of bond principal is an expenditure in the funds but is not an expense in the SOA.	815,000
Bond issuance costs and similar items are amortized in the SOA but not in the funds.	(15,198)
(Increase) decrease in accrued interest from beginning of period to end of period.	(6,730)
Compensated absences are reported as the amount earned in the SOA but as the amount paid in the funds.	4,713
Certain fine revenues are deferred in the funds. This is the change in these amounts this year.	130,532
Proceeds of bonds do not provide revenue in the SOA, but are reported as current resources in the funds.	(5,955,000)
Bond premiums are reported in the funds but not in the SOA.	(132,605)
Pension expense relating to GASB 68 is recorded in the SOA but not in the funds.	(288,122)
Change in net position of governmental activities - Statement of Activities	<u>\$ 3,450,919</u>

The accompanying notes are an integral part of this statement.

CALDWELL COUNTY, TEXAS
STATEMENT OF FIDUCIARY NET POSITION
FIDUCIARY FUNDS
SEPTEMBER 30, 2018

	Agency Funds
ASSETS:	
<i>Cash and cash equivalents</i>	\$ 2,730,704
<i>Other receivables</i>	3,051
<i>Intergovernmental</i>	304,605
Total Assets	\$ <u>3,038,360</u>
LIABILITIES:	
<i>Accounts payable</i>	\$ 82,690
<i>Due to governmental funds</i>	645,236
<i>Due to other governments</i>	131,749
<i>Due to others</i>	2,178,685
Total Liabilities	\$ <u>3,038,360</u>

The accompanying notes are an integral part of this statement.

CALDWELL COUNTY, TEXAS
NOTES TO THE FINANCIAL STATEMENTS
YEAR ENDED SEPTEMBER 30, 2018

I. SUMMARY OF SIGNIFICANT ACCOUNTING POLICIES

A. Reporting Entity

The County, a political subdivision of the State of Texas is governed by an elected judge and four county commissioners which comprise the commissioners' court. The county's operational activities include general administrative services, judicial, legal, financial administration, public facilities, public safety, public transportation, environmental protection, health and welfare assistance, conservation - agriculture services.

The accounting policies of Caldwell County, Texas, conform to generally accepted accounting principals issued by the Governmental Accounting Standards Board which is the recognized financial accounting standard setting body for governmental entities. The notes to the financial statements are an integral part of the County's basic financial statements.

The accompanying basic financial statements comply with the provisions of the GASB Statement No. 14, "The Financial Reporting Entity," in that the financial statements include all organizations, activities, functions and component units for which the County (the "primary government") is financially accountable. Financial accountability is defined as the appointment of a voting majority of a legally separate organization's governing body and either (1) the County's ability to impose its will over the organization, or (2) the potential that the organization will provide a financial benefit to or impose a financial burden on the County.

There are no component units which satisfy requirements for blending or discrete presentation within the County's financial statements. Accordingly, the basic financial statements present the County only.

B. Government-wide and Fund Financial Statements

The government-wide financial statements (i.e. the statement of net assets and the statement of position) report information on all of the nonfiduciary activities of the government. For the most part, the effect of interfund activity has been removed from these statements. *Governmental activities* are supported by taxes, charges for services, and intergovernmental revenues.

The statement of activities demonstrates the degree to which the direct expenses of a given function or segment are offset by program revenues. *Direct expenses* are those that are clearly identifiable with a specific function or segment. *Program revenues* include 1) charges to customers or applicants who purchase, use, or directly benefit from goods, services, or privileges provided by a given function or segment and 2) grants and contributions that are restricted to meeting the operational or capital requirements of a particular function or segment. Taxes and other items not properly included among program revenues are reported instead as *general revenues*.

Separate financial statements are provided for governmental funds, and fiduciary funds, even though the latter are excluded from the government-wide financial statements.

C. Measurement Focus, Basis of Accounting, and Financial Statement Presentation

The government-wide financial statements are reported using the *economic resources measurement focus and the accrual basis of accounting*, as are the proprietary fund and fiduciary fund financial statements. Revenues are recorded when earned and expenses are recorded when a liability is incurred, regardless of the timing of related cash flows. Property taxes are recognized as revenues in the year for which they are levied. Grants and similar items are recognized as revenue as soon as all eligibility requirements imposed by the provider have been met.

CALDWELL COUNTY, TEXAS
NOTES TO THE FINANCIAL STATEMENTS
YEAR ENDED SEPTEMBER 30, 2018

Governmental fund financial statements are reported using the *current financial resources measurement focus* and the *modified accrual basis of accounting*. Revenues are recognized as soon as they are both measurable and available. Revenues are considered to be *available* when they are collectible within the current period or soon enough thereafter to pay liabilities of the current period. For this purpose, the County considers revenues to be available if they are collected within 60 days of the end of the current fiscal period. Expenditures generally are recorded when a liability is incurred, as under accrual accounting. However, debt service expenditures, as well as expenditures related to compensated absences and claims and judgments, are recorded only when payment is due.

Property taxes and interest associated with the current fiscal period are all considered to be susceptible to accrual and so have been recognized as revenues of the current fiscal period. Fines and permits, and miscellaneous revenues are not susceptible to accrual because generally they are not measurable until received in cash.

The County reports the following major governmental funds:

The *General Fund* is the County's primary operating fund. It accounts for all financial resources of the general government, except those required to be accounted for in another fund.

The *Building Construction Fund* accounts for construction projects financed by the proceeds of a bond issue.

The *Grant Fund* accounts for certain major grants received from the federal and state governments and expenditures related to specific purposes of the grants.

The *Unit Road Fund* accounts for certain revenues and expenditures related to the construction and maintenance of roads and bridges within the County. Primary revenues of this fund are ad valorem taxes, licenses and permits, and transfers from the General Fund.

Additionally, the County reports the following fund types:

The Special Revenue Funds account for specific revenue sources that are legally restricted to expenditures for specified purposes (not including private purpose trusts or major capital projects).

The *Debt Service Fund* accounts for the accumulation of resources to be used for the payment of principal and interest.

The *Building Construction Capital Projects Fund* accounts for residual amounts from the proceeds of the 2010 Certificates of Obligation, the 2012 Short Term Tax Notes, and the 2013 Short Term Tax Notes issued to construct and remodel County buildings.

Agency Funds are used to account for assets held by the government as an agent for individuals, private organizations, other governments, and/or other agency funds.

As a general rule the effect of interfund activity has been eliminated from the government-wide financial statements.

Amounts reported as *program revenues* include 1) charges to customers or applicants for goods, services, or privileges provided, 2) operating grants and contributions, and 3) capital grants and contributions, including special assessments. Internally dedicated resources are reported as *general revenues* rather than as program revenues. Likewise, general revenues include all taxes, miscellaneous revenue, and interest income.

D. Assets, liabilities, and net assets or equity

1. Deposits and investments

The County's cash and cash equivalents are considered to be cash on hand, demand deposits, and short-term investments with original maturities of three months or less from the date of acquisition.

State statutes authorize the County to invest in (1) obligations of the United States or its agencies and instrumentalities; (2) direct obligations of the State of Texas or its agencies; (3) other obligations, the principal of and interest on which are unconditionally guaranteed or insured by the State of Texas or the

CALDWELL COUNTY, TEXAS
NOTES TO THE FINANCIAL STATEMENTS
YEAR ENDED SEPTEMBER 30, 2018

United States; (4) obligations of states, agencies, counties, cities, and other political subdivisions of any state having been rated as to investment quality by a nationally recognized investment rating firm and having received a rating of not less than A or its equivalent; (5) certificates of deposit by state and national banks domiciled in this state that are (A) guaranteed or insured by the Federal Deposit Insurance Corporation, or its successor; or, (B) secured by obligations that are described by (1) - (4); or, (6) fully collateralized direct repurchase agreements having a defined termination date, secured by obligations described by (1), pledged with third party selected or approved by the County, and placed through a primary government securities dealer.

Investments maturing within one year of date of purchase are stated at cost or amortized cost, all other investments are stated at fair value which is based on quoted market prices.

2. Receivables and payables

Activity between funds that are representative of lending/borrowing arrangements outstanding at the end of the fiscal year are referred to as either "due to/from other funds" (i.e., the current portion of interfund loans) or "advances to/from other funds" (i.e., the non-current portion of interfund loans). All other outstanding balances between funds are reported as "due to/from other funds." Any residual balances outstanding between the governmental activities and business-type activities are reported in the government-wide financial statements as "internal balances."

Advances between funds, as reported in the fund financial statements, are offset by a fund balance reserve account in applicable governmental funds to indicate that they are not available for appropriation and are not expendable available financial resources.

Fines receivables are shown net of an allowance for uncollectibles. The allowance for uncollectibles is an estimate based upon experience.

Property taxes are levied on October 1 by the County based on the January 1 property values as appraised by the County Central Appraisal District. Taxes are due without penalty until January 31, of the next calendar year. After January 31 the County has an enforceable lien with respect to both real and personal property. Under state law, property taxes levied on real property constitute a perpetual lien on the real property which cannot be forgiven without specific approval of the State Legislature. Taxes applicable to personal property can be deemed uncollectible by the County.

3. Inventories and prepaid items

Inventories are valued at cost using the first in/first out (FIFO) method. Inventories of governmental funds are recorded as expenditures when consumed rather than purchased.

Certain payments to vendors reflect costs applicable to future accounting periods and are recorded as prepaid items in both the government-wide and fund financial statements.

4. Capital assets

Capital assets, which include property, plant, equipment, and infrastructure assets (e.g., roads, bridges, and similar items), are reported in the governmental activities column in the government-wide financial statements. Capital assets are defined by the County as assets with an initial, individual cost of more than \$5,000 (amount not rounded) and an estimated useful life in excess of one year. Such assets are recorded at historical cost or estimated historical cost if purchased or constructed. Donated capital assets are recorded at estimated fair market value at the date of donation.

The costs of normal maintenance and repairs that do not add to the value of the asset or materially extend assets lives are not capitalized.

Major outlays for capital assets and improvements are capitalized as projects are constructed.

CALDWELL COUNTY, TEXAS
NOTES TO THE FINANCIAL STATEMENTS
YEAR ENDED SEPTEMBER 30, 2018

Property, plant, and equipment of the primary government is depreciated using the straight line method over the following estimated useful lives:

Buildings	50 years
Building improvements	20 years
Infrastructure	30 years
Machinery and Equipment	5 - 10 years

5. Compensated absences

Employees accumulate earned but unused vacation and compensatory time. All vacation and compensatory pay is accrued when incurred in the government-wide funds. A liability is reported for these amounts in governmental funds only if they have matured, for example, as a result of employee resignations and retirements.

6. Long-term obligations

In the government-wide financial statements long-term debt and other long-term obligations are reported as liabilities in the applicable governmental activities statement of net assets. Bond premiums and discounts, as well as bond insurance costs, are deferred and amortized over the life of the bonds using the straight line method which approximate the effective interest method. Bonds payable are reported net of the applicable bond premium or discount.

In the fund financial statements, governmental fund types recognize bond premiums and discounts, as well as bond issuance and insurance costs, during the current period. The face amount of debt issued is reported as other financing sources. Premiums received on debt issuances are reported as other financing sources while discounts on debt issuances are reported as other financing uses. Insurance costs, whether or not withheld from the actual debt proceeds received, are reported as debt service expenditures.

7. Fund equity

Nonspendable Fund Balance Amounts that cannot be spent because they are either not in a spendable form or are legally or contractually required to be maintained intact.

Restricted Fund Balance - Amounts that can be spent only for specific purposes because of constraints imposed by external providers, or imposed by constitutional provisions or enabling legislation.

Committed Fund Balance - Amounts that can only be used for specific purposes pursuant to constraints imposed by the Commissioner's Court through legislation, resolution or Court order, unless the Commissioner's Court removes or changes the specified use by taking the same type of action used to commit the amounts.

Assigned Fund Balance - Amounts that are constrained by the Commissioner's Court, or by another County official or the finance division to which the Court has delegated authority, that are to be used for specific purposes but are neither restricted nor committed.

Unassigned Fund Balance - Amounts that are available for any purpose; these amounts can be reported only in the County's General Fund.

Fund balance amounts represent the nature of the net resources that are reported in a governmental fund. When the County incurs an expenditure and both restricted and unrestricted amounts are available, the County considers restricted amounts to have been spent. When the County incurs an expenditure for an unrestricted amount, committed amounts are reduced first, followed by assigned amounts and then unassigned amounts for purposes in which any of those unrestricted fund balance classifications could be used.

CALDWELL COUNTY, TEXAS
NOTES TO THE FINANCIAL STATEMENTS
YEAR ENDED SEPTEMBER 30, 2018

	General	Building	Unit	Other	
	Fund	Construction	Road	Funds	Total
Fund Balances					
Nonspendable for:					
Inventory	\$ --	\$ --	\$110,995	\$ --	\$110,995
Prepaid items	17,249	--	--	--	17,249
	<u>17,249</u>	<u>--</u>	<u>110,995</u>	<u>--</u>	<u>128,244</u>
Restricted for:					
Debt service	--	--	--	957,469	957,469
Justice administration	--	--	--	60,587	60,587
Preservation	--	--	--	33,922	33,922
Construction	--	5,780,031	--	--	5,780,031
Other	--	--	--	344,954	344,954
	<u>--</u>	<u>5,780,031</u>	<u>--</u>	<u>1,396,932</u>	<u>7,176,963</u>
Committed to:					
Courthouse maintenance	148,500	--	--	--	148,500
Disaster reaction	68,000	--	--	--	68,000
Hot check	--	--	--	64,809	64,809
Other	--	--	--	--	--
	<u>216,500</u>	<u>--</u>	<u>--</u>	<u>64,809</u>	<u>281,309</u>
Assigned	--	--	1,524,015	--	1,524,015
Unassigned	10,427,625	--	--	(408,499)	10,019,126
	<u>\$10,661,374</u>	<u>\$5,780,031</u>	<u>\$1,635,010</u>	<u>\$1,053,242</u>	<u>\$19,129,657</u>

CALDWELL COUNTY, TEXAS
NOTES TO THE FINANCIAL STATEMENTS
YEAR ENDED SEPTEMBER 30, 2018

II. DETAILED NOTES ON ALL FUNDS

A. Deposits and investments

Cash

At year end, the carrying amount of the County's cash on hand and deposits was \$4,561,442, including \$2,730,704 in agency funds. All of the bank balance of \$4,094,808, was covered by federal deposit insurance and collateralized by the pledging financial institution with marketable securities held by an agent in the bank's name. At year end the County's financial institution could not confirm that the pledged securities meet the criteria of the Financial Institutions Reform, Recovery, and Enforcement Act of 1989 as a valid security agreement against the FDIC.

Investments

As of September 30, 2018, the County had the following investments:

Investment type	Credit Rating*	Fair Value	Days to Maturity
Government sponsored investment pool (LOGIC)	AAAm	\$13,406,175	<60
Government sponsored investment pool (TexPool)	AAAm	2,973,849	<60
Government sponsored investment pool (Texas Class)	AAAm	1,163,157	<60
Total Fair Value		\$17,543,181	

* Standard and Poors

Interest Rate Risk. In accordance with its investment policy, the County manages its exposure to declines in fair value by limiting the weighted average maturity of its portfolio to less than three years.

Credit Risk. State law limits investments as described previously in Note I D.1.

Concentration of Credit Risk. The County's investment policy does not allow for an investment in any one issuer (other than investment pools) that is in excess of five percent of the fair value of the County's total investments.

Custodial Credit Risk – Deposits. In the case of deposits, this is the risk that in the event of a bank failure, the County's deposits may not be returned to it. The County requires all deposits to be covered by Federal Depository Insurance Corporation (FDIC) insurance and/or collateralized by qualified securities pledged by the County's depository in the County's name and held by the depository's agent.

Custodial Credit Risk – Investments. For an investment, this is the risk that, in the event of the failure of the counterparty, the County will not be able to recover the value of its investments or collateral securities that are in the possession of an outside party.

LOGIC, TexPool, and Texas Class are external investment pools and are not SEC registered. The Texas Interlocal Cooperation Act and the Texas Public Funds Investment Act provide for creation of public funds investments pools and permit eligible governmental entities to jointly invest their funds in authorized investments. The fair value of investments in the pools are independently reviewed monthly. At September 30, 2018 the fair value of the position in these pools approximates the fair value of the shares.

Cash	\$4,561,442
Investments	17,543,181
Total	\$22,104,623

Reported in the financial statements as:

Unrestricted cash and cash equivalents	\$19,373,919
Agency Funds	2,730,704
Total	\$22,104,623

CALDWELL COUNTY, TEXAS
NOTES TO THE FINANCIAL STATEMENTS
YEAR ENDED SEPTEMBER 30, 2018

B. Receivables

Receivables as of year-end for the government's individual major funds and nonmajor funds in the aggregate, including the applicable allowances for uncollectible accounts, are as follows:

	General	Grant	Unit Road	NonMajor and Other	Total
Taxes receivable	\$1,611,264	\$ --	\$530	\$177,127	\$1,788,921
Allowance	(128,949)	--	(509)	(16,022)	(145,480)
Net taxes receivable	<u>\$1,482,315</u>	<u>\$ --</u>	<u>\$21</u>	<u>\$161,105</u>	<u>\$1,643,441</u>
Fines receivable	\$14,345,202	\$ --	\$ --	\$ --	\$14,345,202
Allowance	(7,020,958)	--	--	--	(7,020,958)
Net fines receivable	<u>\$7,324,244</u>	<u>--</u>	<u>\$ --</u>	<u>\$ --</u>	<u>\$7,324,244</u>
Accounts receivable	<u>\$16,059</u>	<u>\$ --</u>	<u>\$ --</u>	<u>\$ --</u>	<u>\$16,059</u>
Intergovernmental	<u>\$527,915</u>	<u>\$ --</u>	<u>\$327,764</u>	<u>\$102,890</u>	<u>\$958,569</u>

Governmental funds report *deferred resource inflows* in connection with receivables for revenues that are not considered to be available to liquidate liabilities of the current period. Governmental funds also defer revenue recognition in connection with resources that have been received, but not yet earned. At the end of the current fiscal year, the various components of *deferred resource inflows* and *unearned revenue* reported in the governmental funds were as follows:

	Unavailable	Unearned	Total
Deferred tax revenue (General Fund)	\$1,371,995	\$ --	\$1,371,995
Deferred fines revenue (General Fund)	2,676,905	--	2,676,905
Deferred grant revenue (General Fund)	--	9,355	9,355
Deferred tax revenue (Unit Road)	4	--	4
Deferred grant revenue (Grant Fund)	--	1,800	1,800
Deferred tax revenue (Debt Service Fund)	150,551	--	150,551
Total deferred/unearned revenue for governmental funds	<u>\$4,199,455</u>	<u>\$11,155</u>	<u>\$4,210,610</u>

CALDWELL COUNTY, TEXAS
NOTES TO THE FINANCIAL STATEMENTS
YEAR ENDED SEPTEMBER 30, 2018

C. Capital assets

Capital asset activity for the year ended September 30, 2018:

	Balance 9/30/17	Additions	Retirements	Transfers	Balance 9/30/18
GOVERNMENTAL ACTIVITIES:					
Capital assets, not being depreciated:					
Land	\$553,432	\$ --	\$ --	\$ --	\$553,432
Construction in progress	--	--	--	--	--
Total capital assets not being	553,432	--	--	--	553,432
Capital assets, being depreciated:					
Buildings	28,693,593	--	--	--	28,693,593
Machinery and equipment	8,045,613	1,154,730	--	--	9,200,343
Infrastructure	14,357,002	--	--	--	14,357,002
Total capital assets being depreciated	51,096,208	1,154,730	--	--	52,250,938
Less accumulated depreciation for:					
Buildings	(7,126,739)	(586,368)	--	--	(7,713,107)
Machinery and equipment	(6,713,620)	(507,498)	--	--	(7,221,118)
Infrastructure	(13,443,467)	(191,427)	--	--	(13,634,894)
Total accumulated depreciation	(27,283,826)	(1,285,293)	--	--	(28,569,119)
Total capital assets being depreciated,	23,812,382	(130,563)	--	--	23,681,819
Governmental activities capital assets,	<u>\$24,365,814</u>	<u>(\$130,563)</u>	<u>\$ --</u>	<u>\$ --</u>	<u>\$24,235,251</u>

Depreciation expense was charged to functions/programs of the primary government as follows:

Governmental activities:	
General administration	\$323,196
Judicial	233,312
Financial administration	388
Public facilities	9,946
Public safety	392,801
Public transportation	325,650
Total depreciation expense - governmental activities	<u>\$1,285,293</u>

CALDWELL COUNTY, TEXAS
NOTES TO THE FINANCIAL STATEMENTS
YEAR ENDED SEPTEMBER 30, 2018

D. Interfund receivables, payables, and transfers

The composition of interfund balances as of September 30, 2018, is as follows:

Fund	Receivable	Payable
Major Funds		
Unit Road Fund	\$1,154,340	\$ --
Grant Fund	--	457,208
Total Major Funds	1,154,340	457,208
Nonmajor Funds		
Law Library	--	51,896
Total Nonmajor Funds	--	51,896
Total Governmental Funds	1,154,340	509,104
Agency Funds		
Unclaimed Money	--	172
Juvenile Probation	--	645,064
Total Funds	\$1,154,340	\$1,154,340

Interfund receivables are primarily the result of overdrafts in pooled cash.

E. Interfund Transfers

Fund	Transfer In	Transfer Out
Major Funds		
General Fund	\$24,441	\$3,240,235
Unit Road Fund	2,794,869	--
Total Major Funds	2,819,310	3,240,235
Non Major Governmental Funds		
Grant Fund	20,000	--
911	--	9,728
Special Road and Bridge	--	5,153
Law Library	--	7,024
Narcotics Task Force	--	2,536
Records Management	38,432	--
Courthouse Security	386,934	--
Total Non Major Funds	445,366	24,441
Totals	\$3,264,676	\$3,264,676

The transfer from the General Fund to the Unit Road Fund and the Grant Fund were made to provide funding for those funds. The transfer to the Courthouse Security Fund was to provide additional funds for security in the new Justice Center. The transfer from the Grant Fund to the Unit Road Fund was made to match the grant revenue with the expenditures.

CALDWELL COUNTY, TEXAS
NOTES TO THE FINANCIAL STATEMENTS
YEAR ENDED SEPTEMBER 30, 2018

F. Long-term debt

The County issues general obligation bonds, certificates of obligation bonds, notes payable and capital lease obligations to provide funds for the acquisition and construction of major capital facilities. These issues are direct obligations and pledge the full faith and credit of the County.

General Debt Currently Outstanding:

Purpose	Original Amount	Year of Issue	Final Maturity	Interest Rate	Balance 9/30/18
General Long-Term Debt Issues					
General Obligation Bonds:					
Certificates of Obligation, 2007	\$5,605,000	8/16/07	2/1/27	4.34%	\$3,165,000
Certificates of Obligation, 2010	1,200,000	12/15/10	8/01/29	3.0% - 4.0%	785,000
Limited tax refund bonds, 2014	8,555,000	3/24/14	2/01/32	2.0% - 3.75%	7,505,000
Comb Ltd Pldg Rev CO's, 2018	5,955,000	93/05/18	2/01/38	3.0% - 4.0%	5,955,000
Total General Long-Term Debt					\$17,410,000

Annual debt service requirements to maturity for general debt:

Year	General Obligation Bonds		Total
	Principal	Interest	
2019	\$840,000	\$562,172	\$1,402,172
2020	865,000	555,808	1,420,808
2021	890,000	529,145	1,419,145
2022	925,000	500,774	1,425,774
2023	1,020,000	468,934	1,488,934
2024-2028	5,475,000	1,753,910	7,228,910
2029-2033	4,795,000	793,004	5,588,004
2034-2038	2,600,000	216,775	2,816,775
Total	\$17,410,000	\$5,380,522	\$22,790,522

CALDWELL COUNTY, TEXAS
NOTES TO THE FINANCIAL STATEMENTS
YEAR ENDED SEPTEMBER 30, 2018

CHANGES IN LONG-TERM LIABILITIES

Long-term liability activity for the year ended September 30, 2018, was as follows:

	Balance 09/30/17	Additions	Retirements	Balance 09/30/18	Due Within One Year
Governmental activities:					
Certificates of obligation	\$4,325,000	--	(\$375,000)	\$3,950,000	\$390,000
Combo Ltd Pldg Rev certificates of	--	5,955,000	--	5,955,000	--
Tax notes	7,945,000	--	(440,000)	7,505,000	450,000
Bond premium	3,154	132,606	(3,535)	132,225	6,850
	<u>12,273,154</u>	<u>6,087,606</u>	<u>(818,535)</u>	<u>17,542,225</u>	<u>846,850</u>
Compensated absences	449,433	107,645	(112,358)	444,720	111,180
Net pension (asset) liability	61,201	2,559,019	(3,322,630)	(702,410)	--
Governmental activity Long-Term	<u>\$12,783,78</u>	<u>\$8,754,270</u>	<u>(\$4,253,523)</u>	<u>\$17,284,53</u>	<u>\$958,030</u>

For the governmental activities, claims and judgements and compensated absences are generally liquidated by the general fund.

Authorized and Unissued Debt

The County had no authorized but unissued debt at 9/30/18.

III. OTHER INFORMATION

A. Risk management

The County is exposed to various risks of loss related to torts; theft of, damage to, and destruction of assets; business interruption; errors and omissions; injuries to employees; employee health benefits; and other claims of various nature. The County participates in the Texas Association of Counties Intergovernmental Risk Pool (Pool) which provides protection for risks of loss. Premiums are paid to the Pool which retains the risk of loss beyond the County's policy deductibles. Any losses reported but unsettled or incurred and not reported, are believed to be insignificant to the County's basic financial statements. For the last three years, there have been no significant reductions of insurance coverage or insurance settlements in excess of insurance coverage.

B. Contingent Liabilities and Commitments

Amounts received or receivable from grantor agencies are subject to audit and adjustment by such agencies. Any disallowed claims, including amounts already collected may constitute a liability of the applicable funds. The amounts, if any, of expenditures which may be disallowed by the grantor cannot be determined at this time although the County expects such amounts, if any, to be immaterial.

The County, periodically, is defendant in various lawsuits. As of September 30, 2018, after consultation with the County's attorney, the County is not aware of any pending or threatened litigation which would have a material effect on the financial statements.

The District Clerk has invested trust funds at various financial institutions in accordance with court orders. The County has a fiduciary responsibility over these funds until their final disposition.

CALDWELL COUNTY, TEXAS
NOTES TO THE FINANCIAL STATEMENTS
YEAR ENDED SEPTEMBER 30, 2018

C. Commitment for Economic Development

The County entered into an agreement with a glass manufacturer, under the Chapter 381 Economic Development Program as of April 14, 2014. Under terms of the agreement, the manufacturer was to build a manufacturing plant and to provide employment for a certain number of employees at an agreed upon level of compensation over a six year period. Based upon compliance with the agreement, the County has committed to make a payment to the manufacturer based upon ad valorem taxes.

For the year ended September 30, 2018, the County paid this manufacturer \$21,380, which represented seventy-five percent of the ad valorem tax paid by the company to the County. The County is committed to pay up to 75% for year 5 and 100% for year 6, which is approximately \$50,000 as of September 30, 2018.

D. Retirement Commitments

1. Plan Description

The County provides retirement, disability, and death benefits for all of its full-time employees through a nontraditional defined benefit plan in the state-wide Texas County and District Retirement System (TCDRS). The Board of Trustees of TCDRS is responsible for the administration of the statewide agent multi-employer public employee retirement system consisting of nontraditional defined benefit pension plans. TCDRS in the aggregate issues a comprehensive annual financial report (CAFR) on a calendar year basis. The CAFR is available upon written request from the TCDRS Board of Trustees at P.O. Box 2034, Austin, Texas, 78768-20343.

The plan provisions are adopted by the County commissioners' court, within the options available in the state statutes governing TCDRS (TCDRS Act). Members can retire at ages 60 and above with 8 or more years of service or with 30 years regardless of age or when the sum of their age and years of service equals 75 or more. Members are vested after 8 years but must leave their accumulated contributions in the plan to receive any employer-financed benefit. Members who withdraw their personal contributions in a lump-sum are not entitled to any amounts contributed by their employer.

Benefit amounts are determined by the sum of the employee's contributions to the plan, with interest, and employer-financed monetary credits. The level of these monetary credits is adopted by the County commissioners' court within the constraints imposed by the TCDRS Act so that the resulting benefits can be expected to be adequately financed by the employer's commitment to contribute. At retirement, death, or disability, the benefit is calculated by converting the sum of the employee's accumulated contribution and the employer-financed monetary credits to a monthly annuity using annuity purchase rates prescribed by the TCDRS Act.

2. Benefits

TCDRS provides retirement, disability, and death benefits. Benefit provisions are adopted by the governing body of the County, within the options available in the state statutes governing TCDRS.

At the December 31, 2017 valuation and measurement date, the following employees were covered by the benefit terms:

Inactive employees (or their beneficiaries) currently receiving benefits	112
Inactive employees entitled to but not yet receiving benefits	253
Active employees	240
	<u>605</u>

3. Contributions

The contribution rates for employees in TCDRS is 5% of employee gross earnings, and the County percentages is 4.0%, both as adopted by the governing body of the County. Under the state law governing TCDRS, the contribution rate for each County is determined annually by the actuary, using the Entry Age

CALDWELL COUNTY, TEXAS
NOTES TO THE FINANCIAL STATEMENTS
YEAR ENDED SEPTEMBER 30, 2018

Normal (EAN) actuarial cost method. The actuarially determined rate is the estimated amount necessary to finance the cost of benefits earned by employees during the year, with an additional amount to finance any unfunded accrued liability.

The County's contributions to TCDRS for the year ended September 30, 2018, were \$411,418 and were equal to the required contributions.

4. Net Pension Liability

The County's Net Pension Asset (NPL) was measured as of December 31, 2017, and the Total Pension Liability (TPL) used to calculate the Net Pension Asset was determined by an actuarial valuation as of that date.

Actuarial assumptions:

The Total Pension Liability in the December 31, 2017 actuarial valuation was determined using the following actuarial assumptions:

The annual salary increase rates assumed for individual members vary by length of service and by entry-age group. The annual rates consist of a general wage inflation component of 3.5% (made up of 3.0% inflation and 0.5% productivity increase assumptions) and a merit, promotion and longevity component that on average approximates 1.4% per year for a career employee.

Actuarial assumptions used in the December 31, 2017, valuation were based on the results of actuarial experience studies. These assumptions were first used in the December 31, 2017 valuation, along with a change to the Entry Age Normal (EAN) actuarial cost method. Assumptions are reviewed annually. No additional changes were made for the 2017 valuation.

The long-term expected rate of return on pension plan investments is 8.10%. The pension plan's policy in regard to the allocation of invested assets is established and may be amended by the TCDRS Board of Trustees. Plan assets are managed on a total return basis with an emphasis on both capital appreciation as well as the production of income, in order to satisfy the short-term and long-term funding needs of TCDRS.

The long-term expected rate of return on pension plan investments was determined using a building-block method in which best estimate ranges of expected future real rates of return (expected returns, net of pension plan investment expense and inflation) are developed for each major asset class. These ranges are combined to produce the long-term expected rate of return by weighting the expected future real rates of return by the target asset allocation percentage and by adding expected inflation. The target allocation and best estimates of arithmetic real rates of return for each major asset class are summarized in the following table:

CALDWELL COUNTY, TEXAS
NOTES TO THE FINANCIAL STATEMENTS
YEAR ENDED SEPTEMBER 30, 2018

Asset Class	Target Allocation	Geometric Real Rate of Return (Expected minus Inflation)
US Equities	11.50%	4.55%
Private Equity	16.00%	7.55%
Global Equities	1.50%	4.85%
International Equities - Developed	11.00%	4.55%
International Equities - Emerging	8.00%	5.55%
Investment - Grade Bonds	3.00%	0.75%
Strategic Credit	8.00%	4.12%
Direct Lending	10.00%	8.06%
Distressed Debt	2.00%	6.30%
REIT Equities	2.00%	4.05%
Master Limited Partnerships (MLPs)	3.00%	6.00%
Private Real Estate Partnerships	6.00%	6.25%
Hedge Funds	18.00%	4.10%
	100.00%	

Discount Rate

The discount rate used to measure the Total Pension Liability (Asset) was 8.1%. The projection of cash flows used to determine the discount rate assumed that employee and employer contributions will be made at the rates specified in statute. Based on that assumption, the pension plan's Fiduciary Net Position was projected to be available to make all projected future benefit payments of current active and inactive employees. Therefore, the long-term expected rate of return on pension plan investments was applied to all periods of projected benefit payments to determine the Total Pension Liability (Asset).

CALDWELL COUNTY, TEXAS
NOTES TO THE FINANCIAL STATEMENTS
YEAR ENDED SEPTEMBER 30, 2018

Changes in the net pension liability

	Increase (Decrease)		
	Total Pension Liability	Plan Fiduciary Net Position	Net Pension Liability(Asset)
	[a]	[b]	[a] - (b)
Balance at 12/31/16	\$17,195,066	\$17,133,864	\$61,202
Changes for the year:			
Service cost	709,330	0	709,330
Interest on total pension liability	1,422,180	0	1,422,180
Effect of plan changes	316,503	0	316,503
Effect of economic/demographic gains or losses	20,818	0	20,818
Effect of of assumptions changes or inputs	77,063	0	77,063
Refund of contributions	(96,493)	(96,493)	0
Benefit payments	(610,497)	(610,497)	0
Administrative expenses	0	(13,125)	13,125
Member contributions	0	457,059	(457,059)
Net investment income	0	2,502,740	(2,502,740)
Employer contributions	0	361,461	(361,461)
Other	0	1,371	(1,371)
Net changes	1,838,904	2,602,516	(763,612)
Balance at 12/31/16	<u>\$19,033,970</u>	<u>\$19,736,380</u>	<u>(\$702,410)</u>

Sensitivity of the net pension liability to changes in the discount rate

The following presents the net pension liability of the County, calculated using the discount rate of 8.1%, as well as what the County's net pension liability would be if it were calculated using a discount rate that is 1 percentage point lower (7.1%) or 1 percentage point higher (9.1%) than the current rate:

	1% Decrease 7.1%	Current Discount Rate 8.1%	1% Increase 9.1%
Total pension liability	\$21,715,097	\$19,033,970	\$16,811,108
Fiduciary net position	19,736,379	19,736,380	19,736,379
Net Pension Liability (Asset)	<u>\$1,978,718</u>	<u>(\$702,410)</u>	<u>(\$2,925,271)</u>

Pension Plan Fiduciary Net Position

Detailed information about the pension plan's Fiduciary Net Position is available in a separately-issued TCDRS financial report. That report may be obtained on the Internet at www.tcdrs.org.

CALDWELL COUNTY, TEXAS
NOTES TO THE FINANCIAL STATEMENTS
YEAR ENDED SEPTEMBER 30, 2018

Pension Expense and Deferred Outflows and Inflows of Resources Related to Pensions

For the year ended September 30, 2018, the County recognized pension expense of \$700,271. At September 30, 2018, the County reported deferred outflows and inflows of resources related to pensions from the following sources:

	Original Amount	Date Established	Original Recognition Period	Amount Recognized in 9/30/18 Expense	Balance of Deferred Inflows 12/31/17	Balance of Deferred Outflows 12/31/2017
Investment (gains) or losses	(\$1,110,935)	12/31/2017	5.0	(\$222,187)	\$888,748	\$ --
	113,734	12/31/2016	5.0	22,747	--	68,240
	1,386,998	12/31/2015	5.0	277,400	--	554,799
	211,931	12/31/2014	5.0	42,386	--	42,386
Economic/demographic gains or losses	20,818	12/31/2017	4.0	5,205	--	15,614
	(173,840)	12/31/2016	4.0	(43,460)	86,920	--
	(234,308)	12/31/2015	4.0	(58,577)	58,577	--
	14,581	12/31/2014	4.0	3,645	--	--
Assumption changes or inputs	77,063	12/31/2017	4.0	19,266	--	57,797
	--	12/31/2016	4.0	--	--	--
	171,772	12/31/2015	4.0	42,943	--	42,943
	--	12/31/2014	4.0	--	--	--
Employer contributions made subsequent to measurement date				--	--	313,574
				<u>\$89,368</u>	<u>\$1,034,245</u>	<u>\$1,095,353</u>

\$262,887 reported as deferred outflows of resources related to pensions resulting from contributions subsequent to the measurement date will be recognized as a reduction of the net pension liability for the year ending September 30, 2019. Other amounts reported as deferred outflows and inflows of resources related to pensions will be recognized in pension expense as follows:

Deferred Inflows/outflows to Be Recognized in Future Years

Year ended December 31,	
2018	\$85,722
2019	58,969
2020	(174,970)
2021	(222,187)
2022	--
	<u><u>(\$252,466)</u></u>

CALDWELL COUNTY, TEXAS
NOTES TO THE FINANCIAL STATEMENTS
YEAR ENDED SEPTEMBER 30, 2018

E. Concentrations of Credit Risk

Taxes receivable are due from citizens and businesses within the County's boundaries. Risk of loss is immaterial due to wide dispersion of receivables and because of policies which address procedures for filing property tax liens. Fines receivable are due from citizens primarily within the County's boundaries. Risk of loss is reduced by an allowance for uncollectibles and collection policies.

This page is left blank intentionally.

Required Supplementary Information

Required supplementary information includes financial information and disclosures required by the Governmental Accounting Standards Board but not considered a part of the basic financial statements.

CALDWELL COUNTY, TEXAS
GENERAL FUND
BUDGETARY COMPARISON SCHEDULE
FOR THE YEAR ENDED SEPTEMBER 30, 2018

EXHIBIT B-1

	Budgeted Amounts		Actual	Variance with Final Budget Positive (Negative)
	Original	Final		
Revenue:				
<i>Taxes</i>	\$ 16,782,511	\$ 16,782,511	\$ 16,903,493	\$ 120,982
<i>Licenses and permits</i>	756,000	756,000	596,066	(159,934)
<i>Intergovernmental</i>	1,143,692	1,272,594	1,347,255	74,661
<i>Fees of office</i>	835,250	835,250	992,867	157,617
<i>Fines</i>	757,000	757,000	931,435	174,435
<i>Miscellaneous</i>	105,000	200,419	109,354	(91,065)
<i>Investment earnings</i>	10,000	10,000	227,814	217,814
Total revenues	<u>20,389,453</u>	<u>20,613,774</u>	<u>21,108,284</u>	<u>494,510</u>
Expenditures:				
Current:				
<i>General administration</i>	2,865,289	2,875,699	2,465,447	410,252
<i>Judicial</i>	2,002,010	1,999,993	1,815,669	184,324
<i>Legal</i>	965,198	965,198	925,328	39,870
<i>Financial administration</i>	1,384,780	1,384,780	1,328,677	56,103
<i>Public facilities</i>	671,256	676,895	540,975	135,920
<i>Public safety</i>	8,086,823	8,141,447	7,449,362	692,085
<i>Environmental protection</i>	80,825	80,825	64,889	15,936
<i>Health and welfare</i>	808,281	808,281	684,721	123,560
<i>Conservation - agriculture</i>	108,335	108,335	105,875	2,460
Total Expenditures	<u>16,972,797</u>	<u>17,041,453</u>	<u>15,380,943</u>	<u>1,660,510</u>
Excess (Deficiency) of Revenues Over (Under) Expenditures	<u>3,416,656</u>	<u>3,572,321</u>	<u>5,727,341</u>	<u>2,155,020</u>
Other Financing Sources (Uses):				
<i>Transfers in</i>	7,024	7,024	24,441	17,417
<i>Transfers out</i>	(3,240,235)	(3,242,252)	(3,240,235)	2,017
<i>Insurance proceeds</i>	--	42,481	90,397	47,916
<i>Sale of capital assets</i>	28,000	28,000	44,340	16,340
Total Other Financing Sources (Uses)	<u>(3,205,211)</u>	<u>(3,164,747)</u>	<u>(3,081,057)</u>	<u>83,690</u>
Net Change in Fund Balances	211,445	407,574	2,646,284	2,238,710
Fund Balances - Beginning	8,015,090	8,015,090	8,015,090	--
Fund Balances - Ending	<u>\$ 8,226,535</u>	<u>\$ 8,422,664</u>	<u>\$ 10,661,374</u>	<u>\$ 2,238,710</u>

CALDWELL COUNTY, TEXAS
UNIT ROAD FUND
BUDGETARY COMPARISON SCHEDULE
FOR THE YEAR ENDED SEPTEMBER 30, 2018

EXHIBIT B-2

	Budgeted Amounts		Actual	Variance with Final Budget Positive (Negative)
	Original	Final		
Revenue:				
<i>Taxes</i>	\$ 322,349	\$ 322,349	\$ 366,830	\$ 44,481
<i>Licenses and permits</i>	64,400	64,400	42,079	(22,321)
<i>Intergovernmental</i>	23,000	23,000	565,193	542,193
<i>Miscellaneous</i>	3,000	3,000	21,907	18,907
Total revenues	<u>412,749</u>	<u>412,749</u>	<u>996,009</u>	<u>583,260</u>
Expenditures:				
Current:				
<i>Public transportation</i>	3,207,618	3,515,465	3,406,597	108,868
Total Expenditures	<u>3,207,618</u>	<u>3,515,465</u>	<u>3,406,597</u>	<u>108,868</u>
Excess (Deficiency) of Revenues Over (Under) Expenditures	<u>(2,794,869)</u>	<u>(3,102,716)</u>	<u>(2,410,588)</u>	<u>692,128</u>
Other Financing Sources (Uses):				
<i>Transfers in</i>	2,794,869	2,794,869	2,794,869	--
Total Other Financing Sources (Uses)	<u>2,794,869</u>	<u>2,794,869</u>	<u>2,794,869</u>	<u>--</u>
Net Change in Fund Balances	--	(307,847)	384,281	692,128
Fund Balances - Beginning	1,250,729	1,250,729	1,250,729	--
Fund Balances - Ending	<u>\$ 1,250,729</u>	<u>\$ 942,882</u>	<u>\$ 1,635,010</u>	<u>\$ 692,128</u>

CALDWELL COUNTY, TEXAS
**SCHEDULE OF CHANGES IN THE COUNTY'S
NET PENSION LIABILITY (ASSET) AND RELATED RATIOS
CALDWELL COUNTY PENSION PLAN
LAST TEN CALENDAR YEARS**

	December 31,									
	2017	2016	2015	2014	2013	2012	2011	2010	2009	2008
Total pension liability:										
Service cost	\$ 709,330	\$ 735,926	\$ 699,158	\$ 661,894	\$ --	\$ --	\$ --	\$ --	\$ --	\$ --
Interest	1,422,180	1,295,217	1,204,758	1,104,107	--	--	--	--	--	--
Changes of benefit terms	316,503	--	(123,589)	--	--	--	--	--	--	--
Differences between expected and actual experience	20,818	(173,840)	(234,308)	14,581	--	--	--	--	--	--
Changes of assumptions	77,063	--	171,772	--	--	--	--	--	--	--
Benefit payments, including refunds of employee contributions	(706,990)	(572,411)	(617,525)	(543,659)	--	--	--	--	--	--
Net change in total pension liability	1,838,904	1,284,892	1,100,266	1,236,923	--	--	--	--	--	--
Total pension liability - beginning	17,195,066	15,910,174	14,809,908	13,572,985	--	--	--	--	--	--
Total pension liability - ending (a)	<u>\$ 19,033,970</u>	<u>\$ 17,195,066</u>	<u>\$ 15,910,174</u>	<u>\$ 14,809,908</u>	<u>\$ --</u>	<u>\$ --</u>	<u>\$ --</u>	<u>\$ --</u>	<u>\$ --</u>	<u>\$ --</u>
Plan fiduciary net position:										
Contributions - employer	\$ 361,461	\$ 337,091	\$ 333,197	\$ 326,662	\$ --	\$ --	\$ --	\$ --	\$ --	\$ --
Contributions - employee	457,059	421,365	416,496	408,329	--	--	--	--	--	--
Net investment income	2,502,740	1,174,886	(90,925)	990,419	--	--	--	--	--	--
Benefit payments, including refunds of employee contributions	(706,990)	(572,411)	(617,525)	(543,659)	--	--	--	--	--	--
Administrative expense	(13,125)	(12,768)	(11,390)	(11,711)	--	--	--	--	--	--
Other	1,371	(75,001)	58,418	(17,254)	--	--	--	--	--	--
Net change in plan fiduciary net position	2,602,516	1,273,162	88,271	1,152,786	--	--	--	--	--	--
Plan fiduciary net position - beginning	17,133,864	15,860,702	15,772,431	14,619,645	--	--	--	--	--	--
Plan fiduciary net position - ending (b)	<u>\$ 19,736,380</u>	<u>\$ 17,133,864</u>	<u>\$ 15,860,702</u>	<u>\$ 15,772,431</u>	<u>\$ --</u>	<u>\$ --</u>	<u>\$ --</u>	<u>\$ --</u>	<u>\$ --</u>	<u>\$ --</u>
County's net pension liability (asset) - ending (a) - (b)	<u>\$ (702,410)</u>	<u>\$ 61,202</u>	<u>\$ 49,472</u>	<u>\$ (962,523)</u>	<u>\$ --</u>	<u>\$ --</u>	<u>\$ --</u>	<u>\$ --</u>	<u>\$ --</u>	<u>\$ --</u>
Plan fiduciary net position as a percentage of the total pension asset	103.69%	99.64%	99.69%	106.50%	--	--	--	--	--	--
Covered-employee payroll	\$ 9,036,531	\$ 8,427,292	\$ 8,329,910	\$ 8,166,575	\$ --	\$ --	\$ --	\$ --	\$ --	\$ --
County's net pension liability (asset) as a percentage of covered-employee payroll	-7.77%	0.73%	0.59%	-11.79%	--	--	--	--	--	--

Notes to Schedule:

* This schedule is presented to illustrate the requirement to show information for 10 years. However, until a full 10-year trend is compiled, this schedule provides the information only for those years for which information is available.

CALDWELL COUNTY, TEXAS
SCHEDULE OF COUNTY CONTRIBUTIONS
CALDWELL COUNTY PENSION PLAN
LAST TEN FISCAL YEARS

	Fiscal Year									
	2018	2017	2016	2015	2014	2013	2012	2011	2010	2009
Actuarially determined contribution	\$ 411,418	\$ 353,533	\$ 337,091	\$ 326,662	\$ 358,350	\$ 315,796	\$ 268,818	\$ 258,547	\$ 203,705	\$ 188,863
Contributions in relation to the actuarially determined contribution	(411,418)	(353,533)	(337,091)	(326,662)	(358,350)	(1,055,796)	(268,818)	(258,547)	(203,705)	(188,863)
Contribution deficiency (excess)	\$ --	\$ --	\$ --	\$ --	\$ --	\$ (740,000)	\$ --	\$ --	\$ --	\$ --
Covered-employee payroll	\$ 9,510,392	\$ 8,835,056	\$ 8,292,576	\$ 8,301,131	\$ 7,673,455	\$ 7,112,512	\$ 6,370,094	\$ 6,126,705	\$ 5,820,145	\$ 5,305,128
Contributions as a percentage of covered-employee payroll	4.33%	4.00%	4.06%	3.94%	4.67%	4.44%	4.22%	4.22%	3.50%	3.56%
Valuation date:	12/31/17									

Actuarially determined contribution rates are calculated as of December 31, two years prior to the end of the fiscal year in which contributions are reported.

Methods and assumptions used to determine contribution rates:

Actuarial cost method	Entry age normal
Amortization method	Level percentage of payroll, closed
Remaining amortization period	12.4 years
Asset valuation method	5-year smoothed market
Inflation	2.75%
Salary increases	Varies by age and service. 4.9% average over career.
Investment rate of return	8.00%, net of pension plan investment expense, including inflation
Retirement age	Members who are eligible for service retirement are assumed to commence receiving benefit payments based on age. The average at retirement is 61.
Turnover	New employees are assumed to replace any terminated members and have similar entry ages.
Mortality	In the 2015 actuarial valuation, assumed life expectancies were adjusted as a result of adopting a projecting scale (100% of the MP 2014 Ultimate Scale) for 2014 and later. Previously Scale AA had been used. The base table is the RP-2000 table projected with Scale AA to 2014.
Changes in assumptions and methods Reflected in the Schedule of Employer Contributions	2015: New inflation, mortality and other assumptions were reflected; 2017: New mortality assumptions were reflected.
Changes in Plan Provisions Reflected in the Schedule of Employer Contributions	2015 and 2016: No changes in plan provisions; 2017: New annuity purchase rates were reflected for benefits earned.

CALDWELL COUNTY, TEXAS
NOTES TO REQUIRED SUPPLEMENTARY INFORMATION
Year Ended September 30, 2018

STEWARDSHIP, COMPLIANCE, AND ACCOUNTABILITY

A. Budgetary Information

Annual budgets are adopted on the GAAP basis of accounting for the general fund, certain special revenue funds, and the debt service fund. All annual appropriations lapse at fiscal year end.

The County Judge is, by statute, the Budget Officer of the County and has the responsibility of preparing the County's budget. Under the County's budgeting procedures, each department submits a budget request to the County Judge. The County Judge reviews budget requests and holds informal hearings when needed. Before October 1, a proposed budget is presented to the Commissioners' Court. A public hearing is then held and the Commissioners' Court takes action on the proposed budget. Before determining the final budget, the Commissioners' Court may increase or decrease the amounts requested by the various departments. Amounts finally budgeted may not exceed the estimate of revenues and available fund balance.

Once the budget has been adopted by the Commissioners' Court, the County Auditor is responsible for monitoring the expenditures of the various departments of the County to prevent expenditures from exceeding budgeted appropriations and for keeping members of the Commissioners' Court advised of the conditions of the various funds and accounts.

The appropriated budget is prepared by fund. Any transfers of appropriations are first approved by the Commissioners' Court. Thus, the legal level of budgetary control is at the fund level. Several supplemental appropriations were required during the year.

B. The following funds had deficit fund balances at September 30, 2018:

Special Revenue Funds:	
Grant Fund	\$356,183
Law Library	52,316

C. The following funds had expenditures in excess of appropriations at September 30, 2018:

Special Revenue Funds:	
Justice Court Technology	\$1,972
Law Library	312
Hot Check	783
Debt Service	328

*Combining Statements and Budget Comparisons
as Supplementary Information*

This supplementary information includes financial statements and schedules not required by the Governmental Accounting Standards Board, nor a part of the basic financial statements, but are presented for purposes of additional analysis.

CALDWELL COUNTY, TEXAS
COMBINING BALANCE SHEET
NONMAJOR GOVERNMENTAL FUNDS
SEPTEMBER 30, 2018

	Special Revenue Funds	Debt Service Fund	Total Nonmajor Governmental Funds (See Exhibit A-3)
ASSETS			
Assets:			
<i>Cash and cash equivalents</i>	\$ 505,177	\$ 946,915	\$ 1,452,092
<i>Receivables (net of allowances for uncollectibles):</i>			
Taxes	--	161,105	161,105
Intergovernmental	102,890	--	102,890
Total Assets	<u>\$ 608,067</u>	<u>\$ 1,108,020</u>	<u>\$ 1,716,087</u>
LIABILITIES DEFERRED INFLOWS OF RESOURCES, AND FUND BALANCES			
Liabilities:			
<i>Accounts Payable</i>	\$ 1,390	\$ --	\$ 1,390
<i>Due to Other Funds</i>	509,104	--	509,104
Total Liabilities	<u>510,494</u>	<u>--</u>	<u>510,494</u>
Deferred Inflows of Resources			
<i>Deferred tax revenue</i>	--	150,551	150,551
<i>Deferred grant revenue</i>	1,800	--	1,800
Total deferred inflows of resources	<u>1,800</u>	<u>150,551</u>	<u>152,351</u>
Fund Balances:			
<i>Restricted</i>	439,463	957,469	1,396,932
<i>Committed</i>	64,809	--	64,809
<i>Unassigned</i>	(408,499)	--	(408,499)
Total Fund Balance	<u>95,773</u>	<u>957,469</u>	<u>1,053,242</u>
Total Liabilities, Deferred Inflows of Resources, and Fund Balance	<u>\$ 608,067</u>	<u>\$ 1,108,020</u>	<u>\$ 1,716,087</u>

CALDWELL COUNTY, TEXAS

COMBINING STATEMENT OF REVENUES, EXPENDITURES,
AND CHANGES IN FUND BALANCES
NONMAJOR GOVERNMENTAL FUNDS
FOR THE YEAR ENDED SEPTEMBER 30, 2018

	Special Revenue Funds	Debt Service Fund	Total Nonmajor Governmental Funds (See Exhibit A-5)
Revenue:			
<i>Taxes</i>	\$ --	\$ 1,416,605	\$ 1,416,605
<i>Intergovernmental</i>	457,108	--	457,108
<i>Fees of office</i>	271,107	--	271,107
<i>Fines</i>	18,125	--	18,125
<i>Miscellaneous</i>	6,649	--	6,649
<i>Investment earnings</i>	663	15,673	16,336
Total revenues	<u>753,652</u>	<u>1,432,278</u>	<u>2,185,930</u>
Expenditures:			
Current:			
<i>General administration</i>	662,840	--	662,840
<i>Judicial</i>	122,887	--	122,887
<i>Legal</i>	19,140	--	19,140
<i>Public safety</i>	15,940	--	15,940
<i>Public transportation</i>	118,052	--	118,052
Debt Service:			
<i>Principal</i>	--	816,830	816,830
<i>Interest and fiscal charges</i>	--	402,822	402,822
Total Expenditures	<u>938,859</u>	<u>1,219,652</u>	<u>2,158,511</u>
Excess (Deficiency) of Revenues Over (Under) Expenditures	<u>(185,207)</u>	<u>212,626</u>	<u>27,419</u>
Other Financing Sources (Uses):			
<i>Transfers in</i>	445,366	--	445,366
<i>Transfers out</i>	(24,441)	--	(24,441)
Total Other Financing Sources (Uses)	<u>420,925</u>	<u>--</u>	<u>420,925</u>
Net Change in Fund Balances	235,718	212,626	448,344
Fund Balances (Deficits) - Beginning	(139,945)	744,843	604,898
Fund Balances - Ending	<u>\$ 95,773</u>	<u>\$ 957,469</u>	<u>\$ 1,053,242</u>

CALDWELL COUNTY, TEXAS
COMBINING BALANCE SHEET
NONMAJOR SPECIAL REVENUE FUNDS
SEPTEMBER 30, 2018

	Grant	LEOSE Constables Fund	Justice Court Technology	DRC Program
ASSETS				
Assets:				
<i>Cash and cash equivalents</i>	\$ --	\$ 3,361	\$ 16,419	\$ 1,013
<i>Receivables (net of allowances for uncollectibles):</i>				
Intergovernmental	102,890	--	--	--
Total Assets	\$ 102,890	\$ 3,361	\$ 16,419	\$ 1,013
LIABILITIES DEFERRED INFLOWS OF RESOURCES, AND FUND BALANCES				
Liabilities:				
<i>Accounts Payable</i>	\$ 65	\$ --	\$ --	\$ --
<i>Due to Other Funds</i>	457,208	--	--	--
Total Liabilities	457,273	--	--	--
Deferred Inflows of Resources				
<i>Deferred grant revenue</i>	1,800	--	--	--
Total deferred inflows of resources	1,800	--	--	--
Fund Balances:				
<i>Restricted</i>	--	3,361	16,419	1,013
<i>Committed</i>	--	--	--	--
<i>Unassigned</i>	(356,183)	--	--	--
Total Fund Balance (Deficits)	(356,183)	3,361	16,419	1,013
Total Liabilities, Deferred Inflows of Resources, and Fund Balance	\$ 102,890	\$ 3,361	\$ 16,419	\$ 1,013

Records Preservation Fund	Law Library	Sheriff's Forfeiture	Hot Check	DA Forfeiture Fund
\$ 34,487	\$ --	\$ 28,103	\$ 65,125	\$ 39,794
--	--	--	--	--
<u>\$ 34,487</u>	<u>\$ --</u>	<u>\$ 28,103</u>	<u>\$ 65,125</u>	<u>\$ 39,794</u>
\$ 565	\$ 420	\$ --	\$ 316	\$ --
--	51,896	--	--	--
<u>565</u>	<u>52,316</u>	<u>--</u>	<u>316</u>	<u>--</u>
--	--	--	--	--
--	--	--	--	--
33,922	--	28,103	--	39,794
--	--	--	64,809	--
<u>33,922</u>	<u>(52,316)</u>	<u>--</u>	<u>--</u>	<u>--</u>
<u>\$ 34,487</u>	<u>\$ --</u>	<u>\$ 28,103</u>	<u>\$ 65,125</u>	<u>\$ 39,794</u>

CALDWELL COUNTY, TEXAS
COMBINING BALANCE SHEET
NONMAJOR SPECIAL REVENUE FUNDS
SEPTEMBER 30, 2018

	<u>Records Management</u>	<u>Courthouse Security</u>	<u>Total Nonmajor Special Revenue Funds (See Exhibit C-1)</u>
ASSETS			
Assets:			
<i>Cash and cash equivalents</i>	\$ 59,978	\$ 256,897	\$ 505,177
<i>Receivables (net of allowances for uncollectibles):</i>			
Intergovernmental	--	--	102,890
Total Assets	<u>\$ 59,978</u>	<u>\$ 256,897</u>	<u>\$ 608,067</u>
LIABILITIES DEFERRED INFLOWS OF RESOURCES, AND FUND BALANCES			
Liabilities:			
<i>Accounts Payable</i>	\$ 23	\$ 1	\$ 1,390
<i>Due to Other Funds</i>	--	--	509,104
Total Liabilities	<u>23</u>	<u>1</u>	<u>510,494</u>
Deferred Inflows of Resources			
<i>Deferred grant revenue</i>	--	--	1,800
Total deferred inflows of resources	<u>--</u>	<u>--</u>	<u>1,800</u>
Fund Balances:			
<i>Restricted</i>	59,955	256,896	439,463
<i>Committed</i>	--	--	64,809
<i>Unassigned</i>	--	--	(408,499)
Total Fund Balance (Deficits)	<u>59,955</u>	<u>256,896</u>	<u>95,773</u>
Total Liabilities, Deferred Inflows of Resources, and Fund Balance	<u>\$ 59,978</u>	<u>\$ 256,897</u>	<u>\$ 608,067</u>

This page is left blank intentionally.

CALDWELL COUNTY, TEXAS

COMBINING STATEMENT OF REVENUES, EXPENDITURES,
AND CHANGES IN FUND BALANCES
NONMAJOR SPECIAL REVENUE FUNDS
FOR THE YEAR ENDED SEPTEMBER 30, 2018

	Grant	911	Special Road & Bridge	LEOSE Constables Fund
Revenue:				
<i>Intergovernmental</i>	\$ 451,465	\$ --	\$ --	\$ 5,643
<i>Fees of office</i>	--	--	--	--
<i>Fines</i>	--	--	--	--
<i>Miscellaneous</i>	--	--	--	--
<i>Investment earnings</i>	--	--	--	--
Total revenues	<u>451,465</u>	<u>--</u>	<u>--</u>	<u>5,643</u>
Expenditures:				
Current:				
<i>General administration</i>	131,551	--	--	--
<i>Judicial</i>	56,739	--	--	--
<i>Legal</i>	--	--	--	--
<i>Public safety</i>	652	--	--	2,282
<i>Public transportation</i>	118,052	--	--	--
Total Expenditures	<u>306,994</u>	<u>--</u>	<u>--</u>	<u>2,282</u>
Excess (Deficiency) of Revenues Over (Under) Expenditures	<u>144,471</u>	<u>--</u>	<u>--</u>	<u>3,361</u>
Other Financing Sources (Uses):				
<i>Transfers in</i>	20,000	--	--	--
<i>Transfers out</i>	--	(9,728)	(5,153)	--
Total Other Financing Sources (Uses)	<u>20,000</u>	<u>(9,728)</u>	<u>(5,153)</u>	<u>--</u>
Net Change in Fund Balances	164,471	(9,728)	(5,153)	3,361
Fund Balances (Deficits) - Beginning	(520,654)	9,728	5,153	--
Fund Balances (Deficits) - Ending	<u>\$ (356,183)</u>	<u>\$ --</u>	<u>\$ --</u>	<u>\$ 3,361</u>

Justice Court Technology	DRC Program	Records Preservation Fund	Law Library	Sheriff's Forfeiture
\$ --	\$ --	\$ --	\$ --	\$ --
30,236	(2,806)	164,090	15,789	--
--	--	--	--	7,231
--	--	--	--	--
--	--	--	--	235
<u>30,236</u>	<u>(2,806)</u>	<u>164,090</u>	<u>15,789</u>	<u>7,466</u>
--	--	155,950	4,788	--
34,496	--	--	--	--
--	--	--	--	--
--	--	--	--	13,006
--	--	--	--	--
<u>34,496</u>	<u>--</u>	<u>155,950</u>	<u>4,788</u>	<u>13,006</u>
<u>(4,260)</u>	<u>(2,806)</u>	<u>8,140</u>	<u>11,001</u>	<u>(5,540)</u>
--	--	--	--	--
--	--	--	(7,024)	--
--	--	--	<u>(7,024)</u>	--
(4,260)	(2,806)	8,140	3,977	(5,540)
20,679	3,819	25,782	(56,293)	33,643
<u>\$ 16,419</u>	<u>\$ 1,013</u>	<u>\$ 33,922</u>	<u>\$ (52,316)</u>	<u>\$ 28,103</u>

CALDWELL COUNTY, TEXAS
COMBINING STATEMENT OF REVENUES, EXPENDITURES,
AND CHANGES IN FUND BALANCES
NONMAJOR SPECIAL REVENUE FUNDS
FOR THE YEAR ENDED SEPTEMBER 30, 2018

	<u>Hot Check</u>	<u>DA Forfeiture Fund</u>
Revenue:		
<i>Intergovernmental</i>	\$ --	\$ --
<i>Fees of office</i>	8,280	--
<i>Fines</i>	--	10,894
<i>Miscellaneous</i>	521	--
<i>Investment earnings</i>	--	410
Total revenues	<u>8,801</u>	<u>11,304</u>
Expenditures:		
Current:		
<i>General administration</i>	8,183	--
<i>Judicial</i>	--	--
<i>Legal</i>	--	19,140
<i>Public safety</i>	--	--
<i>Public transportation</i>	--	--
Total Expenditures	<u>8,183</u>	<u>19,140</u>
Excess (Deficiency) of Revenues Over (Under) Expenditures	<u>618</u>	<u>(7,836)</u>
Other Financing Sources (Uses):		
<i>Transfers in</i>	--	--
<i>Transfers out</i>	--	--
Total Other Financing Sources (Uses)	<u>--</u>	<u>--</u>
Net Change in Fund Balances	618	(7,836)
Fund Balances (Deficits) - Beginning	64,191	47,630
Fund Balances (Deficits) - Ending	<u>\$ 64,809</u>	<u>\$ 39,794</u>

Narcotics Task Force	Records Management	Courthouse Security	Total Nonmajor Special Revenue Funds (See Exhibit C-2)
\$ --	\$ --	\$ --	\$ 457,108
--	14,926	40,592	271,107
--	--	--	18,125
6,128	--	--	6,649
18	--	--	663
<u>6,146</u>	<u>14,926</u>	<u>40,592</u>	<u>753,652</u>
--	1,077	361,291	662,840
--	31,652	--	122,887
--	--	--	19,140
--	--	--	15,940
--	--	--	118,052
<u>--</u>	<u>32,729</u>	<u>361,291</u>	<u>938,859</u>
<u>6,146</u>	<u>(17,803)</u>	<u>(320,699)</u>	<u>(185,207)</u>
--	38,432	386,934	445,366
(2,536)	--	--	(24,441)
<u>(2,536)</u>	<u>38,432</u>	<u>386,934</u>	<u>420,925</u>
3,610	20,629	66,235	235,718
(3,610)	39,326	190,661	(139,945)
<u>\$ --</u>	<u>\$ 59,955</u>	<u>\$ 256,896</u>	<u>\$ 95,773</u>

CALDWELL COUNTY, TEXAS
GRANT FUND
SPECIAL REVENUE FUND
BUDGETARY COMPARISON SCHEDULE
FOR THE YEAR ENDED SEPTEMBER 30, 2018

EXHIBIT C-5

	<u>Budget</u>	<u>Actual</u>	Variance Positive (Negative)
Revenue:			
<i>Intergovernmental</i>	\$ 1,100,000	\$ 451,465	\$ (648,535)
Total revenues	<u>1,100,000</u>	<u>451,465</u>	<u>(648,535)</u>
Expenditures:			
Current:			
<i>General administration</i>	--	131,551	(131,551)
<i>Judicial</i>	120,000	56,739	63,261
<i>Public safety</i>	--	652	(652)
<i>Public transportation</i>	1,000,000	118,052	881,948
Total Expenditures	<u>1,120,000</u>	<u>306,994</u>	<u>813,006</u>
Excess (Deficiency) of Revenues Over (Under) Expenditures	<u>(20,000)</u>	<u>144,471</u>	<u>164,471</u>
Other Financing Sources (Uses):			
<i>Transfers in</i>	20,000	20,000	--
Total Other Financing Sources (Uses)	<u>20,000</u>	<u>20,000</u>	<u>--</u>
Net Change in Fund Balances	--	164,471	164,471
Fund Balances (Deficits) - Beginning	(520,654)	(520,654)	--
Fund Balances (Deficits) - Ending	<u>\$ (520,654)</u>	<u>\$ (356,183)</u>	<u>\$ 164,471</u>

CALDWELL COUNTY, TEXAS
JUSTICE COURT TECHNOLOGY
SPECIAL REVENUE FUND
BUDGETARY COMPARISON SCHEDULE
FOR THE YEAR ENDED SEPTEMBER 30, 2018

EXHIBIT C-6

	<u>Budget</u>	<u>Actual</u>	Variance Positive (Negative)
Revenue:			
<i>Fees of office</i>	\$ 19,400	\$ 30,236	\$ 10,836
Total revenues	<u>19,400</u>	<u>30,236</u>	<u>10,836</u>
Expenditures:			
Current:			
<i>Judicial</i>	<u>32,524</u>	<u>34,496</u>	<u>(1,972)</u>
Total Expenditures	<u>32,524</u>	<u>34,496</u>	<u>(1,972)</u>
Net Change in Fund Balances	(13,124)	(4,260)	8,864
Fund Balances - Beginning	20,679	20,679	--
Fund Balances - Ending	<u>\$ 7,555</u>	<u>\$ 16,419</u>	<u>\$ 8,864</u>

CALDWELL COUNTY, TEXAS
RECORDS PRESERVATION FUND
SPECIAL REVENUE FUND
BUDGETARY COMPARISON SCHEDULE
FOR THE YEAR ENDED SEPTEMBER 30, 2018

EXHIBIT C-7

	<u>Budget</u>	<u>Actual</u>	Variance Positive (Negative)
Revenue:			
<i>Fees of office</i>	\$ 148,000	\$ 164,090	\$ 16,090
Total revenues	<u>148,000</u>	<u>164,090</u>	<u>16,090</u>
Expenditures:			
Current:			
<i>General administration</i>	169,777	155,950	13,827
Total Expenditures	<u>169,777</u>	<u>155,950</u>	<u>13,827</u>
Net Change in Fund Balances	(21,777)	8,140	29,917
Fund Balances - Beginning	25,782	25,782	--
Fund Balances - Ending	<u>\$ 4,005</u>	<u>\$ 33,922</u>	<u>\$ 29,917</u>

CALDWELL COUNTY, TEXAS
LAW LIBRARY
SPECIAL REVENUE FUND
BUDGETARY COMPARISON SCHEDULE
FOR THE YEAR ENDED SEPTEMBER 30, 2018

EXHIBIT C-8

	<u>Budget</u>	<u>Actual</u>	<u>Variance Positive (Negative)</u>
Revenue:			
<i>Fees of office</i>	\$ 11,500	\$ 15,789	\$ 4,289
Total revenues	<u>11,500</u>	<u>15,789</u>	<u>4,289</u>
Expenditures:			
Current:			
<i>General administration</i>	4,476	4,788	(312)
Total Expenditures	<u>4,476</u>	<u>4,788</u>	<u>(312)</u>
Excess (Deficiency) of Revenues Over (Under) Expenditures	<u>7,024</u>	<u>11,001</u>	<u>3,977</u>
Other Financing Sources (Uses):			
<i>Transfers out</i>	(7,024)	(7,024)	--
Total Other Financing Sources (Uses)	<u>(7,024)</u>	<u>(7,024)</u>	<u>--</u>
Net Change in Fund Balances	--	3,977	3,977
Fund Balances - Beginning	(56,293)	(56,293)	--
Fund Balances - Ending	<u>\$ (56,293)</u>	<u>\$ (52,316)</u>	<u>\$ 3,977</u>

CALDWELL COUNTY, TEXAS
HOT CHECK
SPECIAL REVENUE FUND
BUDGETARY COMPARISON SCHEDULE
FOR THE YEAR ENDED SEPTEMBER 30, 2018

EXHIBIT C-9

	<u>Budget</u>	<u>Actual</u>	Variance Positive (Negative)
Revenue:			
<i>Fees of office</i>	\$ 4,500	\$ 8,280	\$ 3,780
<i>Miscellaneous</i>	38	521	483
Total revenues	<u>4,538</u>	<u>8,801</u>	<u>4,263</u>
Expenditures:			
Current:			
<i>General administration</i>	7,400	8,183	(783)
Total Expenditures	<u>7,400</u>	<u>8,183</u>	<u>(783)</u>
Net Change in Fund Balances	(2,862)	618	3,480
Fund Balances - Beginning	64,191	64,191	--
Fund Balances - Ending	<u>\$ 61,329</u>	<u>\$ 64,809</u>	<u>\$ 3,480</u>

CALDWELL COUNTY, TEXAS
RECORDS MANAGEMENT
SPECIAL REVENUE FUND
BUDGETARY COMPARISON SCHEDULE
FOR THE YEAR ENDED SEPTEMBER 30, 2018

EXHIBIT C-10

	Budget	Actual	Variance Positive (Negative)
Revenue:			
<i>Fees of office</i>	\$ 16,000	\$ 14,926	\$ (1,074)
Total revenues	<u>16,000</u>	<u>14,926</u>	<u>(1,074)</u>
Expenditures:			
Current:			
<i>General administration</i>	1,000	1,077	(77)
<i>Judicial</i>	56,264	31,652	24,612
Total Expenditures	<u>57,264</u>	<u>32,729</u>	<u>24,535</u>
Excess (Deficiency) of Revenues Over (Under) Expenditures	<u>(41,264)</u>	<u>(17,803)</u>	<u>23,461</u>
Other Financing Sources (Uses):			
<i>Transfers in</i>	36,415	38,432	2,017
Total Other Financing Sources (Uses)	<u>36,415</u>	<u>38,432</u>	<u>2,017</u>
Net Change in Fund Balances	(4,849)	20,629	25,478
Fund Balances - Beginning	39,326	39,326	--
Fund Balances - Ending	<u>\$ 34,477</u>	<u>\$ 59,955</u>	<u>\$ 25,478</u>

CALDWELL COUNTY, TEXAS
COURTHOUSE SECURITY
SPECIAL REVENUE FUND
BUDGETARY COMPARISON SCHEDULE
FOR THE YEAR ENDED SEPTEMBER 30, 2018

EXHIBIT C-11

	<u>Budget</u>	<u>Actual</u>	<u>Variance Positive (Negative)</u>
Revenue:			
<i>Fees of office</i>	\$ 29,700	\$ 40,592	\$ 10,892
Total revenues	<u>29,700</u>	<u>40,592</u>	<u>10,892</u>
Expenditures:			
Current:			
<i>General administration</i>	416,634	361,291	55,343
Total Expenditures	<u>416,634</u>	<u>361,291</u>	<u>55,343</u>
Excess (Deficiency) of Revenues Over (Under) Expenditures	<u>(386,934)</u>	<u>(320,699)</u>	<u>66,235</u>
Other Financing Sources (Uses):			
<i>Transfers in</i>	386,934	386,934	--
Total Other Financing Sources (Uses)	<u>386,934</u>	<u>386,934</u>	<u>--</u>
Net Change in Fund Balances	--	66,235	66,235
Fund Balances - Beginning	190,661	190,661	--
Fund Balances - Ending	<u>\$ 190,661</u>	<u>\$ 256,896</u>	<u>\$ 66,235</u>

CALDWELL COUNTY, TEXAS
DEBT SERVICE FUND
BUDGETARY COMPARISON SCHEDULE
FOR THE YEAR ENDED SEPTEMBER 30, 2018

EXHIBIT C-12

	Budget	Actual	Variance Positive (Negative)
Revenue:			
<i>Taxes</i>	\$ 1,237,133	\$ 1,416,605	\$ 179,472
<i>Investment earnings</i>	3,500	15,673	12,173
Total revenues	<u>1,240,633</u>	<u>1,432,278</u>	<u>191,645</u>
Expenditures:			
Current:			
Debt Service:			
<i>Principal</i>	816,500	816,830	(330)
<i>Interest and fiscal charges</i>	402,824	402,822	2
Total Expenditures	<u>1,219,324</u>	<u>1,219,652</u>	<u>(328)</u>
Net Change in Fund Balances	21,309	212,626	191,317
Fund Balances - Beginning	744,843	744,843	--
Fund Balances - Ending	<u>\$ 766,152</u>	<u>\$ 957,469</u>	<u>\$ 191,317</u>

CALDWELL COUNTY, TEXAS
COMBINING STATEMENT OF FIDUCIARY ASSETS AND LIABILITIES
AGENCY FUNDS
SEPTEMBER 30, 2018

	<u>District Attorney</u>	<u>District Clerk</u>	<u>County Clerk</u>
ASSETS:			
<i>Cash and cash equivalents</i>	\$ 36,136	\$ 490,967	\$ 1,384,623
<i>Other receivables</i>	--	--	--
<i>Intergovernmental</i>	--	--	--
Total Assets	<u>\$ 36,136</u>	<u>\$ 490,967</u>	<u>\$ 1,384,623</u>
LIABILITIES:			
<i>Accounts payable</i>	\$ --	\$ --	\$ --
<i>Due to governmental funds</i>	--	--	--
<i>Due to other governments</i>	--	--	--
<i>Due to others</i>	36,136	490,967	1,384,623
Total Liabilities	<u>\$ 36,136</u>	<u>\$ 490,967</u>	<u>\$ 1,384,623</u>

County Sheriff	Elections	Unclaimed Moneys	Juvenile Probation Fund	Total Agency Funds (See Exhibit A-7)
\$ 261,611	\$ 4,886	\$ 634	\$ 551,847	\$ 2,730,704
--	--	--	3,051	3,051
--	--	--	304,605	304,605
<u>\$ 261,611</u>	<u>\$ 4,886</u>	<u>\$ 634</u>	<u>\$ 859,503</u>	<u>\$ 3,038,360</u>
\$ --	\$ --	\$ --	\$ 82,690	\$ 82,690
--	--	172	645,064	645,236
--	--	--	131,749	131,749
261,611	4,886	462	--	2,178,685
<u>\$ 261,611</u>	<u>\$ 4,886</u>	<u>\$ 634</u>	<u>\$ 859,503</u>	<u>\$ 3,038,360</u>

This page is left blank intentionally.

24. Discussion/Action to discuss approving Farmer's Market Courthouse Lawn use application. **Cost: None; Speaker: Judge Haden; Backup: 6**

Caldwell County Agenda Item Request Form

To: All Elected Officials and Department Heads – Hand deliver or scan & email to hoppy.haden@co.caldwell.tx.us and ezzy.chan@co.caldwell.tx.us . Deadline is 5:00 pm Tuesday before the Regular meetings, however, please submit this completed form ASAP. "Anything missing will cause the Agenda Item to be held over to the next Regular meeting," according to our Rules & Procedures.

AGENDA DATE: 5/13/2019

Type of Agenda Item

- Consent
- Discussion/Action
- Executive Session
- Workshop
- Public Hearing

What will be discussed? What is the proposed motion?

to discuss approving Farmer's Market Courthouse Lawn use application.

1. Costs:

Actual Cost or Estimated Cost \$ None

Is this cost included in the County Budget? _____

Is a Budget Amendment being proposed? _____

2. Agenda Speakers:

Name	Representing	Title
(1) <u>Judge Haden</u>		
(2) _____		
(3) _____		

3. Backup Materials:

None To Be Distributed 6 total # of backup pages (including this page)

4. 
Signature of Court Member

5/7/2019
Date

CALDWELL COUNTY
EVENT APPLICATION FOR COURTHOUSE LAWN USE

THE APPROVAL PROCESS MAY TAKE UP TO 7 BUSINESS DAYS. FAILURE TO FILE THE APPLICATION WITH THE COUNTY JUDGE IN SUFFICIENT TIME MAY RESULT IN DENIAL FOR A PERMIT FOR THIS ACTIVITY.

EVENT / ACTIVITY

NAME OF MAIN EVENT: FARMERS MARKET

DATE OF EVENT: FROM Every Saturday 7:30 to 3pm TO 1st Friday 4:30pm to 7pm

TIME OF EVENT: 7:30 3pm Sat. 4:30 to 7pm 1st Friday

TYPE OF ACTIVITIES (you may use a separate sheet of paper to describe daily events)
Farmers Market

Set up Date/Time: Sat. 7:30am 1st Fri. 4:30pm

Break down Date/Time: 3pm 7pm

EVENT SPONSOR (Name of group, organization, or individual sponsoring this activity)

NAME: Clem Wilson + Doris Voigt

PHYSICAL ADDRESS: [REDACTED] Old Lytton Springs Rd

MAILING ADDRESS (if different) Same

TELEPHONE NUMBER: [REDACTED]

CALDWELL COUNTY

EVENT APPLICATION FOR COURTHOUSE LAWN USE

APPLICANT (PERSON IN CHARGE OF THE EVENT / ACTIVITY / LAWN USE AND CARE)

NAME Clem Wilson & Doris Voigt

PHYSICAL ADDRESS [REDACTED] Old Lytton Springs Rd

MAILING ADDRESS (if different) SAM

EMAIL: [REDACTED]@ranchwireless.com

TEL./CELL NUMBER [REDACTED]

D.L.#/ I.D Card # [REDACTED]

LOCATION OF ACTIVITY

Please indicate which side of Courthouse you will be utilizing

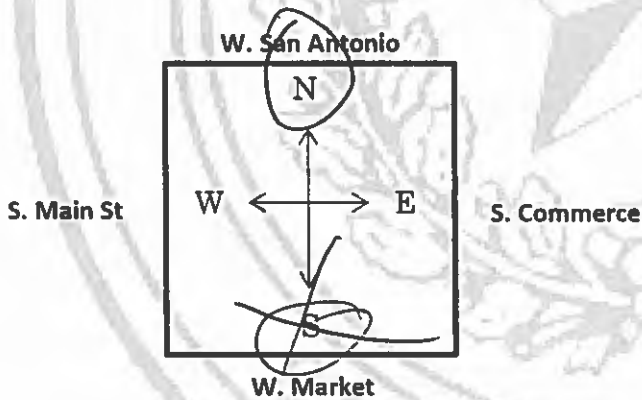

- Street Closure Required:**
- North (W. San Antonio St.)
 - East (S. Commerce St.)
 - West (S. Main St.)
 - South (W. Market St.)

Will any street closures be required? YES NO

If so, which street(s) List or check above _____

If yes, has City of Lockhart been notified? YES NO

Dates and time that streets will be closed every Sat. & 1st Friday

**CALDWELL COUNTY
EVENT APPLICATION FOR COURTHOUSE LAWN USE**

CITY OF LOCKHART	
HAVE YOU OBTAINED A PERMIT FROM CITY OF LOCKHART	N/A
IF NO, WHY _____	___ YES ___ NO
IS THE ACTIVITY OPEN TO THE PUBLIC?	___ YES (___ NO)
IF NOT, WHO WILL MONITOR ADMITTANCE _____	N/A
ESTIMATED NUMBER OF PEOPLE TO ATTEND _____	

I, the undersigned applicant, hereby affirm that I am the person who is responsible for this activity. I understand that any false or misleading statement in this application is grounds for denial of a permit, or if one has already been issued, grounds for its' revocation. I also understand that I am responsible for compliance with all applicable laws and any other requirements set forth for the issuance of this permit.

Doris Vaigt
Applicant's Signature

4-26-20
Date

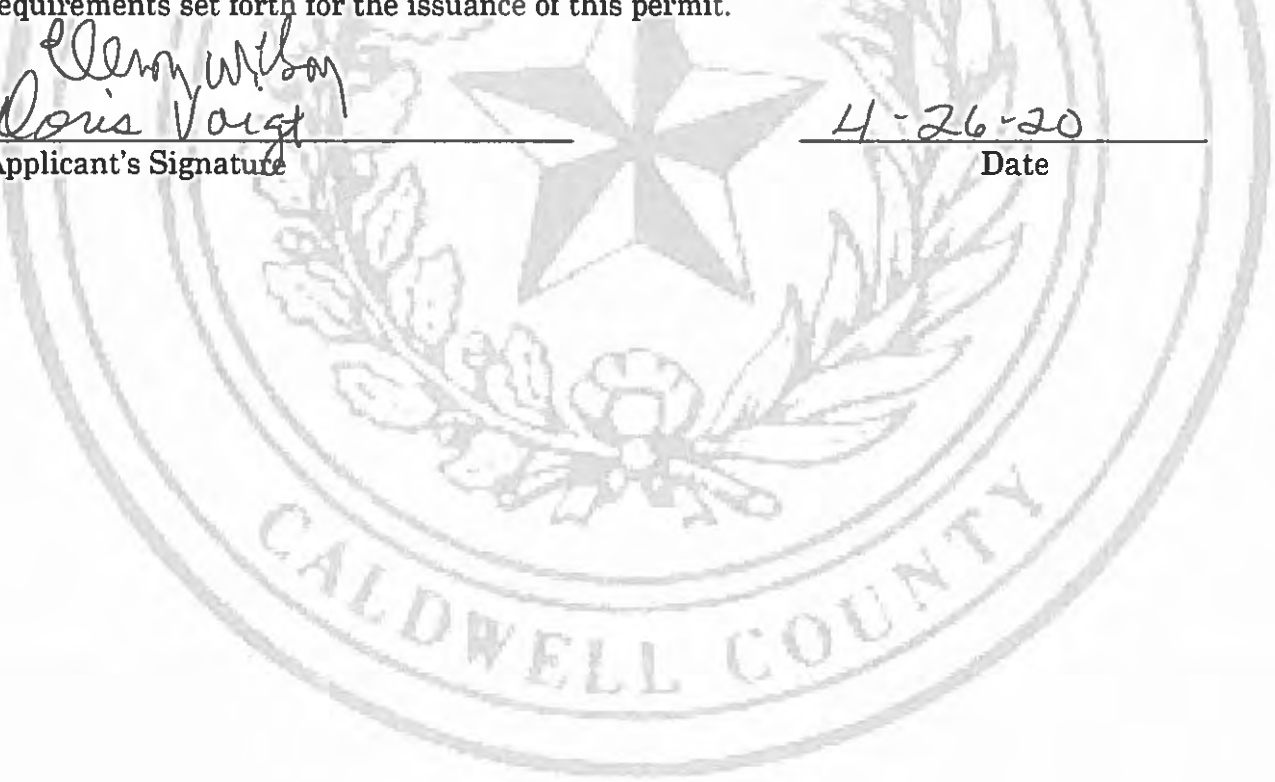

**CALDWELL COUNTY
EVENT APPLICATION FOR COURTHOUSE LAWN USE**

NAME OF EVENT / ACTIVITY: Farmer's Market

Approved

Denied

Reason Denied: _____

Judge's Signature

Date

CALDWELL COUNTY
EVENT APPLICATION FOR COURTHOUSE LAWN USE

The following rules must be adhered to by the organization using the Courthouse facilities and lawn.

1. Tarps or any other covers are not to be placed directly on the lawn by vendors, nor can they be staked directly into the lawn, they can be weighed down if necessary.
2. Items such as confetti, pop rocks, silly string, pellet guns, etc., or any other items that would leave a residue on the lawn, cannot be sold or given away at the festivities.
3. The event sponsor will be responsible for picking up and disposing of all trash accumulated during the event on and around the Courthouse grounds.
4. Caldwell County will supply one (1) trash bag per receptacle around the Courthouse. You will be responsible for supplying the rest.
5. No motorized vehicles can be driven on the lawn with the exception of motorized chairs used by handicapped persons.
6. No paint of any kind can be used on the lawn.
7. *The organization holding the event is responsible for leaving the grounds the way they found them – clean and unharmed.*
8. A member in charge of the vendors and/or the sponsoring organization must be present during set-up times to ensure compliance with these rules.
9. Each organization will be held responsible for any damages incurred to the grounds and/or Courthouse during the event.
10. A copy of the Vendor application from City of Lockhart must be submitted to the County Judge along with this application showing what restrictions will be in force during the festivities. (if applicable)
11. Submit 2 copies of this application to the County Judge at least eight (8) weeks prior to a major event (i.e. Cinco de Mayo or Hot Rod and Hatters) or two (2) weeks prior to smaller events (i.e. Veterans Day event or National Day of Prayer.)
12. Any variance to these rules must be approved by the County Judge.

Responsible Party: *Cleron Wilson* Date: *4-26-20*
Rona Vaigt

Judge's Signature: _____ Date: _____

25. Discussion/Action to approve the Interlocal Cooperative Agreement between Caldwell County and the City of Luling for subdivision regulation within the extraterritorial jurisdiction of the City of Luling. **Cost: None; Speaker: Judge Haden; Backup: 7**

Caldwell County Agenda Item Request Form

To: All Elected Officials and Department Heads – Hand deliver or scan & email to hoppy.haden@co.caldwell.tx.us and ezzy.chan@co.caldwell.tx.us . Deadline is 5:00 pm Tuesday before the Regular meetings, however, please submit this completed form ASAP. "Anything missing will cause the Agenda Item to be held over to the next Regular meeting," according to our Rules & Procedures.

AGENDA DATE: 5/13/2019

Type of Agenda Item

- Consent Discussion/Action Executive Session Workshop
 Public Hearing

What will be discussed? What is the proposed motion?

To approve the Interlocal Cooperative Agreement between Caldwell County and the City of Luling for subdivision regulation within the extraterritorial jurisdiction of the City of Luling.

1. **Costs:**

Actual Cost or Estimated Cost \$ None

Is this cost included in the County Budget? _____

Is a Budget Amendment being proposed? _____

2. **Agenda Speakers:**

Name	Representing	Title

(1) Judge Haden

(2) _____

(3) _____

3. **Backup Materials:** None To Be Distributed 87 total # of backup pages
(including this page)

4. 

Signature of Court Member

Date 4/29/19

**STATE OF TEXAS §
COUNTY OF CALDWELL§**

**INTERLOCAL COOPERATIVE AGREEMENT
BETWEEN ON CALDWELL COUNTY AND THE CITY OF LULING
FOR SUBDIVISION REGULATION WITHIN THE EXTRATERRITORIAL
JURISDICTION OF THE CITY OF LULING.**

THIS INTERLOCAL COOPERATION AGREEMENT (THIS "Agreement") is made and entered into by and between CALDWELL COUNTY, Texas, a political subdivision of the State of Texas (hereinafter referred to as "COUNTY"), by and through its County Judge, and the City of Luling, a municipal corporation of the State of Texas (hereinafter referred to as "CITY"), by and through its Mayor.

WHEREAS, the CITY has duly identified its corporate limits and the areas of its extraterritorial jurisdiction (herein referred to as "ETJ" or the "CITY'S ETJ") within the COUNTY; and

WHEREAS, the COUNTY has adopted and is enforcing subdivision regulations pursuant to Texas Local Government Code section 232.002 through 232.005 and other statutes applicable to counties; and

WHEREAS, the COUNTY and the CITY, pursuant to Texas Local Government Code section 242.001(d)(1), entered into an Interlocal agreement for enforcement of subdivision regulations in the CITY's ETJ, and the parties wish to enter into a new Agreement; and

WHEREAS, to the extent that the CITY's execution of this Agreement and related agreements with other counties in other areas of the CITY's ETJ, or the CITY's adoption, administration or enforcement of ordinances, rules, regulations, or plans in reasonable furtherance of this Agreement or the related agreements results in requirements or restrictions that are not identical throughout the CITY'S entire ETJ, the parties jointly acknowledge that the actions of the CITY are "reasonably taken to fulfill an obligation mandated by state law" within the meaning of chapter 2007 of the Texas Government Code; and

NOW THEREFORE, the County and the CITY mutually agree as follows:

I. TERM OF AGREEMENT AND CERTIFICATION

- A. The COUNTY and the CITY mutually agree that the term of this Agreement shall be from the date it is formally and duly executed by both the COUNTY and the CITY until which time this Agreement shall automatically renew for successive terms of five (5) years, unless earlier terminated by mutual agreement of the parties.
- B. Notwithstanding the foregoing, this Agreement may be terminated by either party by giving thirty (30) days written notice of intent to terminate this Agreement to the other party. Any notice of intent to terminate must be delivered by deposit in the United States mail, certified, return receipt requested, to the other party at the addresses set out herein. Upon termination of this Agreement, neither party shall have any obligations to the other party under this Agreement, except with respect to payment for services already rendered under this Agreement, but not yet paid.

- C. The COUNTY and the CITY mutually certify that this Agreement complies with the requirements of chapter 242 of the Texas Local Government Code.

II. COUNTY RESPONSIBILITIES

- A. The COUNTY assigns and delegates to the CITY the COUNTY's authority to approve subdivision plats and to issue related permits within the ETJ of CITY, pursuant to section 242.001(d) of the Texas Local Government Code, so that the CITY has exclusive jurisdiction to regulate subdivision plats and approve related permits in the CITY'S ETJ.

III. CITY RESPONSIBILITIES

- A. The CITY shall enforce its subdivision regulations, including review and approval processes and design and construction standards, within its ETJ.
- B. The CITY shall enforce in the ETJ the COUNTY's subdivision regulations which are contained in the Caldwell County Development Ordinance, adopted on August 13, 2018, as amended, which is attached hereto as Exhibit A, and incorporate herein by this reference as if fully set forth herein, unless the CITY has existing ordinances establishing substantially similar, or more stringent, standards for the subject areas of such COUNTY subdivision regulations. ALL CITY subdivision regulations not in conflict with Attachment A, and CITY regulations establishing more stringent standards for the subject areas in Attachment A, may be enforced. If either party wishes to propose revisions in the future to subdivision regulations that apply in the ETJ, the party will notify the other party of the proposed change. The parties will cooperate in determining the need for the change and its effect on this Agreement and will adopt any change agreed to by official action of their respective governing bodies.
- C. The CITY agrees to require developers to dedicate public right of way pursuant to any County Transportation Plan adopted by the COUNTY subject to applicable constitutional and statutory limitations. For subdivisions in which it appears to the CITY that a requirement for dedication of right of way pursuant to such County Transportation Plan may exceed an applicable constitutional or statutory limitations, the CITY will notify the COUNTY, and the parties will cooperate to determine the extent of right of way dedication be required, or an alternative method of securing the needed right of way. When enforcing subdivision regulations in the CITY's, ETJ, the CITY shall facilitate the COUNTY's road maintenance program by requiring a road standard no less than the standards set out in Attachment A.
- D. The COUNTY expressly delegates to the CITY the authority, in accordance with the COUNTY's subdivision regulations, to require the preparation of a subdivision plat for the division of any property into two or more lots if any lot in the subdivision is 10 acres or less in size.
- E. The CITY shall deliver two copies of all recorded plats for subdivisions within the CITY's ETJ to the COUNTY within ten (10) working days of the recording of the subdivision plat. The CITY shall also provide to the COUNTY a digital file of each subdivision plat, including at least two ground control GPS points in a format approved by the COUNTY.

- F. The CITY shall confer with the Caldwell County 911 Addressing Division or the COUNTY's designated representative concerning street names prior to final plat approval.
- G. The CITY shall allow COUNTY inspectors access to road construction sites of subdivisions within the ETJ and the CITY shall timely submit copies of all road design materials and road construction test results to the COUNTY during road construction. COUNTY inspectors shall have inspection and approval authority over the road construction, storm water drainage construction, and water and wastewater facility construction within the right of way and easements. However, COUNTY inspectors may, from time to time, collaborate with CITY inspectors and delegate to CITY inspectors specific inspection duties related to road construction, stormwater drainage construction, and/or water and wastewater facility construction within the right of way and easements. The COUNTY may request that the CITY issue a stop-work notice if the applicable construction standards are not being met.
- H. Prior to acceptance of new streets or other improvements in a subdivision, the CITY shall require of the applicant/developer a Certificate of Deposit, a Letter of Credit, or a warranty or cash bond as required by the Development Ordinance of Caldwell County, payable to Caldwell County, which shall be binding for two (2) years from the date of acceptance of the streets and improvements. The CITY shall require the applicant/developer to be responsible for maintenance of the streets and improvements as also required by the Caldwell County Development Ordinance. The CITY shall require the applicant/developer to post a utility bond or other improvements bond, payable to the CITY, if required by the subdivision regulations of the CITY. The CITY shall not be liable for failure to require any such utility bond.
- I. The CITY shall collect and forward to the COUNTY all COUNTY subdivision fees, as set forth on the Caldwell County Subdivision and Development Fee Schedule, as presently authorized or amended by the COUNTY, for services to be performed by COUNTY. Said COUNTY fees include, but are not limited to, plat fees, work in right-of-way (road cut, driveway and utility) permit fees, construction permit fees, flood plain revision fees, subdivisions construction fees, along with any and all consulting fees, and residential construction permit fees. In addition, the CITY shall have the right to also charge applicants/developers its own reasonable fees, sufficient to cover the full cost of services provided by the CITY under this Agreement and otherwise in the administration of regulations that apply to subdivisions in the CITY's ETJ. A copy of the COUNTY's existing fee schedule is attached hereto as Exhibit B, and incorporated herein by this reference as if fully set forth herein. The CITY agrees to contact the Caldwell County Subdivision Coordinator to ascertain the proper fees to be applied to each subdivision plat application prior to the first hearing of the application by the CITY.
- J. If a fee, Certificate of Deposit, Letter of Credit, warranty, or bond is to be forwarded to the COUNTY in accordance with this Agreement, the CITY shall promptly forward the fee, Certificate of Deposit, Letter of Credit, warranty, or bond to the Office of the County Judge, Caldwell County Courthouse, Room 201, 110 South Main Street, Lockhart, Texas 78644.

- K. The City agrees that if any subdivision is to be approved in the ETJ that involves the use of septic tanks, then the COUNTY shall have exclusive jurisdiction over approval, permitting, regulation, and inspection of such systems.
- L. As an attachment to this Agreement, the CITY shall provide a current map(s) defining the legal boundaries of its corporate limits and areas of ETJ. The CITY shall notify the COUNTY of any changes to the CITY's ETJ within ten (10) days of the effective date of the change, and the area covered by this agreement shall be deemed by the parties to be amended accordingly. A change in the area covered by this Agreement shall not, however, affect any rights accrued under chapter 245 of the Texas Local Government Code prior to the effective date of the change. Notice of any change shall be sent to the office of the County Judge at the address set forth above.
- M. The CITY shall submit for review by the COUNTY facility planning reports supporting the proposed subdivision as required in chapter 285 of title 30 of the Texas Administrative Code, directly to the Caldwell County Sanitation Department.
- N. The CITY shall review flood plain drainage analysis of FEMA regulated flood plans that are submitted in connection with proposed subdivision plans for compliance with the Caldwell County Flood Damage Prevention Order.
- O. The CITY shall provide the COUNTY with a copy of any complete subdivision application for its review, and shall consider all written comments and recommendations, if any, received from the COUNTY within twenty-one (21) days of receipt of the application, and shall integrate all such written comments and recommendations into any comments that are provided to the applicant/developer.

IV. GENERAL PROVISIONS

- A. **General Administration:** Administering this Agreement and the contact person for the COUNTY shall be the Caldwell County Subdivision Coordinator or his or her representative. Administering this Agreement and the contact person and representative for the CITY shall be the City Manager, or his or her designee.
- B. **Alteration, Amendment or Modification:** This Agreement may not be altered, amended, or modified except in a subsequent writing signed by all parties to this Agreement. No official, agent, employee, or representative of either the COUNTY or the CITY has the authority to alter, amend, or modify the terms of this Agreement, except in accordance with express authority as may be respectively granted by either the Caldwell County Commissioners Court or the City of Luling City Council.
- C. **Notice:** All notices sent pursuant to this Agreement shall be in writing and must be sent by registered or certified mail, postage prepaid, return receipt requested.
 - (a) Notices sent pursuant to this Agreement shall be sent to the Caldwell County Subdivision Coordinator's Office at the following address:

Kasi Miles
Caldwell County Sanitation Department

1700 FM 2720
Lockhart, Texas 78644

- (b) To be effective, a copy of any notice sent to the COUNTY shall be sent to the COUNTY's attorney at the following address:

Amanda Montgomery
Assistant District Attorney – Civil
Caldwell County
Justice Center
1703 S. Colorado Street
Lockhart, Texas 78644

- (c) Notices sent pursuant to this Agreement may be delivered or sent to the CITY at the following address:

Mark Mayo
Luling City Manager
509 E. Crockett St.
Luling, TX 78648

- (d) To be effective, a copy of any notice sent to the CITY shall be sent to the CITY's attorney at the following address:

Peter Grunning - Attorney at Law
P.O. Box 314
San Marcos, TX. 78667-0314

- (e) When notices sent pursuant to this Agreement are mailed by registered or certified mail, notice shall be deemed effective three (3) days after deposit in a U.S. mail box or at a U.S. post office.

- D. **Severability:** If any provision of this Agreement is found to be invalid, illegal, or unenforceable, such invalidity, illegality, or unenforceability shall not affect the remaining provisions of this Agreement.
- E. **Breach:** The failure of either party to comply with the terms and conditions of this Agreement shall constitute a breach of this Agreement. However, the parties agree to work together to resolve disputes arising under this Agreement, including a breach, and neither party shall be liable to the other party for any errors or omissions in the review or approval of an application or in the inspection of infrastructure installations. In the event of an alleged breach or other dispute, notice shall be provided to the other party as provided in Section IV.C, and the parties shall cooperate in an attempt to resolve such breach or dispute for a period of at least 60 days, prior to sending notice of termination under section I.B., or taking any other remedial action.
- F. **Non-Waiver:** The waiver by either party of a breach of this Agreement shall not constitute waiver of such breach or of a subsequent breach of the same or a different

provision. Nothing in this Agreement is intended by either party to constitute a waiver of any immunity from suit or liability to which it is entitled under applicable law.

G. **Entire Agreement: Third Parties:** This Agreement constitutes the entire agreement between the COUNTY and the CITY. No other agreement, statement, or promise relating to the subject matter of this Agreement which is not contained in this Agreement or incorporated by reference in this Agreement shall be valid or binding. This Agreement is not intended to confer any rights on any third parties.

H. **Terms Used in Document:** As used in this document, the terms "Interlocal Cooperation Agreement", "Interlocal Agreement", "Agreement", and "Contract" are synonymous.

I. **Non-Defined Terms:** If not specifically defined in this Agreement, words and phrases used in this Agreement shall have their ordinary meaning as defined by common usage.

EXECUTED THIS _____ DAY OF _____, 2019.

By: _____
Hoppy Haden
Caldwell County Judge

Attest:

Teresa Rodriguez, Caldwell County Clerk

Date: _____

EXECUTED THIS 11th DAY OF April, 2019.

CITY OF LULING

By: _____
Mike Hendricks, Mayor



Martha C. Velasquez, Luling City Secretary

Date: 4-12-19

26. Discussion/Action requesting approval to purchase and issue purchase order for the Unit Road equipment from Freightliner of Austin. **Cost:\$783,598.32; Speakers: Judge Haden/ Danie Blake; Backup: 101**

Caldwell County Agenda Item Request Form

To: All Elected Officials and Department Heads – Hand deliver or scan & email to hoppy.haden@co.caldwell.tx.us and ezzy.chan@co.caldwell.tx.us . Deadline is 5:00 pm Tuesday before the Regular meetings, however, please submit this completed form ASAP. "Anything missing will cause the Agenda Item to be held over to the next Regular meeting," according to our Rules & Procedures.

AGENDA DATE: 5/13/2019

Type of Agenda Item

- Consent Discussion/Action Executive Session Workshop
 Public Hearing

What will be discussed? What is the proposed motion?

Requesting approval to purchase and issue purchase order for the equipment purchase from Freightliner of Austin for the Belly Dump (2x), Belly Dump Tractor (2x), Dump Trucks (4x), and Water Truck (1x) in the total amount of \$783,598.32.

1. **Costs:**

Actual Cost or Estimated Cost \$ 783,598.32

Is this cost included in the County Budget? _____

Is a Budget Amendment being proposed? _____

2. **Agenda Speakers:**

	Name	Representing	Title
(1)	Danie Blake		Purchasing Agent
(2)			
(3)			

3. **Backup Materials:** None To Be Distributed 101 total # of backup pages
(including this page)

4. 
Signature of Court Member

Date 5/17/2019

Commissioners Court-Monday May 13, 2019
County Purchasing Department
Caldwell County Freightliner Equipment Purchase

Discussion Items:

The Purchasing Department requests approval to purchase the following equipment from Freightliner of Austin: two (2) new 2019 CTS 32FT Belly Dump Trailers at the price of \$33,821.16 each, making the total **\$67,642.32**. Two (2) new 2020 M2-112 Day Cab Tractor (for belly dump trailer) priced at \$99,750.00 each, making total **\$199,500.00**. Four (4) new 2020 M2-106 Dump Truck priced at \$105,939.00, making a total of **\$423,756**. Lastly, one (1) new 2020 M2-106 Water Truck at the price of **\$93,500.00**. We will also need to deduct an additional \$800.00 of separate buy board fees fixed into the cost of Belly Dump and Tractor pricing. With the total purchase price of all equipment coming out to **\$783,598.32**. The projected amount of spending cost was estimated at \$810,000, after thorough negotiations and diligent efforts by multiple departments, the county was able to have a cost savings of \$26,401.68.

With the approval of purchase, the Purchasing Agent will have the County Judge and County Auditor sign off on the Purchase Order.

Notable Budget Items: \$783,598.32 from the Certificate of Obligation Funds.

Recommendation to Commissioner's Court:

County Purchasing Department respectfully recommends the following:

Requesting approval to purchase and issue a purchase order for the equipment purchase from Freightliner of Austin for the Belly Dump, Belly Dump Tractor, Dump Trucks, and Water Truck in the amount of \$783,598.32.

Department Head Signature:

Daniel Blake 5-7-19

Caldwell County Unit Road Equipment

Belly Dump Trailer	Make/Model:	Price	
Alamo City Trailer Sales, LLC	2020 Armor Lite	\$ 31,700.00	<i>*Did not have the correct size * Quoted us on 40FT not 32FT*</i>
Freightliner	2019 32FT Pack Mule Trailer	\$ 33,821.16	
Performance Trailer - Buda	2020 CPS Bottom Dump Trailer	\$ 34,311.25	

Tractor's for Belly Dump Trailers

Freightliner	M2-112 Day Cab Tractor	\$ 99,750.00
Vanguard	2020 Mack P164T	\$ 110,534.18
Rush Truck Centers	2019 Peterbilt 567	\$ 123,865.71

14 YD Dump Trucks

Freightliner	M2-106 Dump Truck	\$ 105,939.00
Rush Truck Centers	2019 Peterbilt 348	\$ 117,663.52
Vanguard	2019 Mack GR64F9	\$ 128,612.06
Grande Truck Center	2020 Western Star 4700 Cummins 9L Engine	\$ 138,641.58
Grande Truck Center	2020 Western Star 4700 Detroit 13L Engine	\$ 146,326.65

Water Truck

Rush Truck Center	2018 F-750 Ford	\$ 70,450.00	
Rush Truck Center	2018 Hino - Water Truck	\$ 93,451.25	
Freightliner	2020 M2-106 Water Truck	\$ 93,500.00	<i>*Newer Model with an extra coating on the inside of tank. Longer lifetime Warranty*</i>

Total Cost on Belly Dump & Tractors (2x):	\$	267,142.32
Total Cost on 14 YD Dump Trucks (4x):	\$	423,756.00
Total Cost on Water Truck (1x):	\$	93,500.00
Minus \$800 for Additional BuyBoard Fee	\$	(800.00)
Total Combined Purchase Cost	\$	783,598.32

Total Savings off projected cost: \$ 26,401.68

Unit Road Caldwell County

From: kevin beran [REDACTED]
Sent: Friday, March 29, 2019 10:40 AM
To: unitroad@co.caldwell.tx.us
Subject: 2019-CIS 32FT. Pack Mule Belly Dump Trailer-Spec & Quote
Attachments: SAccounting19032909200.pdf

Hello Mike,

Attached is the trailer spec and buy board quote for you to consider.

The only truck I have left to quote is the water truck. I have the chassis spec ready, however I'm waiting on the tank body builder to get me his spec and quote.

If I don't have it to you today, it will be sent to you no later than Monday.

Thanks again, for considering us for your Trucking needs!

Have a GREAT day, 🍀

Kevin Beran
Freightliner of Austin
512-619-5152- Cell Phone
512-389-0000- Office- Ext.104



FREIGHTLINER OF AUSTIN

1701 Smith Rd.
Austin, Texas 78721

Bus: 512-389-0000
Fax: 512-389-2663

INV #:

BUYER'S ORDER

BUYER'S NAME CALDWELL COUNTY		PHONE 512-398-7268	
ADDRESS 110 SOUTH MAIN ST.		CITY LOCKHART	STATE TX
YEAR 2019	MAKE CTS	MODEL/BODY 32FT. PACK MULE TRAILER	VIN
		ORDER PROPOAL	
		ZIP CODE 78644	LICENSE PLATE

A DOCUMENTARY FEE IS NOT AN OFFICIAL FEE. A DOCUMENTARY FEE IS NOT REQUIRED BY LAW, BUT MAY CHARGED TO BUYER FOR HANDLING DOCUMENTS RELATING TO THE SALE. A DOCUMENTARY FEE MAY NOT EXCEED A REASONABLE AMOUNT AGREED TO BY THE PARTIES. THIS NOTICE IS REQUIRED BY LAW.

UN CARGO DOCUMENTAL NO ES UN CALGO OFICIAL. LA LEY NO EXIGE QUE SE IMPONGA UN CARGO DOCUMENTAL. PERO ESTE PODRIA COBRARSE A LOS COMPRADORES POR EL MANEJO DE LA DOCUMENTACION EN RELACION CON LA VENTA. UN CARGO DOCUMENTAL NO PUEDE EXCEDER UNA CANTIDAD PASONABLE ACORDADA POR LAS PARTES. ESTA NOTIFICACION SE EXIGE POR LEY.

Disclaimer of Warranties

The above described vehicle sold by Freightliner of Austin is sold as is, without either express or implied warranties of any kind by Freightliner of Austin, including warranties of merchantability or fitness, and Buyer will bear the entire expense of repairing or correcting any defects that presently exist or that may occur in the vehicle, unless a written warranty, or service contract with Freightliner of Austin covering the described vehicle is delivered to Buyer in conjunction with or within 90 days following the time of sale, but such vehicle or any of its component parts may be subject to warranty by the manufacturer thereof.

MILEAGE:	
SELLING PRICE	\$33,821.16
INCLUDES BUY BOARD FEE	
ADDITIONAL EQUIPMENT:	
MANUAL CRANK-ARM TARPING SYSTEM	

MILEAGE:	YEAR	MAKE	MODEL/BODY	VIN	
MILEAGE:	YEAR	MAKE	MODEL/BODY	TRADE-IN	VIN
PAYOFF TO:				TOTAL	\$33,821.16
ADDRESS:				(Trade Allowance)	
				TRADING DIFFERENCE	
				SALES TAX	N/A
GOOD UNTIL:				DEALER'S INVENTORY TAX	N/A
QUOTED BY:				LICENSE FEE	N/A
SHOW LEIN TO:				DOCUMENTARY FEE	N/A
ADDRESS:				FEDERAL EXCISE TAX	N/A
				State Insp.:	TOTAL SALE PRICE
DATED:				LIEN AMOUNT \$	\$33,821.16
DRAFT FOR \$				License:	PAYOFF ON TRADE
DRAFT THRU:				Title:	EXT SERVICE AGREEMENT
ADDRESS:				Transfer:	LESS DEPOSIT
					X 2
				Total Balance Due	\$67,642.32

county tax assessor-collector, is not a tax imposed on a consumer by the government, and is not required to be charged by the dealer to the consumer. The information you see on the window form for this vehicle is part of this contract. Information on the window form overrides any contrary provisions on the contract of sale. La informacion que aparece en la ventanilla de este vehiculo forma parte de este contrato. La informacion contenida en el formulario de la ventanilla anula cualquier provision que estable contrato y que aparece en el contrato de venta. If a credit purchase, this is an offer to purchase only. Buyer offers to purchase vehicle on credit terms described herein and no contract relationship is created. This order does not constitute an agreement for the extension of credit. Manufacturer/Distributor reserves the right to change the price of new vehicles to Seller without notice. In the event that the price to Seller of the new vehicle ordered hereunder is changed prior to delivery to Buyer, Buyer agrees and accepts that the cash delivered price will be changed accordingly. If the Buyer's used vehicle trade-in is not delivered to the Seller until delivery of the new vehicle, the trade-in will be reappraised at that time and Buyer agrees that such reappraised value will determine the allowance, if any, made for the trade-in. Buyer agrees to deliver the original bill of sale and the title to an trade-in along with the delivery of the trade-in and further agrees to execute and all documents necessary or required to transfer legal title and ownership to Seller or its assigns. Buyer warrants the trade-in to be his property and free and clear of all liens and encumbrances except as otherwise noted herein. Buyer further warrants that the trade-in has not been declared rebuilt salvage, reconditioned, nonrepairable, or flood damaged and that the emission systems have not been tampered with and are in the condition as originally manufactured, except for ordinary wear, unless so disclosed. Seller makes no representations, concerning fuel economy of the sale and any information posted on the sale unit or contained in literature relating to the same reflect the results of tests performed, required or prescribed by government agency, upon which Seller relied. It is expressly agreed to and understood by Buyer and Seller that in the event of a non-credit transaction, Seller retains a security interest in the purchased vehicle until such time as Buyer paid the Seller for the vehicle. Buyer agrees to all the above listed charges.

BUYER'S SIGNATURE: _____ SELLER'S SIGNATURE _____ DATE _____
AUSTIN TRUCK & EQUIPMENT, LTD. DBA FREIGHTLINER OF AUSTIN



2535 Rose Parkway
Sikeston, MO 63801
www.construction-trailerspecialists.com

Quote Number: JDT031919
Quote Good for: 15 Days
Date: March 19, 2019
Lead Time: 3-5 weeks Pending Prior Orders

Customer Information		
Dealer:	Freightliner of Austin	Phone:
Location:		Cell:
Salesman:	Kevin B	Fax:
End Customer:		Email:

Factory Information			
Contact 1:	Jimmy D Thomas	Office:	888-869-0003
Contact 2:	Doug Schnetzer	Fax:	573-481-3953
Cell Phone:	573-803-7180	Email:	

Trailer Model: Standard "Pack Mule" Bottom Dump

Length: Ht: Width:

Standard Equipment	
Capacity:	20 C.Y. (Water Level), 23.5 C.Y. (Heaped)
Bang Boards:	10"
Gates:	3/16" AR 450 with Adjustable Side Locks Air Operated Gates with Electric Side Control Manual Air Valve Controlled from Ground Universal Doors
Lower Hopper:	Single Hopper with 54" x 108" Opening 3/16" AR 450 Plate with 10 GA. GR 50 Sidewalls
Upper Hopper:	16 & 12 GA. GR 50 Steel Material
Top Rail:	4" x 6" x 3/16" Tube ASTM A-36 Material
Bottom Rail:	4" x 6" x 3/16" Tube ASTM A-36 Material
Sides:	54" High Double Wall Corrugated Sides
5th Wheel:	Oscillating with 18" Kingpin Setting
Air System:	Two 8" Air Cylinders Water Trap and Oiler 60 Gallon Air Reservoir Quick Release Valves
Wheels:	8 8.25 x 24.5 Steel 10 Hole Steel Disc 0
Tires:	11R x 24.5 Radials
Tire Brand:	OEM
Axles:	Two OEM Standard 25,000# 5" Tubular 5/8" Wall 16 5" x 7" Brakes With ABS 2S1M (One Axle) 30 x 30 Brake Chambers Top Mounted Windrow Deflectors
Suspension:	H-9700, 50,000 lb.
Fenders:	Aluminum Front and Rear
Landing Gear:	Drop Leg 4" x 4" Square Tube Gate Mounted
Lights:	ICC and DOT Approved Grote Blue Seal System
Paint:	Standard
Color:	White
Tarp:	No Tarp Option
Tarp Brand:	OEM
Tarp Color:	

Optional Equipment			
Rims	Qty.	Price	Weight
<input type="checkbox"/> Brushed Aluminum Wheels (Each)	1	\$175	
<input type="checkbox"/> Polished Aluminum Wheels (Each)	1	\$200	
Tires	Qty.	Price	Weight
<input type="checkbox"/> Super Singles / Polished Alum. (Each)	1	\$375	
<input type="checkbox"/> 11R x 22.5 Radials		\$0	
<input type="checkbox"/> Low Profile 22.5 Radials 295/76		\$0	
<input type="checkbox"/> Duratum 11R x 24.5 Radials	1	-\$50.00	
Axles	Qty.	Price	Weight
<input type="checkbox"/> Spread Axle		\$500	
<input type="checkbox"/> Spring Ride 3rd Axle, 4 Tires, 71.5" Track		\$4,500	
<input type="checkbox"/> Air Ride 3rd Axle, OEM, 4 Tires - 71.5" Track		\$5,750	
<input type="checkbox"/> Lift Axle		\$850	
<input type="checkbox"/> Longer than 40' 2 Axle or 42' 3 Axle	1	\$350	
<input type="checkbox"/> 4S2M		\$200	
Tarp	Qty.	Price	Weight
<input type="checkbox"/> Best Manual Flip Tarp		\$1,100	
<input checked="" type="checkbox"/> Manual Flip & Go		\$1,300	
<input type="checkbox"/> Electric Flip & Go		\$1,500	
<input type="checkbox"/> Manual Slide & Go		\$1,700	
<input type="checkbox"/> Electric Slide & Go		\$2,100	
<input type="checkbox"/> Side Roll Electric with Roll Pole		\$2,000	
Suspensions	Qty.	Price	Weight
<input type="checkbox"/> Single Point 50k - 71.5" Track		\$2,600	
<input type="checkbox"/> Tandem OEM Air Ride - 71.5" Track		\$2,600	
<input type="checkbox"/> Tandem HT Air Ride - 71.5" Track		\$2,850	
<input type="checkbox"/> Tandem OEM Air Ride - 77.5" Track		\$2,850	
Additional Options	Qty.	Price	Weight
<input type="checkbox"/> Parallel Spindles		\$225	
<input type="checkbox"/> Versa Valve		\$300	
<input type="checkbox"/> Infinite Gate		\$500	
<input type="checkbox"/> Low Profile		\$800	
<input type="checkbox"/> Slope Sheets		\$400	
<input type="checkbox"/> Extended Push Block		\$150	
<input type="checkbox"/> Removable Extended Push Block		\$300	
<input type="checkbox"/> Steel Fenders		\$100	
<input type="checkbox"/> Cab Kit		\$100	
Miscellaneous	Qty.	Price	Weight
<input type="checkbox"/> Falcon Cylinders	1	\$700	
<input type="checkbox"/>			
<input type="checkbox"/>			
<input type="checkbox"/>			
<input type="checkbox"/>			

* Price does not include FET, State Tax or License Fees unless otherwise specified. * Special orders may require a 20% deposit.
* Payment is expected at time of completion, billing and availability. * A 1.5% monthly service charge will be assessed for delayed pickups beyond month's end

Customer Name _____

Customer Signature _____

Date _____

Weight: 12,700

Unit Road Caldwell County

From: Randy Ballard [REDACTED]
Sent: Friday, April 12, 2019 9:18 AM
To: unitroad@co.caldwell.tx.us
Cc: Randy Ballard
Subject: Quote on Armor Lite Bottom Dump
Attachments: doc00449420190412091346.pdf

Mike,

Here is the quote on the 2 Bottom Dumps, I will get you the other quote as soon as I can. Let me know if you have any questions.

Thank You,
Randy Ballard
Alamo City Trailer Sales, LLC
17515 IH-10 East
Luling Tx 78648- Exit 625
(830)400-1960- Office
(830)837-2997-Cell
randy@alamocitytrailersales.com



-----Original Message-----

From: alamocityscans@mail.com [mailto:alamocityscans@mail.com]
Sent: Friday, April 12, 2019 9:14 AM
To: Randy Ballard
Subject:

ECOSYS M3645idn
[00:17:c8:6c:5e:24]

Belly Dumps
(2x)

Alamo City Trailer Sales, LLC.

Trailer Sales, Rental, Parts, Service
 17515 IH 10 East
 Luling, TX 78648
 1-830-400-1960

Trailer Sales
 12755 IH 10 East
 Schertz, TX 78154
 1-210-648-1855

Quotation # OT - 0003927

Date: 04/12/2019

Phone: 512-398-7269

Caldwell County Unit Road
 1700 FM 2720
 Lockhart
 Tx 78644

Phone:

Fax: 512-398-1967

Dr Lic:

Trailer Description

Vin #	Body:	Color:	Year:	MFG:				
	Bottom Dump	TBD	2020	Armor Lite				
Trailer GVWR	0	Make: Armor Lite	Series: Ultra Lite		Part No	Qty	Price	Extended Price
2020 ARMOR LITE 40' ULTRA LITE BOTTOM DUMP, ELECTRIC FLIP TARP, SPRING SUSPENSION, 11R 24.5 TIRES CUT N CHIP RESISTANT, STEEL WHEELS FRONT ALUMINUM BOLT ON FENDERS, BOLT ON POLY FENDERS ON REAR					Tax			
County- Customer to Register					000	1	\$0.00	\$0.00
Randy Ballard Trailer Salesman					Tx 025	1	\$0.00	\$0.00

*(2x)
Belly Dump*

Customer Signature	Date		
State Sales Tax	\$0.00	Total Sales Price	\$63,400.00
FET	\$0.00	Tax, Title & License	\$280.00
E-Tag Fee	\$10.00	Total Quote	\$63,680.00
Registration Fee	\$0.00		
Doc Fee	\$190.00		
DOT Inspection	\$80.00		
Total TT&L	\$280.00		

Bottom/Belly Dump Trailer

PERFORMANCE TRAILER - BUDA

100 Pit Stop Trace, Buda, Texas 78610

Phone: (512) 312-5590

BUYER'S ORDER

Date Prepared: 04-12-2019		Delivery Date: 01-00-1900		Salesman: Cesar Galvez		Branch: Performance Trailer - Buda	
Purchaser: CALDWELL COUNTY				Telephone 512.227.1973 Fax:			
Mailing Address:		City:		State: TX		Zip:	
Physical Address:		City:		State: TX		Zip:	
Description: NEW 2020 MANAC BOTTOM DUMP, Unit ID # 244663							
NOTE: 2020 CPS BOTTOM DUMP TRAILER, ELE. FLIP TARP, 11R24.5 TIRES, STEEL WHEELS, SPRING SUSPENSION							
VIN: 5MC424017L3187591		Comments: TRAILER IS WHITE IN COLOR		Vocation Code:			
Purchaser's Agent: Mike		Title:		License Type: Apportioned		Account # 5122271973	

LICENSE - TITLE INFORMATION

Months: 12	Tractor:	Truck:	Trailer: X	Body Type: N/A	Color: WHI	Tons:	GCW: 80000
Apportioned: X	IMC #	Combination:	Com'l:	Token Trailer:	Gas:	Diesel: X	

INSURANCE INFORMATION

AGENCY:	
NAME:	PHONE:
LIEN INFORMATION	
NAME:	LIEN DATE:
ADDRESS:	PHONE:
CITY, STATE, ZIP:	
COMMENTS:	
AMOUNT:	NAME:

SELLING PRICE	30,700.00
ACCESSORIES	-
CASH PRICE W/ACCESS	30,700.00
TRADE IN ALLOWANCE	-
NET CASH DIFFERENCE	30,700.00
FEDERAL RETAIL EXCISE TAX	3,404.00
NET PRICE WITH F.E.T.	34,104.00
STATE SALES TAX	-
LICENSE MO. & FEE (APR)	54.25
TITLE FEE (INCLUDES \$5 TAG FEE)	38.00
COMMERCIAL INSPECTION FEE	40.00
DEALER'S INVENTORY TAX	-
DOCUMENTARY FEE*	75.00
EXTENDED WARRANTY	-
SUBTOTAL	34,311.25
BALANCE OWED ON TRADE	-
SUBTOTAL	34,311.25
PREPAYMENT	-
BALANCE DUE UPON DELIVERY	34,311.25

ADDITIONAL INFORMATION

DISCLAIMER OF WARRANTY

Any warranties on the products sold hereby are those made by the manufacturer. The seller, CLEVELAND MACK SALES, INC., PERFORMANCE TRUCK OR PERFORMANCE TRAILER, hereby expressly disclaims all warranties, either express or implied, including any implied warranty of merchantability or fitness for a particular purpose, and CLEVELAND MACK SALES INC., PERFORMANCE TRUCK OR PERFORMANCE TRAILER neither assumes nor authorizes any other person to assume for it any liability in connection with the sale of said products.

* A DOCUMENTARY FEE IS NOT AN OFFICIAL FEE. A DOCUMENTARY FEE IS NOT REQUIRED BY LAW, BUT MAY BE CHARGED TO BUYERS FOR HANDLING DOCUMENTS RELATING TO THE SALE. A DOCUMENTARY FEE MAY NOT EXCEED A REASONABLE AMOUNT AGREED TO BY THE PARTIES. THIS NOTICE IS REQUIRED BY LAW.

Vehicle(s) are subject to prior sale and will not be held more than five working days.

PURCHASER _____

THIS ORDER NOT BINDING UNTIL ACCEPTED BY DEALER.

SALESPERSON _____

ACCEPTED BY _____

Unit Road Caldwell County

From: kevin beran [REDACTED]
Sent: Friday, March 29, 2019 10:10 AM
To: unitroad@co.caldwell.tx.us
Subject: 2020-Freightliner M2-112 Day Cab Tractors-Spec & Quote
Attachments: Caldwell County-2020-M2-112 Detailed Tractor Spec..docx; Caldwell County-(2020-M2-112 Day Cab Tractor).xls

Hello Mike,

Attached are the detailed specs on the day cab tractors your considering.

FYI, if and when you decide to make the decision to move forward on the deal, putting all of the trucks and tractors on one P.O. will save you \$400.00 per truck.

With that said, the \$400.00 buy board fee is per P.O. and not per truck.

However, the trailers are different. It's a 2% fee per trailer and it's not listed as a line item, but figured into the selling price of the unit.

I will be sending the trailer specs and a quote on an email to follow!

Thank you, [REDACTED]

Kevin Beran
Freightliner of Austin
512-619-5152- Cell Phone
512-389-0000- Office- Ext.104

Tractors for Baby Amp.



FREIGHTLINER OF AUSTIN

1701 Smith Rd.
Austin, Texas 78721

Bus: 512-389-0000
Fax: 512-389-2663

INV #:

BUYER'S ORDER

BUYER'S NAME CALDWELL COUNTY		TELEPHONE 512-398-7268	
ADDRESS 110 SOUTH MAIN ST.		CITY LOCKHART	STATE TX
YEAR 2020	MAKE FREIGHTLINER	MODEL/BODY M2-112 DAY CAB TRACTOR	VIN ORDER PROPOAL
		ZIP CODE 78644	LICENSE PLATE

A DOCUMENTARY FEE IS NOT AN OFFICIAL FEE. A DOCUMENTARY FEE IS NOT REQUIRED BY LAW, BUT MAY CHARGED TO BUYER FOR HANDLING DOCUMENTS RELATING TO THE SALE. A DOCUMENTARY FEE MAY NOT EXCEED A REASONABLE AMOUNT AGREED TO BY THE PARTIES. THIS NOTICE IS REQUIRED BY LAW.

UN CARGO DOCUMENTAL NO ES UN CALGO OFFICIAL. LALEYNO EXIGEQUE SE IMPONGA UN CARGO DOCUMENTAL. PERO ESTE PODRIA COBRARSE A LOS COMPRADORES POR EL MANEJO DE LA DOCUMENTACION EN RELACION CON LE VENTA. UN CARGO DOCMENTAL NO PUEDI EXCEDER UNA CANIDAD PAZONABLE ACORDADA POR LAS PARTES. ESTA NOTIFICACION SE EXIGE POR LEY.

MILEAGE:	
SELLING PRICE	\$98,850.00
DUMP SWITCH INSTALLED IN CAB	\$500.00
BUY BOARD FEE	\$400.00

EXTENDED WARRANTY INFO. LISTED ON PAGE 16 OF THE DETAILED SPEC.

Disclaimer of Warranties
The above described vehicle sold by Freightliner of Austin is sold as is, without either express or implied warranties of any kind. Freightliner of Austin, including warranties of merchantability, fitness, and Buyer will bear the entire expense of repairing or replacing any defects that presently exist or that may occur in the future, unless a written warranty by, or service contract with, Freightliner of Austin covering the describe vehicle is delivered to Buyer in conjunction with or within 90 days following the time of purchase, but such vehicle or any of its component parts may be subject to warranty by the manufacturer thereof.

MILEAGE:				
YEAR	MAKE	MODEL/BODY	VIN	
MILEAGE:			TRADE-IN	
YEAR	MAKE	MODEL/BODY	VIN	
PAYOFF TO:		TOTAL		\$99,750.00
ADDRESS:		(Trade Allowance)		
		TRADING DIFFERENCE		
		SALES TAX		N/A
GOOD UNTIL:		DEALER'S INVENTORY TAX		N/A
QUOTED BY:		LICENSE FEE		N/A
SHOW LEIN TO:		Body Type:	DOCUMENTARY FEE	N/A
ADDRESS:		License Wt.:	FEDERAL EXCISE TAX	N/A
		State Insp.:	TOTAL SALE PRICE	\$99,750.00
DATED:		License:	PAYOFF ON TRADE	
DRAFT FOR \$		Title:	EXT. SERVICE AGREEMENT	
DRAFT THRU:		Transfer:	LESS DEPOSIT	X 2
ADDRESS:		Total Balance Due		\$199,500.00

county tax assessor-collector, is not a tax imposed on a consumer by the government, and is not required to be charged by the dealer to the buyer. The information you see on the window form for this vehicle is part of this contract. Information on the window form overrides any contrary printed information. La informacion que aparece en la ventanilla de este vehiculo forma parte de este contrato. La informacion contenida en el formulario de la ventanilla anula cualquier informacion que aparezca en el contrato de venta. If a credit purchase, this is an offer to purchase only. Buyer offers to purchase vehicle on credit term relationship is created. This order does not constitute an agreement for the extension of credit. Manufacturer/Distributor reserves the right to change the price of the vehicle in the event that the price to Seller of the new vehicle ordered hereunder is changed prior to delivery to Buyer, Buyer agrees and accepts that the cash delivered by Buyer for the trade-in is not delivered to the Seller until delivery of the new vehicle, the trade-in will be reappraised at that time and Buyer agrees to determine the allowance, if any, made for the trade-in. Buyer agrees to deliver the original bill of sale and the title to an trade-in along with the delivery of the vehicle and all documents necessary or required to transfer legal title and ownership to Seller or its assigns. Buyer warrants the trade-in to be his property and free of liens except as otherwise noted herein. Buyer further warrants that the trade-in has not been declared rebuilt salvage, reconditioned, nonrepairable, or flood damage and has not been tampered with and are in the condition as originally manufactured, except for ordinary wear, unless so disclosed. Seller makes no representations, warranties, or any information posted on the sale unit or contained in literature relating to the same reflect the results of tests performed, required or prescribed by government. It is expressly agreed to and understood by Buyer and Seller that in the event of a non-credit transaction, Seller retains a security interest in the purchase price paid for the vehicle. Buyer agrees to all the above listed charges.

BUYER'S SIGNATURE: _____ SELLER'S SIGNATURE _____ DATE _____
AUSTIN TRUCK & EQUIPMENT, LTD. DBA FREIGHTLINER OF AUSTIN

Prepared for:
Mike Cheatham
CALDWELL COUNTY
110 S MAIN ST
LOCKHART, TX 78644
Phone 512-398-7268

Prepared by:
Kevin Beran
FREIGHTLINER OF AUSTIN
1701 SMITH ROAD
AUSTIN, TX 78721
Phone 512-389-0000

A proposal for
CALDWELL COUNTY

Prepared by
FREIGHTLINER OF AUSTIN
Kevin Beran

Mar 26, 2019

Freightliner M2 112



Components shown may not reflect all spec'd options and are not to scale



Prepared for:
 Mike Cheatham
 CALDWELL COUNTY
 110 S MAIN ST
 LOCKHART, TX 78644
 Phone: 512-398-7268

Prepared by:
 Kevin Beran
 FREIGHTLINER OF AUSTIN
 1701 SMITH ROAD
 AUSTIN, TX 78721
 Phone: 512-389-0000

S P E C I F I C A T I O N P R O P O S A L

Data Code	Description	Weight Front	Weight Rear	Retail Price
Price Level				
PRL-19M	M2 PRL-19M (EFF:01/15/19)			STD
Data Version				
DRL-011	SPECPRO21 DATA RELEASE VER 011			N/C
Vehicle Configuration				
001-175	M2 112 CONVENTIONAL CHASSIS	8,244	6,026	\$146,135.00
004-220	2020 MODEL YEAR SPECIFIED			STD
002-002	SET BACK AXLE - TRACTOR	20		\$3,029.00
003-001	LH PRIMARY STEERING LOCATION			STD
General Service				
AA1-001	TRACTOR/TRAILER CONFIGURATION			N/C
AA6-002	DOMICILED, USA (EXCLUDING CALIFORNIA AND CARB OPT-IN STATES)			N/C
A85-011	CONSTRUCTION SERVICE			N/C
A84-1GM	GOVERNMENT BUSINESS SEGMENT			N/C
AA4-003	DRY BULK COMMODITY			N/C
AA5-002	TERRAIN/DUTY: 100% (ALL) OF THE TIME, IN TRANSIT, IS SPENT ON PAVED ROADS			STD
AB1-008	MAXIMUM 8% EXPECTED GRADE			STD
AB5-001	SMOOTH CONCRETE OR ASPHALT PAVEMENT - MOST SEVERE IN-TRANSIT (BETWEEN SITES) ROAD SURFACE			STD
995-1AD	FREIGHTLINER LEVEL I WARRANTY			STD
A66-99D	EXPECTED FRONT AXLE(S) LOAD : 12000.0 lbs			
A68-99D	EXPECTED REAR DRIVE AXLE(S) LOAD : 40000.0 lbs			
A63-99D	EXPECTED GROSS VEHICLE WEIGHT CAPACITY : 52000.0 lbs			
A70-99D	EXPECTED GROSS COMBINATION WEIGHT : 80000.0 lbs			
Truck Service				
AF3-2CR	TRACTOR ONLY WITH NO BODY UPFIT			N/C



Prepared for:
 Mike Cheatham
 CALDWELL COUNTY
 110 S MAIN ST
 LOCKHART, TX 78644
 Phone: 512-398-7268

Prepared by:
 Kevin Beran
 FREIGHTLINER OF AUSTIN
 1701 SMITH ROAD
 AUSTIN, TX 78721
 Phone: 512-389-0000

Data Code	Description	Weight Front	Weight Rear	Retail Price
Tractor Service				
AA2-024	BOTTOM DUMP TRAILER			N/C
AH6-001	SINGLE (1) TRAILER			N/C
Engine				
101-2YA	DETROIT DD13 12.8L 450 HP @ 1625 RPM, 1900 GOV RPM, 1650 LB/FT @ 975 RPM			\$1,174.00
Electronic Parameters				
79A-078	78 MPH ROAD SPEED LIMIT			N/C
79B-000	CRUISE CONTROL SPEED LIMIT SAME AS ROAD SPEED LIMIT			N/C
79M-002	PTO MODE BRAKE OVERRIDE - SERVICE BRAKE APPLIED OR PARK BRAKE NOT APPLIED			N/C
79N-001	PTO MODE CLUTCH OVERRIDE - CLUTCH ENABLED			N/C
79T-001	PTO MODE RPM INCREMENT - 25 RPM			N/C
79W-001	ONE REMOTE PTO SPEED			N/C
79X-005	PTO SPEED 1 SETTING - 900 RPM			N/C
80D-001	SOFT CRUISE CONTROL ENABLED			N/C
80L-003	ENABLE DPF REGEN ZONE 1 WITH AUTO ENGINE RPM ELEVATE FOR EXTENDED IDLE			N/C
Engine Equipment				
99C-017	2016 ONBOARD DIAGNOSTICS/2010 EPA/CARB/FINAL GHG17 CONFIGURATION			STD
99D-011	2008 CARB EMISSION CERTIFICATION - CLEAN IDLE (INCLUDES 6X4 INCH LABEL ON LOWER FORWARD CORNER OF DRIVER DOOR)			\$109.00
13E-001	STANDARD OIL PAN			STD
105-001	ENGINE MOUNTED OIL CHECK AND FILL			STD
133-004	ONE PIECE VALVE COVER			STD
014-099	SIDE OF HOOD AIR INTAKE WITH FIREWALL MOUNTED DONALDSON AIR CLEANER			STD
124-1D7	DR 12V 160 AMP 28-SI QUADRAMOUNT PAD ALTERNATOR WITH REMOTE BATTERY VOLT SENSE			STD
292-209	(3) DTNA GENUINE, FLOODED STARTING, MIN 3375CCA, 585RC, THREADED STUD BATTERIES			STD
290-017	BATTERY BOX FRAME MOUNTED			STD
281-001	STANDARD BATTERY JUMPERS			STD
282-003	SINGLE BATTERY BOX FRAME MOUNTED LH SIDE BACK OF CAB			STD



Prepared for:
 Mike Cheatham
 CALDWELL COUNTY
 110 S MAIN ST
 LOCKHART, TX 78644
 Phone: 512-398-7268

Prepared by:
 Kevin Beran
 FREIGHTLINER OF AUSTIN
 1701 SMITH ROAD
 AUSTIN, TX 78721
 Phone: 512-389-0000

Data Code	Description	Weight Front	Weight Rear	Retail Price
291-017	WIRE GROUND RETURN FOR BATTERY CABLES WITH ADDITIONAL FRAME GROUND RETURN			STD
289-001	NON-POLISHED BATTERY BOX COVER			STD
87P-001	CAB AUXILIARY POWER CABLE	5		N/C
295-029	POSITIVE AND NEGATIVE POSTS FOR JUMPSTART LOCATED ON FRAME NEXT TO STARTER	2		\$92.00
180-100	EATON ADVANTAGE 15-1/2 INCH SELF ADJUSTING CLUTCH			STD
183-008	TORQUE LIMITING CLUTCH BRAKE			STD
181-002	ZERK FITTING WITH EXTENSION HOSE AT CLUTCH RELEASE BEARING			STD
182-005	HYDRAULIC CLUTCH CONTROL			STD
107-044	BW MODEL BA-921 19.0 CFM SINGLE CYLINDER AIR COMPRESSOR WITH SAFETY VALVE			STD
108-002	STANDARD MECHANICAL AIR COMPRESSOR GOVERNOR			STD
131-013	AIR COMPRESSOR DISCHARGE LINE			STD
152-041	ELECTRONIC ENGINE INTEGRAL SHUTDOWN PROTECTION SYSTEM			STD
128-002	JACOBS COMPRESSION BRAKE			STD
016-1C2	RH OUTBOARD UNDER STEP MOUNTED HORIZONTAL AFTERTREATMENT SYSTEM ASSEMBLY WITH RH B-PILLAR MOUNTED VERTICAL TAILPIPE	30	25	\$823.00
28F-002	ENGINE AFTERTREATMENT DEVICE, AUTOMATIC OVER THE ROAD REGENERATION AND DASH MOUNTED REGENERATION REQUEST SWITCH			STD
239-038	11 FOOT 06 INCH (138 INCH+0/-5.9 INCH) EXHAUST SYSTEM HEIGHT			N/C
233-017	STANDARD CURVE BRIGHT UPPER STACK(S)			\$123.00
237-1CR	RH CURVED VERTICAL TAILPIPE B-PILLAR MOUNTED ROUTED FROM STEP			N/C
23U-002	13 GALLON DIESEL EXHAUST FLUID TANK	35	10	\$105.00
30N-003	100 PERCENT DIESEL EXHAUST FLUID FILL			\$17.00
23Z-002	NON-POLISHED ALUMINUM DIESEL EXHAUST FLUID TANK COVER	15	5	\$144.00
43X-002	LH MEDIUM DUTY STANDARD DIESEL EXHAUST FLUID TANK LOCATION			STD
23Y-001	STANDARD DIESEL EXHAUST FLUID PUMP MOUNTING			STD
43Y-001	STANDARD DIESEL EXHAUST FLUID TANK CAP			STD



Prepared for:
 Mike Cheatham
 CALDWELL COUNTY
 110 S MAIN ST
 LOCKHART, TX 78644
 Phone: 512-398-7268

Prepared by:
 Kevin Beran
 FREIGHTLINER OF AUSTIN
 1701 SMITH ROAD
 AUSTIN, TX 78721
 Phone: 512-389-0000

Data Code	Description	Weight Front	Weight Rear	Retail Price
242-001	STAINLESS STEEL AFTERTREATMENT DEVICE/MUFFLER/TAILOPIPE SHIELD			\$48.00
273-036	BORG WARNER (KYSOR) REAR AIR ON/OFF ENGINE FAN CLUTCH			STD
276-001	AUTOMATIC FAN CONTROL WITHOUT DASH SWITCH, NON ENGINE MOUNTED			STD
110-068	DDC SUPPLIED ENGINE MOUNTED FUEL FILTER/FUEL WATER SEPARATOR WITH WATER-IN-FUEL INDICATOR			STD
118-001	FULL FLOW OIL FILTER			STD
266-069	1400 SQUARE INCH RADIATOR			STD
103-039	ANTIFREEZE TO -34F, OAT (NITRITE AND SILICATE FREE) EXTENDED LIFE COOLANT			STD
171-007	GATES BLUE STRIPE COOLANT HOSES OR EQUIVALENT			STD
172-001	CONSTANT TENSION HOSE CLAMPS FOR COOLANT HOSES			STD
270-019	HDEP VARIABLE SPEED COOLANT PUMP AND RADIATOR DRAIN VALVE			STD
134-001	ALUMINUM FLYWHEEL HOUSING			STD
155-074	DELCO 12V MOD 3.175-39MT+ OCP STARTER WITH THERMAL PROTECTION AND INTEGRATED MAGNETIC SWITCH	-35		N/C

Transmission

342-419	EATON FULLER FRO-16210C TRANSMISSION			\$1,424.00
---------	--------------------------------------	--	--	------------

Transmission Equipment

347-002	ALUMINUM CLUTCH HOUSING			STD
341-017	MAGNETIC PLUGS, ENGINE DRAIN, TRANSMISSION FILL AND DRAIN, AXLE(S) FILL AND DRAIN			STD
345-001	PAINTED SHIFT LEVER, SOLID LINKAGE			STD
370-015	WATER TO OIL TRANSMISSION COOLER, IN RADIATOR END TANK	15		\$306.00
35T-003	SYNTHETIC TRANSMISSION LUBE			STD

Front Axle and Equipment

400-1A6	DETROIT DA-F-12-0-3 12,000# FF1 71.5 KPI/3.74 DROP SINGLE FRONT AXLE			STD
402-049	MERITOR 16.5X5 Q+ CAST SPIDER CAM FRONT BRAKES, DOUBLE ANCHOR, FABRICATED SHOES			\$214.00
403-043	2011/2013-FMVSS 121 RSD FRONT BRAKE LINING			N/C
419-023	CONMET CAST IRON FRONT BRAKE DRUMS			STD



Prepared for:
 Mike Cheatham
 CALDWELL COUNTY
 110 S MAIN ST
 LOCKHART, TX 78644
 Phone: 512-398-7268

Prepared by:
 Kevin Beran
 FREIGHTLINER OF AUSTIN
 1701 SMITH ROAD
 AUSTIN, TX 78721
 Phone: 512-389-0000

Data Code	Description	Weight Front	Weight Rear	Retail Price
409-006	FRONT OIL SEALS			STD
408-001	VENTED FRONT HUB CAPS WITH WINDOW, CENTER AND SIDE PLUGS - OIL			STD
416-022	STANDARD SPINDLE NUTS FOR ALL AXLES			STD
405-002	MERITOR AUTOMATIC FRONT SLACK ADJUSTERS			STD
536-050	TRW THP-60 POWER STEERING			STD
539-003	POWER STEERING PUMP			STD
534-015	2 QUART SEE THROUGH POWER STEERING RESERVOIR			STD
40T-002	SYNTHETIC 75W-90 FRONT AXLE LUBE			\$14.00
Front Suspension				
620-1F0	12,000# DUAL TAPERLEAF FRONT SUSPENSION	42		\$57.00
619-005	MAINTENANCE FREE RUBBER BUSHINGS - FRONT SUSPENSION			STD
410-001	FRONT SHOCK ABSORBERS			STD
Rear Axle and Equipment				
420-1K4	MT-40-14XP 40,000# R-SERIES TANDEM REAR AXLE		-30	\$319.00
421-355	3.55 REAR AXLE RATIO			N/C
424-003	IRON REAR AXLE CARRIER WITH OPTIONAL HEAVY DUTY AXLE HOUSING		30	\$101.00
386-075	MXL 18T MERITOR EXTENDED LUBE MAIN DRIVELINE WITH HALF ROUND YOKES			STD
388-073	MXL 17T MERITOR EXTENDED LUBE INTERAXLE DRIVELINE WITH HALF ROUND YOKES			STD
393-001	DRIVELINE GUARD	25	25	\$51.00
878-019	(1) INTERAXLE LOCK VALVE FOR TANDEM OR TRIDEM DRIVE AXLES			STD
87A-001	BLINKING LAMP WITH EACH INTERAXLE LOCK SWITCH, INTERAXLE UNLOCK DEFAULT WITH IGNITION OFF			STD
423-019	MERITOR 16.5X8.62 Q+ CAST SPIDER CAM REAR BRAKES, DOUBLE ANCHOR, FABRICATED SHOES		20	\$214.00
433-043	2011/2013-FMVSS 121 RSD REAR BRAKE LININGS			N/C
434-005	BRAKE CAMS AND CHAMBERS ON FORWARD SIDE OF DRIVE AXLE(S) WITH AUXILIARY SUPPORT BRACKETS			STD
451-023	CONMET CAST IRON REAR BRAKE DRUMS			STD
440-006	REAR OIL SEALS			STD



Prepared for:
 Mike Cheatham
 CALDWELL COUNTY
 110 S MAIN ST
 LOCKHART, TX 78644
 Phone: 512-398-7268

Prepared by:
 Kevin Beran
 FREIGHTLINER OF AUSTIN
 1701 SMITH ROAD
 AUSTIN, TX 78721
 Phone: 512-389-0000

Data Code	Description	Weight Front	Weight Rear	Retail Price
426-101	WABCO TRISTOP D LONGSTROKE 2-DRIVE AXLE SPRING PARKING CHAMBERS			STD
428-002	MERITOR AUTOMATIC REAR SLACK ADJUSTERS			STD
41T-002	SYNTHETIC 75W-90 REAR AXLE LUBE			N/C
Rear Suspension				
622-218	AIRLINER 40,000# EXTRA DUTY REAR SUSPENSION		160	\$475.00
621-007	AIRLINER HIGH POSITION RIDE HEIGHT			STD
431-005	RESTRAINED AXLE SEATS IN AXLE CLAMP GROUP			N/C
624-016	51 INCH AXLE SPACING			STD
888-048	MANUAL DUMP VALVE FOR AIR SUSPENSION WITH GAUGE			\$140.00
87D-006	INDICATOR LIGHT FOR EACH REAR SUSPENSION CONTROL SWITCH			N/C
910-001	SINGLE AIR REAR SUSPENSION LEVELING VALVE			STD
623-002	TRANSVERSE CONTROL RODS			STD
439-005	REAR SHOCK ABSORBERS - TWO AXLES (TANDEM) (AIR RIDE SUSPENSION)			STD
Brake System				
018-002	AIR BRAKE PACKAGE			STD
490-101	WABCO 4S/4M ABS WITH TRACTION CONTROL, WITH ATC OFF-ROAD SWITCH			\$199.00
871-001	REINFORCED NYLON, FABRIC BRAID AND WIRE BRAID CHASSIS AIR LINES			STD
904-001	FIBER BRAID PARKING BRAKE HOSE			STD
412-001	STANDARD BRAKE SYSTEM VALVES			STD
46D-002	STANDARD AIR SYSTEM PRESSURE PROTECTION SYSTEM			STD
413-002	STD U.S. FRONT BRAKE VALVE			STD
432-003	RELAY VALVE WITH 5-8 PSI CRACK PRESSURE, NO REAR PROPORTIONING VALVE			STD
480-088	WABCO SYSTEM SAVER HP WITH INTEGRAL AIR GOVERNOR AND HEATER			STD
483-004	WABCO OIL COALESCING FILTER FOR AIR DRYER			\$11.00
479-015	AIR DRYER FRAME MOUNTED			STD
460-001	STEEL AIR BRAKE RESERVOIRS			STD
607-001	CLEAR FRAME RAILS FROM BACK OF CAB TO FRONT REAR SUSPENSION BRACKET, BOTH RAILS OUTBOARD			\$63.00



Prepared for:
 Mike Cheatham
 CALDWELL COUNTY
 110 S MAIN ST
 LOCKHART, TX 78644
 Phone: 512-398-7268

Prepared by:
 Kevin Beran
 FREIGHTLINER OF AUSTIN
 1701 SMITH ROAD
 AUSTIN, TX 78721
 Phone: 512-389-0000

Data Code	Description	Weight Front	Weight Rear	Retail Price
477-004	PULL CABLES ON ALL AIR RESERVOIR(S)			\$3.00
Trailer Connections				
481-074	15 FOOT COILED TRAILER AIR HOSE WITH 48 INCH TRACTOR, 12 INCH TRAILER LEADS	12		\$42.00
476-057	36 INCH STAINLESS STEEL SLIDE BAR WITH (2) 16 INCH SPRING TYPE AIR HOSE HANGERS	2		\$38.00
484-006	COMBINATION DUMMY GLAD HANDS AND LIGHT PLUG HOLDER			N/C
296-010	PRIMARY CONNECTOR/RECEPTACLE WIRED FOR SEPARATE STOP/TURN, ABS CENTER PIN POWERED THROUGH IGNITION			N/C
297-008	SAE J560 7-WAY PRIMARY TRAILER CABLE RECEPTACLE BRACKET LH LOWER CAB MOUNTED			N/C
335-004	UPGRADED CHASSIS MULTIPLEXING UNIT			STD
32A-002	UPGRADED BULKHEAD MULTIPLEXING UNIT			STD
310-085	15 FOOT DETACHABLE COILED PRIMARY TRAILER ELECTRICAL CABLE WITH SAE J560 CONNECTOR WITH 48 INCH TRACTOR, 12 INCH TRAILER LEADS	12		\$30.00
Wheelbase & Frame				
545-495	4950MM (195 INCH) WHEELBASE			N/C
546-100	1 1/32X3-1/2X10-3/16 INCH STEEL FRAME (8.73MMX258.8MM/0.344X10.19 INCH) 120KSI	40		\$417.00
552-012	1450MM (57 INCH) REAR FRAME OVERHANG			N/C
55W-005	FRAME OVERHANG RANGE: 51 INCH TO 60 INCH	10	-40	N/C
AC8-99D	CALC'D BACK OF CAB TO REAR SUSP C/L (CA) : 129.35 in			
AE8-99D	CALCULATED EFFECTIVE BACK OF CAB TO REAR SUSPENSION C/L (CA) : 114.58 in			
AE4-99D	CALC'D FRAME LENGTH - OVERALL : 282.11			
FSS-0LH	CALCULATED FRAME SPACE LH SIDE : 32.74 in			N/C
FSS-0RH	CALCULATED FRAME SPACE RH SIDE : 19.01 in			N/C
AM6-99D	CALC'D SPACE AVAILABLE FOR DECKPLATE : 92.08 in			
553-002	FLANGED TAPERED END OF FRAME			N/C
550-001	FRONT CLOSING CROSSMEMBER			STD
559-001	STANDARD WEIGHT ENGINE CROSSMEMBER			STD
561-001	STANDARD CROSSMEMBER BACK OF TRANSMISSION			STD
562-001	STANDARD MIDSHIP #1 CROSSMEMBER(S)			STD
572-001	STANDARD REARMOST CROSSMEMBER			STD



Prepared for:
 Mike Cheatham
 CALDWELL COUNTY
 110 S MAIN ST
 LOCKHART, TX 78644
 Phone: 512-398-7268

Prepared by:
 Kevin Beran
 FREIGHTLINER OF AUSTIN
 1701 SMITH ROAD
 AUSTIN, TX 78721
 Phone: 512-389-0000

Data Code	Description	Weight Front	Weight Rear	Retail Price
565-002	HEAVY DUTY SUSPENSION CROSSMEMBER		30	N/C
Chassis Equipment				
674-002	LH AND RH BACK OF CAB ACCESS	10	10	\$123.00
592-055	28 INCH (700MM) DECK PLATE FLUSH MOUNTED BETWEEN RAILS	10	10	\$106.00
556-1AP	THREE-PIECE 14 INCH PAINTED STEEL BUMPER WITH COLLAPSIBLE ENDS			STD
574-001	BUMPER MOUNTING FOR SINGLE LICENSE PLATE			STD
585-1AR	BETTS B-60NT PAINTED MUDFLAP BRACKETS WITH NO TAPE		25	\$35.00
590-004	SYMLASTICS SPRAY GUARD BLACK MUDFLAPS, NO LOGO		15	\$32.00
586-024	FENDER AND FRONT OF HOOD MOUNTED FRONT MUDFLAPS			STD
551-007	GRADE 8 THREADED HEX HEADED FRAME FASTENERS			STD
583-059	PLASTIC QUARTER FENDERS WITH LOGO		30	\$113.00
Fifth Wheel				
578-1U6	JOST JSK36 SERIES 24.0 INCH AIR SLIDE FIFTH WHEEL WITH FABRICATED TOP PLATE - 2 INCH SLIDE INCREMENTS	30	490	N/C
577-305	FIFTH WHEEL 305MM (12.0 INCHES) AHEAD OF SUSPENSION CENTERLINE			N/C
582-014	197MM (7.75 INCH) FIFTH WHEEL HEIGHT			N/C
570-001	OUTBOARD ANGLE - FIFTH WHEEL MOUNTING			N/C
890-001	DASH MOUNTED CONTROL VALVE AND PLUMBING FOR FIFTH WHEEL			N/C
579-005	LH FIFTH WHEEL RELEASE			N/C
Fuel Tanks				
206-155	90 GALLON/340 LITER ALUMINUM FUEL TANK - RH	100	20	\$1,060.00
204-155	90 GALLON/340 LITER ALUMINUM FUEL TANK - LH	15		\$208.00
218-006	25 INCH DIAMETER FUEL TANK(S)			STD
215-005	PLAIN ALUMINUM/PAINTED STEEL FUEL/HYDRAULIC TANK(S) WITH PAINTED BANDS			STD
212-014	LH FUEL TANK MOUNTED FORWARD, RH FUEL TANK MOUNTED AFT	-35	35	N/C
664-001	PLAIN STEP FINISH			STD
205-001	FUEL TANK CAP(S)			STD



Prepared for:
 Mike Cheatham
 CALDWELL COUNTY
 110 S MAIN ST
 LOCKHART, TX 78644
 Phone: 512-398-7268

Prepared by:
 Kevin Beran
 FREIGHTLINER OF AUSTIN
 1701 SMITH ROAD
 AUSTIN, TX 78721
 Phone: 512-389-0000

Data Code	Description	Weight Front	Weight Rear	Retail Price
216-020	EQUIFLO INBOARD FUEL SYSTEM			STD
11F-998	NO NATURAL GAS VEHICLE FUEL TANK VENT LINE/STACK			STD
202-016	HIGH TEMPERATURE REINFORCED NYLON FUEL LINE			STD
Tires				
093-1AX	MICHELIN XZE2 11R22.5 16 PLY RADIAL FRONT TIRES	24		(\$38.00)
094-1UY	MICHELIN X MULTI D 11R22.5 16 PLY RADIAL REAR TIRES (NORTH AMERICAN ONLY)		120	(\$80.00)
Hubs				
418-060	CONMET PRESET PLUS PREMIUM IRON FRONT HUBS			STD
450-060	CONMET PRESET PLUS PREMIUM IRON REAR HUBS			STD
Wheels				
502-524	MAXION WHEELS 90541 22.5X8.25 10-HUB PILOT 6.20 INSET 2-HAND STEEL DISC FRONT WHEELS			N/C
505-524	MAXION WHEELS 90541 22.5X8.25 10-HUB PILOT 2-HAND STEEL DISC REAR WHEELS			N/C
496-011	FRONT WHEEL MOUNTING NUTS			STD
497-011	REAR WHEEL MOUNTING NUTS			STD
Cab Exterior				
829-072	112 INCH BBC FLAT ROOF ALUMINUM CONVENTIONAL CAB			STD
650-008	AIR CAB MOUNTING			STD
705-012	CAB ROOF REINFORCEMENTS FOR ROOF MOUNTED COMPONENTS	2		\$63.00
648-002	NONREMOVABLE BUGSCREEN MOUNTED BEHIND GRILLE			\$36.00
678-001	LH AND RH GRAB HANDLES			STD
646-023	HOOD MOUNTED CHROMED PLASTIC GRILLE			\$270.00
65X-003	CHROME HOOD MOUNTED AIR INTAKE GRILLE			\$49.00
644-004	FIBERGLASS HOOD			STD
690-002	TUNNEL/FIREWALL LINER			\$35.00
727-066	DUAL 26 INCH RECTANGULAR POLISHED ALUMINUM AIR HORNS ROOF MOUNTED	8		\$185.00
726-001	SINGLE ELECTRIC HORN			STD
728-002	DUAL HORN SHIELDS			N/C



Prepared for:
 Mike Cheatham
 CALDWELL COUNTY
 110 S MAIN ST
 LOCKHART, TX 78644
 Phone: 512-398-7268

Prepared by:
 Kevin Beran
 FREIGHTLINER OF AUSTIN
 1701 SMITH ROAD
 AUSTIN, TX 78721
 Phone: 512-389-0000

Data Code	Description	Weight Front	Weight Rear	Retail Price
657-001	DOOR LOCKS AND IGNITION SWITCH KEYED THE SAME			STD
575-001	REAR LICENSE PLATE MOUNT END OF FRAME			STD
312-038	INTEGRAL HEADLIGHT/MARKER ASSEMBLY WITH CHROME BEZEL			N/C
302-047	LED AERODYNAMIC MARKER LIGHTS			\$34.00
311-001	DAYTIME RUNNING LIGHTS			\$18.00
294-042	FREIGHTLINER LED FLANGE MOUNTED STOP/TAIL/TURN LIGHTS WITH SEPARATE INCANDESCENT BACKUP LIGHTS		5	\$107.00
300-015	STANDARD FRONT TURN SIGNAL LAMPS			STD
318-1F6	(1) FLUSH LED UTILITY LIGHT MOUNTED LH BACK OF CAB/SLEEPER	3		\$75.00
744-1BN	DUAL WEST COAST BRIGHT FINISH MIRRORS			\$83.00
797-001	DOOR MOUNTED MIRRORS			STD
796-001	102 INCH EQUIPMENT WIDTH			STD
743-204	LH AND RH 8 INCH BRIGHT FINISH CONVEX MIRRORS MOUNTED UNDER PRIMARY MIRRORS			N/C
74A-001	RH DOWN VIEW MIRROR			\$24.00
729-001	STANDARD SIDE/REAR REFLECTORS			STD
73A-002	REAR REFLECTIVE DEVICE			N/C
677-054	RH AFTERTREATMENT SYSTEM CAB ACCESS WITH PLAIN DIAMOND PLATE COVER			(\$3.00)
764-010	COMPOSITE EXTERIOR SUN VISOR	10		\$280.00
768-043	63X14 INCH TINTED REAR WINDOW			STD
661-003	TINTED DOOR GLASS LH AND RH WITH TINTED NON-OPERATING WING WINDOWS			STD
654-003	MANUAL DOOR WINDOW REGULATORS			STD
663-013	TINTED WINDSHIELD			STD
659-019	2 GALLON WINDSHIELD WASHER RESERVOIR WITHOUT FLUID LEVEL INDICATOR, FRAME MOUNTED			STD

Cab Interior

707-1AK	OPAL GRAY VINYL INTERIOR			N/C
706-013	MOLDED PLASTIC DOOR PANEL			STD
708-013	MOLDED PLASTIC DOOR PANEL			STD
772-006	BLACK MATS WITH SINGLE INSULATION			STD
785-001	DASH MOUNTED ASH TRAYS AND LIGHTER			STD
691-008	FORWARD ROOF MOUNTED CONSOLE WITH UPPER STORAGE COMPARTMENTS WITHOUT NETTING			STD



Prepared for:
 Mike Cheatham
 CALDWELL COUNTY
 110 S MAIN ST
 LOCKHART, TX 78644
 Phone: 512-398-7268

Prepared by:
 Kevin Beran
 FREIGHTLINER OF AUSTIN
 1701 SMITH ROAD
 AUSTIN, TX 78721
 Phone: 512-389-0000

Data Code	Description	Weight Front	Weight Rear	Retail Price
696-012	CENTER STORAGE CONSOLE MOUNTED ON BACKWALL	20		\$26.00
742-007	(2) CUP HOLDERS LH AND RH DASH			STD
680-007	GRAY/CHARCOAL WING DASH			STD
720-003	5 LB. FIRE EXTINGUISHER	10		\$60.00
700-002	HEATER, DEFROSTER AND AIR CONDITIONER			STD
701-001	STANDARD HVAC DUCTING			STD
703-005	MAIN HVAC CONTROLS WITH RECIRCULATION SWITCH			STD
170-015	STANDARD HEATER PLUMBING			STD
130-041	VALEO HEAVY DUTY A/C REFRIGERANT COMPRESSOR			STD
702-002	BINARY CONTROL, R-134A			STD
739-033	STANDARD INSULATION			STD
285-027	SOLID-STATE CIRCUIT PROTECTION AND FUSES WITH SPARE FUSE KIT			\$33.00
280-007	12V NEGATIVE GROUND ELECTRICAL SYSTEM			STD
324-011	DOMED DOOR ACTIVATED LH AND RH, DUAL READING LIGHTS, FORWARD CAB ROOF			\$59.00
655-001	CAB DOOR LATCHES WITH MANUAL DOOR LOCKS			STD
284-023	(1) 12 VOLT POWER SUPPLY IN DASH			\$21.00
722-028	TRIANGULAR REFLECTORS KIT WITHOUT FLARES SHIPPED LOOSE IN CAB	10		\$24.00
756-1J3	BASIC HIGH BACK AIR SUSPENSION DRIVER SEAT WITH MECHANICAL LUMBAR AND INTEGRATED CUSHION EXTENSION	30		\$212.00
760-1DC	BASIC HIGH BACK NON SUSPENSION PASSENGER SEAT			STD
759-007	DUAL DRIVER SEAT ARMRESTS, NO PASSENGER SEAT ARMRESTS	4		\$69.00
711-004	LH AND RH INTEGRAL DOOR PANEL ARMRESTS			STD
758-036	VINYL WITH VINYL INSERT DRIVER SEAT			STD
761-036	VINYL WITH VINYL INSERT PASSENGER SEAT			STD
763-101	BLACK SEAT BELTS			STD
532-001	FIXED STEERING COLUMN			STD
540-016	18 INCH (450MM) LEATHER WRAPPED STEERING WHEEL			\$102.00
765-002	DRIVER AND PASSENGER INTERIOR SUN VISORS			STD

Instruments & Controls

732-004	GRAY DRIVER INSTRUMENT PANEL			STD
---------	------------------------------	--	--	-----



Prepared for:
 Mike Cheatham
 CALDWELL COUNTY
 110 S MAIN ST
 LOCKHART, TX 78644
 Phone: 512-398-7268

Prepared by:
 Kevin Beran
 FREIGHTLINER OF AUSTIN
 1701 SMITH ROAD
 AUSTIN, TX 78721
 Phone: 512-389-0000

Data Code	Description	Weight Front	Weight Rear	Retail Price
734-004	GRAY CENTER INSTRUMENT PANEL			STD
870-001	BLACK GAUGE BEZELS			STD
486-001	LOW AIR PRESSURE INDICATOR LIGHT AND AUDIBLE ALARM			STD
838-001	(1) SINGLE BRAKE APPLICATION AIR GAUGE			\$72.00
840-002	2 INCH PRIMARY AND SECONDARY AIR PRESSURE GAUGES			STD
198-003	DASH MOUNTED AIR RESTRICTION INDICATOR WITH GRADUATIONS			\$36.00
721-001	97 DB BACKUP ALARM		3	\$44.00
149-017	ELECTRONIC CRUISE CONTROL WITH SWITCHES ON AUXILIARY GAUGE PANEL (B DASH PANEL)			STD
156-007	KEY OPERATED IGNITION SWITCH AND INTEGRAL START POSITION; 4 POSITION OFF/RUN/START/ACCESSORY			STD
811-042	ICU3S, 132X48 DISPLAY WITH DIAGNOSTICS, 28 LED WARNING LAMPS AND DATA LINKED			STD
160-038	HEAVY DUTY ONBOARD DIAGNOSTICS INTERFACE CONNECTOR LOCATED BELOW LH DASH			STD
844-001	2 INCH ELECTRIC FUEL GAUGE			STD
845-011	FUEL FILTER RESTRICTION INDICATOR			STD
148-085	EMISSIONS LIMITED IDLE ADJUST			STD
856-001	ELECTRICAL ENGINE COOLANT TEMPERATURE GAUGE			STD
864-001	2 INCH TRANSMISSION OIL TEMPERATURE GAUGE			\$22.00
830-017	ENGINE AND TRIP HOUR METERS INTEGRAL WITHIN DRIVER DISPLAY			STD
49B-004	ELECTRONIC STABILITY CONTROL			\$1,134.00
852-002	ELECTRIC ENGINE OIL PRESSURE GAUGE			STD
679-001	OVERHEAD INSTRUMENT PANEL			\$76.00
746-114	AM/FM/WB WORLD TUNER RADIO WITH AUXILIARY INPUT, J1939	10		\$290.00
747-001	DASH MOUNTED RADIO			N/C
750-002	(2) RADIO SPEAKERS IN CAB			N/C
753-001	AM/FM ANTENNA MOUNTED ON FORWARD LH ROOF			N/C
748-006	POWER AND GROUND WIRING PROVISION OVERHEAD			\$23.00
749-016	CB WIRING ONLY TO ROOF/OVERHEAD CONSOLE; NO MOUNTING PROVISION			\$38.00



Prepared for:
 Mike Cheatham
 CALDWELL COUNTY
 110 S MAIN ST
 LOCKHART, TX 78644
 Phone: 512-398-7268

Prepared by:
 Kevin Beran
 FREIGHTLINER OF AUSTIN
 1701 SMITH ROAD
 AUSTIN, TX 78721
 Phone: 512-389-0000

Data Code	Description	Weight Front	Weight Rear	Retail Price
810-027	ELECTRONIC MPH SPEEDOMETER WITH SECONDARY KPH SCALE, WITHOUT ODOMETER			STD
817-001	STANDARD VEHICLE SPEED SENSOR			STD
812-001	ELECTRONIC 3000 RPM TACHOMETER			STD
813-1B4	VT-HU CONNECTIVITY PLATFORM HARDWARE			STD
8D1-002	2 YEARS DETROIT CONNECT BASE PACKAGE (VIRTUAL TECHNICIAN, DETROIT CONNECT PORTAL ACCESS) FOR VT-HU CONNECTIVITY PLATFORM			STD
162-002	IGNITION SWITCH CONTROLLED ENGINE STOP			STD
329-015	ONE ON/OFF ROCKER SWITCH IN THE DASH WITH INDICATOR LIGHT AND WIRE ROUTED TO CHASSIS AT BACK OF CAB, LABEL OPT			\$33.00
81Y-001	PRE-TRIP LAMP INSPECTION, ALL OUTPUTS FLASH, WITH SMART SWITCH			\$12.00
482-001	BW TRACTOR PROTECTION VALVE			N/C
883-001	TRAILER HAND CONTROL BRAKE VALVE			N/C
836-015	DIGITAL VOLTAGE DISPLAY INTEGRAL WITH DRIVER DISPLAY			STD
660-008	SINGLE ELECTRIC WINDSHIELD WIPER MOTOR WITH DELAY			STD
304-001	MARKER LIGHT SWITCH INTEGRAL WITH HEADLIGHT SWITCH			STD
882-004	TWO VALVE PARKING BRAKE SYSTEM WITH WARNING INDICATOR			N/C
299-013	SELF CANCELING TURN SIGNAL SWITCH WITH DIMMER, WASHER/WIPER AND HAZARD IN HANDLE			STD
298-039	INTEGRAL ELECTRONIC TURN SIGNAL FLASHER WITH HAZARD LAMPS OVERRIDING STOP LAMPS			STD
Design				
065-000	PAINT: ONE SOLID COLOR			STD
Color				
980-5F6	CAB COLOR A: L0006EB WHITE ELITE BC			STD
986-020	BLACK, HIGH SOLIDS POLYURETHANE CHASSIS PAINT			STD
962-972	POWDER WHITE (N0006EA) FRONT WHEELS/RIMS (PKWHT21, TKWHT21, W, TW)			STD
966-972	POWDER WHITE (N0006EA) REAR WHEELS/RIMS (PKWHT21, TKWHT21, W, TW)			STD
964-6Z7	BUMPER PAINT: FP24812 ARGENT SILVER DUPONT FLEX			STD



Prepared for:
 Mike Cheatham
 CALDWELL COUNTY
 110 S MAIN ST
 LOCKHART, TX 78644
 Phone: 512-398-7268

Prepared by:
 Kevin Beran
 FREIGHTLINER OF AUSTIN
 1701 SMITH ROAD
 AUSTIN, TX 78721
 Phone: 512-389-0000

Data Code	Description	Weight Front	Weight Rear	Retail Price
976-995	SUNVISOR PAINTED SAME AS CAB COLOR A			N/C
963-003	STANDARD E COAT/UNDERCOATING			STD

Certification / Compliance

996-001	U.S. FMVSS CERTIFICATION, EXCEPT SALES CABS AND GLIDER KITS			STD
---------	-------------------------------------------------------------	--	--	-----

Secondary Factory Options

998-001	CORPORATE PDI CENTER IN-SERVICE ONLY			N/C
---------	--------------------------------------	--	--	-----

Raw Performance Data

AE4-99D	CALC'D FRAME LENGTH - OVERALL : 282.11
AE8-99D	CALCULATED EFFECTIVE BACK OF CAB TO REAR SUSPENSION C/L (CA) : 114.58 in
AM6-99D	CALC'D SPACE AVAILABLE FOR DECKPLATE : 92.08 in

Sales Programs

NO SALES PROGRAMS HAVE BEEN SELECTED

TOTAL VEHICLE SUMMARY

Adjusted List Price

Adjusted List Price ** \$161,118.00

Weight Summary

	Weight Front	Weight Rear	Total Weight
Factory Weight*	8735 lbs	7024 lbs	15759 lbs
Total Weight*	8735 lbs	7024 lbs	15759 lbs

ITEMS NOT INCLUDED IN ADJUSTED LIST PRICE

Other Factory Charges



Prepared for:
 Mike Cheatham
 CALDWELL COUNTY
 110 S MAIN ST
 LOCKHART, TX 78644
 Phone: 512-398-7268

Prepared by:
 Kevin Beran
 FREIGHTLINER OF AUSTIN
 1701 SMITH ROAD
 AUSTIN, TX 78721
 Phone: 512-389-0000

RD1-002	2 YEARS DETROIT CONNECT BASE PACKAGE (VIRTUAL TECHNICIAN, DETROIT CONNECT PORTAL ACCESS)	STD
P73-2FT	STANDARD DESTINATION CHARGE	\$2,100.00

Extended Warranty

WAI-10V	EW4: DD13 VOC \$0 DED 5 YEARS/200,000 MILES/322,000 KM FEX APPLIES	\$2,900.00
WAG-011	TOWING: 2 YEARS/UNLIMITED MILES/KM EXTENDED TOWING COVERAGE \$550 CAP FEX APPLIES	\$400.00
	Currency Exchange Rate	1.0000
	Total Extended Warranty (Local Currency)	\$3,300.00

(+) Weights shown are estimates only.

If weight is critical, contact Customer Application Engineering.

(**) Prices shown do not include taxes, fees, etc... "Net Equipment Selling Price" is located on the Quotation Details Proposal Report.



Prepared for:
 Mike Cheatham
 CALDWELL COUNTY
 110 S MAIN ST
 LOCKHART, TX 78644
 Phone 512-398-7268

Prepared by:
 Kevin Beran
 FREIGHTLINER OF AUSTIN
 1701 SMITH ROAD
 AUSTIN, TX 78721
 Phone: 512-389-0000

D I M E N S I O N S

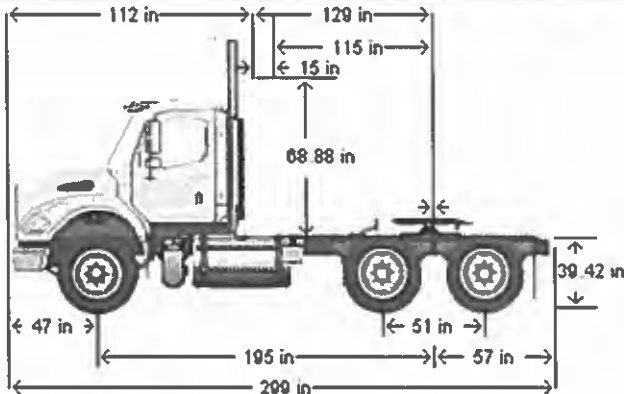

VEHICLE SPECIFICATIONS SUMMARY - DIMENSIONS

Model	M2112
Wheelbase (545)	4950MM (195 INCH) WHEELBASE
Rear Frame Overhang (552)	1450MM (57 INCH) REAR FRAME OVERHANG
Fifth Wheel (578)	JOST JSK36 SERIES 24.0 INCH AIR SLIDE FIFTH WHEEL WITH FABRICATED TOP PLATE - 2 INCH SLIDE INCREMENTS
Mounting Location (577)	FIFTH WHEEL 305MM (12.0 INCHES) AHEAD OF SUSPENSION CENTERLINE
Maximum Forward Position (in)	12
Maximum Rearward Position (in)	-12
Amount of Slide Travel (in)	24
Slide Increment (in)	2
Desired Slide Position (in)	0.0
Cab Size (829)	112 INCH BBC FLAT ROOF ALUMINUM CONVENTIONAL CAB
Sleeper (682)	NO SLEEPER BOX/SLEEPER CAB
Exhaust System (016)	RH OUTBOARD UNDER STEP MOUNTED HORIZONTAL AFTERTREATMENT SYSTEM ASSEMBLY WITH RH B-PILLAR MOUNTED VERTICAL TAILPIPE

TABLE SUMMARY - DIMENSIONS



Prepared for:
 Mike Cheatham
 CALDWELL COUNTY
 110 S MAIN ST
 LOCKHART, TX 78644
 Phone: 512-398-7268

Prepared by:
 Kevin Beran
 FREIGHTLINER OF AUSTIN
 1701 SMITH ROAD
 AUSTIN, TX 78721
 Phone: 512-389-0000

Dimensions	Inches
Bumper to Back of Cab (BBC)	112.4
Bumper to Centerline of Front Axle (BA)	46.9
Back of Cab to Centerline of Rear Axle(s) (CA)	129.3
Effective Back of Cab to Centerline of Rear Axle(s) (Effective CA)	114.6
Back of Cab Protrusions (Exhaust/Intake) (CP)	14.8
Back of Cab Protrusions (Side Extenders/Trim Tab) (CP)	0.0
Back of Cab Protrusions (CNG Tank)	0.0
Back of Cab Clearance (CL)	14.8
Back of Cab to End of Frame	186.4
Cab Height (CH)	68.9
Fifth Wheel to Centerline of Rear Axle(s) (FW)	0.0
Wheelbase (WB)	194.9
Frame Overhang (OH)	57.0
Overall Length (OAL)	298.8
Rear Axle Spacing	51.0
Unladen Frame Height at Centerline of Rear Axle	39.4

Performance calculations are estimates only. If performance calculations are critical, please contact Customer Application Engineering.



Prepared for:
 Mike Cheatham
 CALDWELL COUNTY
 110 S MAIN ST
 LOCKHART, TX 78644
 Phone: 512-398-7268

Prepared by:
 Kevin Beran
 FREIGHTLINER OF AUSTIN
 1701 SMITH ROAD
 AUSTIN, TX 78721
 Phone: 512-389-0000

OPERATING RANGE

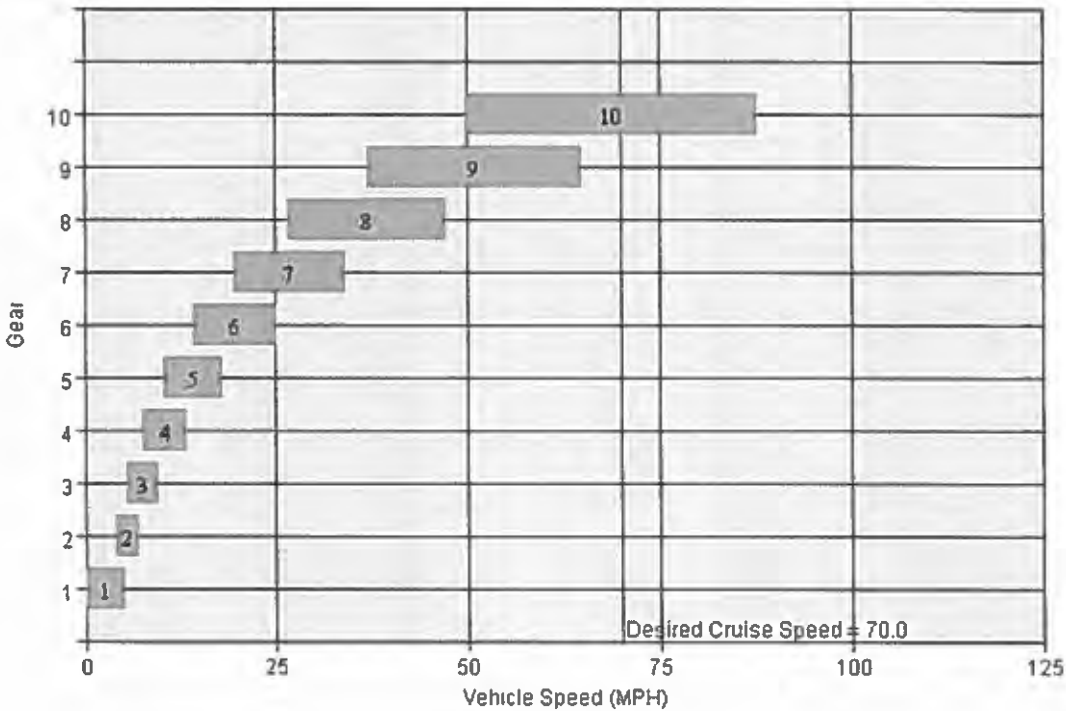

VEHICLE SPECIFICATIONS SUMMARY - OPERATING RANGE

Model M2112
 Cab Size (829)..... 112 INCH BBC FLAT ROOF ALUMINUM CONVENTIONAL CAB
 Desired Cruise Speed (mph)..... 70.0
 Engine (101)..... DETROIT DD13 12.8L 450 HP @ 1625 RPM, 1900 GOV RPM, 1650 LB/FT @ 975 RPM
 RPM at Peak Torque 1075
 Governed RPM 1900
 Transmission (342)..... EATON FULLER FRO-16210C TRANSMISSION
 Gear Ratio: LL N/A
 Gear Ratio: L N/A



Prepared for:
 Mike Cheatham
 CALDWELL COUNTY
 110 S MAIN ST
 LOCKHART TX 78644
 Phone: 512-398-7268

Prepared by:
 Kevin Beran
 FREIGHTLINER OF AUSTIN
 1701 SMITH ROAD
 AUSTIN, TX 78721
 Phone: 512-389-0000

Gear Ratio: 1	12.69
Gear Ratio: 2	9.29
Gear Ratio: 3	6.75
Gear Ratio: 4	4.9
Gear Ratio: 5	3.62
Gear Ratio: 6	2.59
Gear Ratio: 7	1.9
Gear Ratio: 8	1.38
Gear Ratio: 9	1
Gear Ratio: 10	0.74
Gear Ratio: 11	N/A
Gear Ratio: 12	N/A
Gear Ratio: 13	N/A
Gear Ratio: 14	N/A
Gear Ratio: 15	N/A
Gear Ratio: 16	N/A
Gear Ratio: 17	N/A
Gear Ratio: 18	N/A
Auxiliary Transmission (352)	NO AUXILIARY TRANSMISSION
Low Gear Ratio	N/A
High Gear Ratio	N/A
Transfer Case (373)	NO TRANSFER CASE
Low Gear Ratio	N/A
High Gear Ratio	N/A
Rear Axle (420)	MT-40-14XP 40,000# R-SERIES TANDEM REAR AXLE
Number of Speeds	1
Rear Axle Gear Ratio(s)	3.55 REAR AXLE RATIO
Rear Tires (094)	MICHELIN X MULTI D 11R22.5 16 PLY RADIAL REAR TIRES (NORTH AMERICAN ONLY)
Revolutions per Mile	494

TABLE SUMMARY - OPERATING RANGE

Transmission Gear	Transmission Gear Ratio	Rear Axle Ratio	Overall Gear Ratio	Minimum Speed (MPH)	Maximum Speed (MPH)
1	12.69	3.55	45.05	0	5.1
2	9.29	3.55	32.98	4.0	7.0
3	6.75	3.55	23.96	5.4	9.6
4	4.90	3.55	17.39	7.5	13.3
5	3.62	3.55	12.85	10.2	18.0
6	2.59	3.55	9.19	14.2	25.1
7	1.90	3.55	6.74	19.4	34.2
8	1.38	3.55	4.90	26.7	47.1
9	1.00	3.55	3.55	36.8	65.0
10	0.74	3.55	2.63	49.7	87.8



Prepared for:
Mike Cheatham
CALDWELL COUNTY
110 S MAIN ST
LOCKHART, TX 78644
Phone: 512-398-7268

Prepared by:
Kevin Beran
FREIGHTLINER OF AUSTIN
1701 SMITH ROAD
AUSTIN, TX 78721
Phone: 512-389-0000

Performance calculations are estimates only. If performance calculations are critical, please contact Customer Application Engineering.





Heavy Truck
same as Beley dumps.

Vanguard Truck Center of Austin
18001 N. HWY 35, Buda, TX 78610
Ph (512) 312-5400 Fax (512) 312-5440

*Tractor's
for Beley
Dump*

New Vehicle Quotation Form

4/1/2019

(DATE)

CALDWELL COUNTY UNIT ROAD SYSTEMS

(PURCHASER)

1700 FM 2720

(ADDRESS)

LOCKHART, TX 78644

(CITY, STATE, ZIP)

DONALD LeCLERC

(Contact)

(512) 398-7269

(Telephone)

(Fax)

2020 MACK PI64T

Sales Price	\$	<u>110,534.18</u>
Federal Retail Excise Tax	\$	<u>0.00</u>
Net Trade Allowance	(\$)	<u>0.00</u>)
Sales Tax (Includes Emission Surcharge)	\$	<u>0.00</u>
Ad Valorem Tax	\$	<u>0.00</u>
License Fee: Type <u>STATE</u> Wt. <u>0</u>	\$	<u>0.00</u>
Total Price	\$	<u>110,534.18</u>
Total Del. Price for <u>1</u> Vehicles	\$	<u>110,534.18</u>

VIN #	<u>1M1PN4GYXLM003665</u>
Engine	<u>MACK MP8 505HP</u>
Transmission	<u>MACK M-DRIVE 12-SPEED</u>
Fr. Axle	<u>MACK 12,000LB</u>
Rr. Axle	<u>MERITOR 40,000LB</u>
Suspension	<u>MACK AIR RIDE</u>
Ratio	<u>3.08</u>
Wheelbase	<u>213"</u>
Color	<u>WHITE</u>

Additional Comments:



Thank you for allowing me to quote your trucking needs!
JOHN WALSH



Vanguard Truck Center of Austin

NEW VEHICLE PURCHASE ORDER

4/1/2019

(DATE)

CALDWELL COUNTY UNIT ROAD SYSTEMS

(PURCHASER)

1700 FM 2720

(ADDRESS)

LOCKHART, TX 78644

(CITY, STATE, ZIP)

Telephone(s) (512) 398-7269

Fax Number _____

The undersigned Purchaser hereby orders from Vanguard Truck Center of Austin (hereinafter call the "Company")

1 New vehicle(s), Make MACK Model PI64T Year 2020 as described in the attached Specifications Covering Order for New Chassis VIN No. 1M1PN4GYXLM003665. Said vehicle(s) are to be delivered on or about _____ according to the following terms and conditions:

This order is Subject to the Price in Effect at the Time of Delivery. See Third to last Paragraph on Reverse Side Hereof:

Price per Vehicle	\$	<u>110,534.18</u>
Misc. Charges Des. _____	\$	<u>0.00</u>
Federal Retail Excise Tax	\$	<u>0.00</u>
Net Trade Allowance	(\$	<u>0.00)</u>
Sales Tax (Includes Emission Surcharge)	\$	<u>0.00</u>
Ad Valorem Tax	\$	<u>0.00</u>
Lic. Fee Type <u>TATE ISSUE</u> Wt. <u>0</u>	\$	<u>0.00</u>
Total Price	\$	<u>110,534.18</u>
Total Price for <u>1</u> Vehicles	\$	<u>110,534.18</u>
Less Total Prepayment	\$	<u>0.00</u>
Balance of Purchase Price	\$	<u>110,534.18</u>

Trade Calculations	
Trade Value	\$ <u>0.00</u>
Trade Payoff	\$ <u>0.00</u>
Net Trade Allowance	\$ <u>0.00</u>
Description of Trade	
Year: _____	Make _____ Model _____
Vin#: _____	<u>0</u>
Mileage: _____	<u>0</u>

THE COMPANY MAKES NO WARRANTIES AS TO SAID VEHICLE(S), EXPRESS, IMPLIED OR IMPLIED BY LAW. EXCEPT THE MANUFACTURER'S STANDARD VEHICLE WARRANTY, A COPY OF WHICH HAS BEEN DELIVERED TO THE PURCHASER, WHICH IS NOT INCORPORATED HEREIN BY REFERENCE. THE COMPANY SPECIFICALLY DISCLAIMS ANY IMPLIED WARRANTY OF MERCHANTABILITY OR FITNESS FOR A PARTICULAR PURPOSE. THE COMPANY SHALL NOT BE LIABLE FOR CONSEQUENTIAL DAMAGES, INCLUDING, BUT NOT LIMITED TO, LOSS OF INCOME. THE TERMS AND CONDITIONS ON THE REVERSE SIDE HEREOF ARE A PART OF THIS AGREEMENT. THE PURCHASER ACKNOWLEDGES HAVING READ THIS AGREEMENT, INCLUDING SUCH TERMS AND CONDITIONS. ALL VEHICLES ARE SUBJECT TO PRIOR SALES. NO VEHICLES ARE HELD MORE THAN 5 DAYS WAITING FOR CREDIT APPROVAL.

Date _____ 20 _____

(SIGNATURE OF OFFICER, PARTNER OR OWNER WITH TITLE)

(SALES REPRESENTATIVE)

(APPROVED BY)

TERMS AND CONDITIONS

This purchase order is tendered by the Purchaser for acceptance by Vanguard Truck Center of Austin (hereinafter called the "Company"). It is understood that it will not be binding upon the Company unless accepted and signed by an authorized executive of the Company.

If the terms of payment herein provided are other than cash, the Purchaser agrees to execute and deliver to the Company, prior to the delivery of said vehicle(s), a security agreement, in the form customarily required by the Company, covering said vehicle(s) in order to secure the payment of the indebtedness due hereunder. The Purchaser further agrees that this purchase order shall be subject to all the terms and conditions of said security agreement, which shall supersede this purchase order to the extent inconsistent herewith; provided that Purchaser's warranty as to any used motor vehicle or equipment traded in by the Purchaser and taken by the Company as part of payment hereunder (hereinafter such used motor vehicle or equipment is called the "used equipment") shall survive the execution of the security agreement.

The Company shall not be held responsible for any loss, damage, detention, delay or failure to deliver resulting from any cause which is unavoidable or beyond its reasonable control, including, but not limited to fire, flood, natural disaster, strike or labor disturbance, accident, vandalism, riot or insurrection, war, any order, decree, law or regulation of any court, government or governmental agency, shortage of materials, demand in excess of available supply, failure or interruption of normal transportation or power facilities; NOR IN ANY EVENT SHALL THE COMPANY BE LIABLE FOR CONSEQUENTIAL DAMAGES, INCLUDING, BUT NOT LIMITED TO LOSS OF INCOME. The receipt of said vehicle(s) by the Purchaser upon delivery shall constitute a waiver of all claims for loss or damage due to delay.

The Purchaser warrants that the used equipment, if any, is free from all liens and/or encumbrances of any nature whatsoever, and that the Purchaser has good and marketable title to the used equipment at the time of delivery thereof to the Company. The used equipment is to be delivered to the Company in the same condition and appearance in which it was when first inspected by the Company or its agent. The Company, upon delivery of such used equipment, shall have the right once again to inspect such used equipment and the Company shall be the sole judge as to its condition, with the right to accept or reject the used equipment at its option. If the used equipment to be delivered to the Company is not in a condition and appearance as good as it was when first inspected by the Company, the Company shall have the right to revalue the amount of allowance offered for such equipment and the total cash purchase price shall be increased accordingly.

The Purchaser agrees that the amount of the allowance made upon the used equipment, if any, is to be applied by the Company as part payment on the purchase price of said vehicle(s).

In the event that the within purchase order is accepted by the Company and the Purchaser fails to accept delivery and perform this contract pursuant to its terms, the Purchaser authorizes the Company to retain the amount paid to the Company in cash and/or the used equipment on account of the purchase price of said vehicle(s) as liquidated damages in addition to such rights as the Company may have under law.

In the event that the within purchase order is cancelled by mutual written agreement of the Company and the Purchaser or if the Company is unable to make delivery of said vehicle(s), the Company will return and the Purchaser will accept the cash and the used equipment (or if the used equipment shall have been sold, the net amount received by the Company from the sale thereof) in full discharge of any obligations of the Company to the Purchaser hereunder.

The Purchaser agrees that all previous communications between the Purchaser and the Company, either verbal or written, with reference to the subject matter of this purchase order, are hereby abrogated. The Purchaser further agrees that no modification of this Agreement shall be binding upon the Company unless such modifications shall be in writing and agreed to and accepted in writing by a Sales Manager or authorized Home Office executive of the Company.

A security interest in said vehicle(s) shall remain in the Company until the payment in full of the purchase price or, if the terms of payment herein provided are other than cash, until the execution and delivery of a security agreement, as hereinabove provided, at which time the terms of said security agreement shall control with respect to the title and ownership of said vehicle(s).

In the event of Purchaser's failure to make payment of the purchase price when due, the Company may take immediate possession of said vehicle(s), without demand or further notice. For this purpose and in furtherance thereof, the Purchaser shall, if the Company so requests, make said vehicle(s) available to the Company at a reasonably convenient place designated by it, and the Company shall have the right, and the Purchaser does hereby authorize and empower the Company, its agents, servants or employees, to enter upon the premises wherever said vehicle(s) may be and remove the same; and the Purchaser hereby expressly waives any action or right of action of any kind whatsoever against the Company, its agents, servants or employees because of the removal, repossession or retention of said vehicle(s) or otherwise.

If the cost to the Company of insurance to be furnished by the Company hereunder is increased at any time prior to the delivery of said vehicle(s), the Purchaser agrees to pay for the insurance herein provided for at such increased rate.

It is agreed that if the cost of labor, materials, body, accessories or other equipment or component parts increases beyond the basis upon which the price set forth herein was established, then the Company, at any time before delivery, may give the Purchaser written notice of an increase in price, and such increased price shall be the contract price, unless Purchaser within ten days thereafter shall give Company written notice of cancellation. Any such increase in the contract price, pursuant to this provision, however, shall not prevent additional increases, if necessary, under the circumstances set forth herein at any time prior to delivery.

ALL TAXES NOW OR HEREAFTER IMPOSED UPON THE MANUFACTURER OR SALE OF SAID VEHICLE(S) SHALL BE PAID BY THE PURCHASER.

This instrument contains the entire agreement between the parties, and there are no understandings or representations not contained herein.

Customer Initials _____



Austin TX
 16870 South IH 35
 Buda TX 78610
 512-312-1146

Customer Proposal Letter

CALDWELL COUNTY
 1105 MAIN STREET
 LOCKHART, TX 78644
 (512) 227-1973

CALDWELL COUNTY Mike Warm, thank you for the opportunity to earn your business. We look forward to working with you on your business needs. Please accept the following proposal.

VEHICLE

Make Peterbilt Model 567 Year 2020 Stock Number _____
 Additional Vehicle and Accessories Description _____ To be delivered on or about _____

Price Based on 2 Units

~~123,249.00~~

Tractor

Quantity	1	Total
Truck Price per Unit	\$123,249.00	\$123,249.00
F E T (Factory & Dealer Paid)	\$0.00	\$0.00
Net Sales Price	\$123,249.00	\$123,249.00
Optional Extended Warranty(ies)		
State Sales Tax		
Documentary Fee	\$350.00	\$350.00
Administration Fee		
Vehicle Inventory Tax	\$266.71	\$266.71
Additional Taxes		
Tire Recycling Program		
Battery Disposal Fee		
Out of State Vehicle Fee		
Rebate(s)		
Total Sales Price (Including Rebate(s))	\$123,865.71	\$123,865.71
Trade Allowance (see DISCLAIMER Below)		\$0.00

*Tractor for Belly Dump
 alone*

Price for one

Sales Representative _____

Ronnie Rose

Purchaser _____

signature

printed name

signature

printed name

title

date

Accepted by Sales Manager or General Manager _____

signature

printed name

Quote good until 5/12/2019

Note: The above Customer Proposal is a quotation only. Sale terms subject to approval of Sales Manager of Dealer.

DISCLAIMER: Any order based on this Proposal subject to Customer executing Dealer's standard form Retail Purchase Order incorporating above terms. Any documentary fees, state tax, title, registration and license fees subject to adjustment and change. Actual F E T to be paid by Dealer, subject to adjustment. Any F E T variance will be responsibility of Dealer. Manufacturer has reserved the right to change the price to Dealer of any vehicle not currently in Dealer's stock, without notice to Dealer. If Quoted Vehicle(s) not currently in Dealer's stock, Dealer reserves right to change Quotation Total to reflect any price increases from Manufacturer. This Proposal is based upon Dealer's current and expected inventory, which is subject to change. Dealer not obligated to retain any specific vehicles in stock, nor maintain any specific inventory level. Dealer shall not be obligated to fulfill Proposal in event quoted vehicle(s) not in stock or available within requested delivery schedule at time Proposal accepted. Dealer shall not be liable for any delay in providing or inability to provide Quoted Vehicle(s), where such inability or delay is due, in whole or in part, to any cause beyond the reasonable control of Dealer or is without the gross negligence or intended misconduct of Dealer. Above listed Trade Value based upon current appraisal of Trade Vehicle(s). Dealer may adjust Trade Value of Trade Vehicle(s) to reflect changes in condition and/or mileage of Trade Vehicle(s) between date of current appraisal and acceptance of this Proposal by Customer.



Peterbilt Model 567



PRICED AT \$123,865.00

**2019 Peterbilt 567
Cummins X15
450HP / 1650TQ
Fuller FRO16210C 10 Speed
Stock # 1008746**

CONTACT INFO:

RONNIE ROSE, SALES
Call: 512-312-1146
Toll Free: 888-243-6241
Local: 512-523-3200
Fax: 512-523-3137

LOCATION:

Austin
16870 S. IH-35
Buda, TX 78610

HOURS:

Monday-Friday: 7:30 am-7:00 pm
Saturday: 8:00 am-3:00 pm

General

Unit Type New Heavy Duty
Make Peterbilt
Model 567
Year 2019
GVWR 53200
Stock Number 1008746

Day Cab

Type Unibilt
BBC 121
Suspension Fixed
Interior Prestige
Interior Color Sterling Gray

Exterior

Exterior Color WHITE

Engine

Engine MFG Cummins
Engine Model X15
Horse Power 450hp
Torque 1650 lb ft
Engine Brake Intebrake
Air Cleaner MFG Donaldson
Air Cleaner Type Under Hood

Chassis

Wheel Base 225 inches

Tires and Wheels

Front Wheel Aluminum
Front Tire MFG Yokohama
Front Tire Ply 16 Ply
Front Tire Size 24.5 inches
Rear Wheel Aluminum
Rear Tire MFG Yokohama

Rear Tire Ply 14 Ply

Rear Tire Size 24.5 inches

Fifth Wheel Model FW35

Fifth Wheel MFG Holland

Fifth Wheel Height 9.00 inches

Fifth Wheel Size 9.0 inches

Axle

Front Axle MFG Dana Spc

Front Axle Model D13211L

Front Axle Power Steering True

Front Axle Suspension TaperLeaf

Front Axle Suspension Weight 13,200 lbs

Front Axle Weight 13,200 lbs

Rear Axle MFG Dana Spc

Rear Axle Model DSP41

Rear Axle Ratio 3.55

Rear Axle Suspension Air Trac

Rear Axle Weight 40,000 lbs

Transmission

Manufacturer Fuller

Model FRO16210C

Speed 10 Speed

Torque 1650 lb ft

Fuel Tanks

Tank #1 Type Aluminum

Tank #1 Capacity 80 gallons

Tank #1 Size 26 in.

Tank #2 Type Aluminum

Tank #2 Capacity 100 gallons

Tank #2 Size 26 in.

Frame

Color Black

Rails 10 3/4 Steel

(27)

Unit Road Caldwell County

From: kevin beran [REDACTED]
Sent: Tuesday, March 26, 2019 12:55 PM
To: unitroad@co.caldwell.tx.us
Subject: 2020-Freightliner M2-106 Dump Truck-Spec & Quote
Attachments: Caldwell County-2020-M2 Dump Chassis Spec..docx; Caldwell County-(2020-M2-106 Tandem Dump Truck).xls

Hello Mike,

Attached are the detailed chassis specs and a buy board quote for the 2020 M2 Dump Trucks you'll be considering.

If we get the order within the next few weeks, it's likely that we can have them ready to roll by this year's end.

I will be sending the same kind of email on the other trucks and trailers you'll be considering.

I hope to have you quoted on all of the rest of the equipment by the end of the week!

Thanks again for the opportunity to help with your Trucking needs.

Have a GREAT day, 🍀

Kevin Beran
Freightliner of Austin
512-619-5152- Cell Phone
512-389-0000- Office- Ext.104

Hyd Dump Trucks



FREIGHTLINER OF AUSTIN

1701 Smith Rd.
Austin, Texas 78721

Bus: 512-389-0000
Fax: 512-389-2663

INV #:

BUYER'S ORDER

BUYER'S NAME CALDWELL COUNTY		TELEPHONE 512-398-7268	
ADDRESS 110 SOUTH MAIN ST.		CITY LOCKHART	STATE TX
YEAR 2020	MAKE FREIGHTLINER	MODEL/BODY M2-106 DUMP TRUCK	LICENSE PLATE 78644

A DOCUMENTARY FEE IS NOT AN OFFICIAL FEE. A DOCUMENTARY FEE IS NOT REQUIRED BY LAW, BUT MAY CHARGED TO BUYER FOR HANDLING DOCUMENTS RELATING TO THE SALE. A DOCUMENTARY FEE MAY NOT EXCEED A REASONABLE AMOUNT AGREED TO BY THE PARTIES. THIS NOTICE IS REQUIRED BY LAW.

UN CARGO DOCUMENTAL NO ES UN CALGO OFFICIAL. LA LEY NO EXIGE QUE SE IMPONGA UN CARGO DOCUMENTAL. PERO ESTE PODRIA COBRARSE A LOS COMPRADORES POR EL MANEJO DE LA DOCUMENTACION EN RELACION CON LE VENTA. UN CARGO DOCUMENTAL NO PUEDE EXCEDER UNA CANTIDAD PASONABLE ACORDADA POR LAS PARTES. ESTA NOTIFICACION SE EXIGE POR LEY.

MILEAGE:	
ORDER PROPOAL	
SELLING PRICE	\$105,539.00

INCLUDES:	
15FT. OX MAVERICK DUMP BODY	
ELECTRIC-ALUMINUM ARM TARP	
45 TON PINTLE HITCH	
BUY BOARD FEE	\$400.00

Disclaimer of Warranties
above decribed vehicle sold by Freightliner of Ausitn is sold as is, without either express or implied warranties of any kind. Freightliner of Austin, including warranties of merchantability, fitness, and Buyer will bear the entire expense of repairing or replacing any defects that presently exist or that may occur in the future, unless a written warranty by, or service contract with, Freightliner of Austin covering the describe vehicle is delivered in conjunction with or within 90 days following the time of purchase, but such vehicle or any of its component parts may be subject to warranty by the manufacuter thereof.

EXTENDED WARRANTY INFO. LISTED ON THE LAST PAGE OF THE DETAILED SPEC.

MILEAGE:	YEAR:	MAKE:	MODEL/BODY:	VIN:			
MILEAGE:	YEAR:	MAKE:	MODEL/BODY:	VIN:	TRADE-IN:		
PAYOFF TO:					TOTAL	\$105,939.00	
ADDRESS:					(Trade Allowance)		
GOOD UNTIL:					TRADING DIFFERENCE		
QUOTED BY:					SALES TAX	N/A	
SHOW LEIN TO:					DEALER'S INVENTORY TAX	N/A	
ADDRESS:					LICENSE FEE	N/A	
DATED:					DOCUMENTARY FEE	N/A	
DRAFT FOR \$					FEDERAL EXCISE TAX	N/A	
DRAFT THRU:					State Insp.:	TOTAL SALE PRICE	\$105,939.00
ADDRESS:					License:	PAYOFF ON TRADE	
					Title:	EXT. SERVICE AGREEMENT	
					Transfer:	LESS DEPOSIT	X 4
						Total Balance Due	\$423,756.00

county tax assessor-collector, is not a tax imposed on a consumer by the government, and is not required to be charged by the dealer to the buyer. The information you see on the window form for this vehicle is part of this contract. Information on the window form overrides any contrary printed information. La informacion que aparece en la ventanilla de este vehiculo forma parte de este contrato. La informacion contenida en el formulario de la ventanilla anula cualquier informacion que aparezca en el contrato de venta. If a credit purchase, this is an offer to purchase only. Buyer offers to purchase vehicle on credit term relationship is created. This order does not constitute an agreement for the extension of credit. Manufacturer/Distributor reserves the right to change the price of the vehicle. In the event that the price to Seller of the new vehicle ordered hereunder is changed prior to delivery to Buyer, Buyer agrees and accepts that the cash delivered to Buyer will be the amount of the new price. If the Buyer's used vehicle trade-in is not delivered to the Seller until delivery of the new vehicle, the trade-in will be reappraised at that time and Buyer agrees to determine the allowance, if any, made for the trade-in. Buyer agrees to deliver the original bill of sale and the title to an trade-in along with the delivery of the vehicle and all documents necessary or required to transfer legal title and ownership to Seller or its assigns. Buyer warrants the trade-in to be his property and free of all liens except as otherwise noted herein. Buyer further warrants that the trade-in has not been declared rebuilt salvage, reconditioned, nonrepairable, or flood damage not been tampered with and are in the condition as originally manufactured, except for ordinary wear, unless so disclosed. Seller makes no representations, and any information posted on the sale unit or contained in literature relating to the same reflect the results of tests performed, required or prescribed by government. It is expressly agreed to and understood by Buyer and Seller that in the event of a non-credit transaction, Seller retains a security interest in the purchase price paid the Seller for the vehicle. Buyer agrees to all the above listed charges.

BUYER'S SIGNATURE: _____ SELLER'S SIGNATURE _____ DATE _____
AUSTIN TRUCK & EQUIPMENT, LTD. DBA FREIGHTLINER OF AUSTIN

Prepared for:
Mike Cheatham
CALDWELL COUNTY
110 S MAIN ST
LOCKHART, TX 78644
Phone: 512-398-7268

Prepared by:
Kevin Beran
FREIGHTLINER OF AUSTIN
1701 SMITH ROAD
AUSTIN, TX 78721
Phone: 512-389-0000

A proposal for
CALDWELL COUNTY

Prepared by
FREIGHTLINER OF AUSTIN
Kevin Beran

Mar 26, 2019

Freightliner M2 106

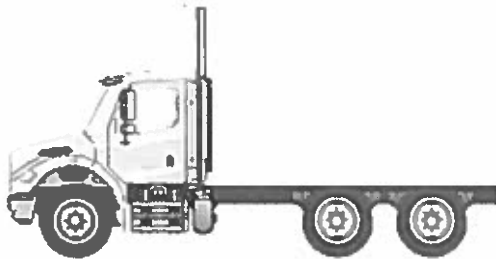

Components shown may not reflect all spec'd options and are not to scale



Prepared for:
 Mike Cheatham
 CALDWELL COUNTY
 110 S MAIN ST
 LOCKHART, TX 78644
 Phone: 512-398-7268

Prepared by:
 Kevin Beran
 FREIGHTLINER OF AUSTIN
 1701 SMITH ROAD
 AUSTIN, TX 78721
 Phone: 512-389-0000

S P E C I F I C A T I O N P R O P O S A L

Data Code	Description	Weight Front	Weight Rear	Retail Price
Price Level				
PRL-19M	M2 PRL-19M (EFF:01/15/19)			STD
Data Version				
DRL-011	SPECPRO21 DATA RELEASE VER 011			N/C
Vehicle Configuration				
001-172	M2 106 CONVENTIONAL CHASSIS	5,709	3,503	\$103,510.00
004-220	2020 MODEL YEAR SPECIFIED			STD
002-004	SET BACK AXLE - TRUCK			STD
019-001	TRAILER TOWING PROVISION AT END OF FRAME FOR TRUCK	10	10	\$1,083.00
003-001	LH PRIMARY STEERING LOCATION			STD
General Service				
AA1-003	TRUCK/TRAILER CONFIGURATION			N/C
AA6-002	DOMICILED, USA (EXCLUDING CALIFORNIA AND CARB OPT-IN STATES)			STD
A85-011	CONSTRUCTION SERVICE			N/C
A84-1GM	GOVERNMENT BUSINESS SEGMENT			N/C
AA4-010	DIRT/SAND/ROCK COMMODITY			N/C
AA5-002	TERRAIN/DUTY: 100% (ALL) OF THE TIME, IN TRANSIT, IS SPENT ON PAVED ROADS			STD
AB1-008	MAXIMUM 8% EXPECTED GRADE			STD
AB5-001	SMOOTH CONCRETE OR ASPHALT PAVEMENT - MOST SEVERE IN-TRANSIT (BETWEEN SITES) ROAD SURFACE			STD
995-091	MEDIUM TRUCK WARRANTY			STD
A66-99D	EXPECTED FRONT AXLE(S) LOAD : 12000.0 lbs			
A68-99D	EXPECTED REAR DRIVE AXLE(S) LOAD : 40000.0 lbs			
A63-99D	EXPECTED GROSS VEHICLE WEIGHT CAPACITY : 52000.0 lbs			
A70-99D	EXPECTED GROSS COMBINATION WEIGHT : 60000.0 lbs			



Prepared for:
 Mike Cheatham
 CALDWELL COUNTY
 110 S MAIN ST
 LOCKHART, TX 78644
 Phone: 512-398-7268

Prepared by:
 Kevin Beran
 FREIGHTLINER OF AUSTIN
 1701 SMITH ROAD
 AUSTIN, TX 78721
 Phone: 512-389-0000

Data Code	Description	Weight Front	Weight Rear	Retail Price
Truck Service				
AA3-004	END DUMP BODY			N/C
A88-99D	EXPECTED TRUCK BODY LENGTH : 15.0 ft			
AF3-165	OX BODIES (TBEI)			N/C
AF7-99D	EXPECTED BODY/PAYLOAD CG HEIGHT ABOVE FRAME "XX" INCHES : 32.0 in			
Tractor Service				
AA2-005	FLATBED TRAILER			N/C
AH6-001	SINGLE (1) TRAILER			N/C
Engine				
101-22P	CUM L9 300 HP @ 2000 RPM, 2200 GOV RPM, 860 LB/FT @ 1300 RPM	640	30	\$11,662.00
Electronic Parameters				
79A-078	78 MPH ROAD SPEED LIMIT			N/C
79B-000	CRUISE CONTROL SPEED LIMIT SAME AS ROAD SPEED LIMIT			N/C
79P-002	PTO RPM WITH CRUISE SET SWITCH - 700 RPM			N/C
79Q-003	PTO RPM WITH CRUISE RESUME SWITCH - 800 RPM			N/C
79S-001	PTO MODE CANCEL VEHICLE SPEED - 5 MPH			N/C
79U-007	PTO GOVERNOR RAMP RATE - 250 RPM PER SECOND			N/C
80G-002	PTO MINIMUM RPM - 700			N/C
80J-002	REGEN INHIBIT SPEED THRESHOLD - 5 MPH			N/C
Engine Equipment				
99C-017	2016 ONBOARD DIAGNOSTICS/2010 EPA/CARB/FINAL GHG17 CONFIGURATION			STD
99D-011	2008 CARB EMISSION CERTIFICATION - CLEAN IDLE (INCLUDES 6X4 INCH LABEL ON LOWER FORWARD CORNER OF DRIVER DOOR)			\$109.00
13E-001	STANDARD OIL PAN			STD
105-001	ENGINE MOUNTED OIL CHECK AND FILL			STD
133-004	ONE PIECE VALVE COVER			STD
014-1B5	SIDE OF HOOD AIR INTAKE WITH DONALDSON HIGH CAPACITY AIR CLEANER WITH SAFETY ELEMENT, FIREWALL MOUNTED			\$50.00
124-1D7	DR 12V 160 AMP 28-SI QUADRAMOUNT PAD ALTERNATOR WITH REMOTE BATTERY VOLT SENSE			STD
292-208	(2) DTNA GENUINE, FLOODED STARTING, MIN 2250CCA, 390RC, THREADED STUD BATTERIES			\$57.00



Prepared for:
 Mike Cheatham
 CALDWELL COUNTY
 110 S MAIN ST
 LOCKHART, TX 78644
 Phone: 512-398-7268

Prepared by:
 Kevin Beran
 FREIGHTLINER OF AUSTIN
 1701 SMITH ROAD
 AUSTIN, TX 78721
 Phone: 512-389-0000

Data Code	Description	Weight Front	Weight Rear	Retail Price
290-017	BATTERY BOX FRAME MOUNTED			STD
281-001	STANDARD BATTERY JUMPERS			STD
282-001	SINGLE BATTERY BOX FRAME MOUNTED LH SIDE UNDER CAB			STD
291-017	WIRE GROUND RETURN FOR BATTERY CABLES WITH ADDITIONAL FRAME GROUND RETURN			STD
289-001	NON-POLISHED BATTERY BOX COVER			STD
87P-001	CAB AUXILIARY POWER CABLE	5		N/C
295-029	POSITIVE AND NEGATIVE POSTS FOR JUMPSTART LOCATED ON FRAME NEXT TO STARTER	2		\$92.00
107-032	CUMMINS TURBOCHARGED 18.7 CFM AIR COMPRESSOR WITH INTERNAL SAFETY VALVE			STD
108-002	STANDARD MECHANICAL AIR COMPRESSOR GOVERNOR			STD
131-013	AIR COMPRESSOR DISCHARGE LINE			STD
152-041	ELECTRONIC ENGINE INTEGRAL SHUTDOWN PROTECTION SYSTEM			STD
128-076	CUMMINS EXHAUST BRAKE INTEGRAL WITH VARIABLE GEOMETRY TURBO WITH ON/OFF DASH SWITCH	20		N/C
016-1C2	RH OUTBOARD UNDER STEP MOUNTED HORIZONTAL AFTERTREATMENT SYSTEM ASSEMBLY WITH RH B-PILLAR MOUNTED VERTICAL TAILPIPE	30	25	\$823.00
28F-002	ENGINE AFTERTREATMENT DEVICE, AUTOMATIC OVER THE ROAD REGENERATION AND DASH MOUNTED REGENERATION REQUEST SWITCH			STD
239-026	10 FOOT 06 INCH (126 INCH+0/-5.9 INCH) EXHAUST SYSTEM HEIGHT			(\$4.00)
237-1CR	RH CURVED VERTICAL TAILPIPE B-PILLAR MOUNTED ROUTED FROM STEP			N/C
23U-002	13 GALLON DIESEL EXHAUST FLUID TANK	35	10	\$105.00
30N-003	100 PERCENT DIESEL EXHAUST FLUID FILL			\$17.00
23Z-002	NON-POLISHED ALUMINUM DIESEL EXHAUST FLUID TANK COVER	15	5	\$144.00
43X-002	LH MEDIUM DUTY STANDARD DIESEL EXHAUST FLUID TANK LOCATION			STD
23Y-001	STANDARD DIESEL EXHAUST FLUID PUMP MOUNTING			STD
43Y-001	STANDARD DIESEL EXHAUST FLUID TANK CAP			STD
242-001	STAINLESS STEEL AFTERTREATMENT DEVICE/MUFFLER/TAILPIPE SHIELD			\$48.00



Prepared for:
 Mike Cheatham
 CALDWELL COUNTY
 110 S MAIN ST
 LOCKHART, TX 78644
 Phone: 512-398-7268

Prepared by:
 Kevin Beran
 FREIGHTLINER OF AUSTIN
 1701 SMITH ROAD
 AUSTIN, TX 78721
 Phone: 512-389-0000

Data Code	Description	Weight Front	Weight Rear	Retail Price
273-018	HORTON DRIVEMASTER ADVANTAGE ON/OFF FAN DRIVE			N/C
276-001	AUTOMATIC FAN CONTROL WITHOUT DASH SWITCH, NON ENGINE MOUNTED			STD
110-003	CUMMINS SPIN ON FUEL FILTER			STD
118-008	COMBINATION FULL FLOW/BYPASS OIL FILTER			N/C
120-009	FLEETGUARD PLAIN COOLANT FILTER			\$122.00
266-101	900 SQUARE INCH ALUMINUM RADIATOR	15		N/C
103-039	ANTIFREEZE TO -34F, OAT (NITRITE AND SILICATE FREE) EXTENDED LIFE COOLANT			STD
171-007	GATES BLUE STRIPE COOLANT HOSES OR EQUIVALENT			STD
172-001	CONSTANT TENSION HOSE CLAMPS FOR COOLANT HOSES			STD
270-016	RADIATOR DRAIN VALVE			STD
168-002	LOWER RADIATOR GUARD			STD
134-001	ALUMINUM FLYWHEEL HOUSING			STD
132-004	ELECTRIC GRID AIR INTAKE WARMER			STD
155-058	DELCO 12V 38MT HD STARTER WITH INTEGRATED MAGNETIC SWITCH			N/C

Transmission

342-584	ALLISON 3500 RDS AUTOMATIC TRANSMISSION WITH PTO PROVISION	200	60	\$6,711.00
---------	------------------------------------------------------------	-----	----	------------

Transmission Equipment

343-339	ALLISON VOCATIONAL PACKAGE 223 - AVAILABLE ON 3000/4000 PRODUCT FAMILIES WITH VOCATIONAL MODELS RDS, HS, MH AND TRV			N/C
84B-012	ALLISON VOCATIONAL RATING FOR ON/OFF HIGHWAY APPLICATIONS AVAILABLE WITH ALL PRODUCT FAMILIES			N/C
84C-023	PRIMARY MODE GEARS, LOWEST GEAR 1, START GEAR 1, HIGHEST GEAR 6, AVAILABLE FOR 3000/4000 PRODUCT FAMILIES ONLY			N/C
84D-023	SECONDARY MODE GEARS, LOWEST GEAR 1, START GEAR 1, HIGHEST GEAR 6, AVAILABLE FOR 3000/4000 PRODUCT FAMILIES ONLY			N/C
84E-000	PRIMARY SHIFT SCHEDULE RECOMMENDED BY DTNA AND ALLISON, THIS DEFINED BY ENGINE AND VOCATIONAL USAGE			STD
84F-000	SECONDARY SHIFT SCHEDULE RECOMMENDED BY DTNA AND ALLISON, THIS DEFINED BY ENGINE AND VOCATIONAL USAGE			STD



Prepared for:
 Mike Cheatham
 CALDWELL COUNTY
 110 S MAIN ST
 LOCKHART, TX 78644
 Phone: 512-398-7268

Prepared by:
 Kevin Beran
 FREIGHTLINER OF AUSTIN
 1701 SMITH ROAD
 AUSTIN, TX 78721
 Phone: 512-389-0000

Data Code	Description	Weight Front	Weight Rear	Retail Price
84G-000	PRIMARY SHIFT SPEED RECOMMENDED BY DTNA AND ALLISON, THIS DEFINED BY ENGINE AND VOCATIONAL USAGE			STD
84H-000	SECONDARY SHIFT SPEED RECOMMENDED BY DTNA AND ALLISON, THIS DEFINED BY ENGINE AND VOCATIONAL USAGE			STD
84J-000	ENGINE BRAKE RANGE PRESELECT RECOMMENDED BY DTNA AND ALLISON, THIS DEFINED BY ENGINE AND VOCATIONAL USAGE			STD
84K-000	ENGINE BRAKE RANGE ALTERNATE PRESELECT RECOMMENDED BY DTNA AND ALLISON, THIS DEFINED BY ENGINE AND VOCATIONAL USAGE			STD
84N-200	FUEL SENSE 2.0 DISABLED - MAXIMUM PERFORMANCE - TABLE BASED			STD
84U-000	DRIVER SWITCH INPUT - DEFAULT - NO SWITCHES			STD
353-066	VEHICLE INTERFACE WIRING CONNECTOR WITH BLUNT CUTS, AT END OF FRAME			\$62.00
34C-001	ELECTRONIC TRANSMISSION CUSTOMER ACCESS CONNECTOR FIREWALL MOUNTED			\$23.00
362-035	CUSTOMER INSTALLED CHELSEA 277 SERIES PTO			N/C
363-001	PTO MOUNTING, LH SIDE OF MAIN TRANSMISSION			N/C
341-018	MAGNETIC PLUGS, ENGINE DRAIN, TRANSMISSION DRAIN, AXLE(S) FILL AND DRAIN			STD
345-003	PUSH BUTTON ELECTRONIC SHIFT CONTROL, DASH MOUNTED			N/C
97G-004	TRANSMISSION PROGNOSTICS - ENABLED 2013			N/C
370-015	WATER TO OIL TRANSMISSION COOLER, IN RADIATOR END TANK			STD
346-003	TRANSMISSION OIL CHECK AND FILL WITH ELECTRONIC OIL LEVEL CHECK			N/C
35T-001	SYNTHETIC TRANSMISSION FLUID (TES-295 COMPLIANT)			STD

Front Axle and Equipment

400-1A6	DETROIT DA-F-12.0-3 12,000# FF1 71.5 KPI/3.74 DROP SINGLE FRONT AXLE			STD
402-020	MERITOR 15X4 Q+ CAM FRONT BRAKES			STD
403-002	NON-ASBESTOS FRONT BRAKE LINING			STD
419-023	CONMET CAST IRON FRONT BRAKE DRUMS			STD
409-006	FRONT OIL SEALS			STD



Prepared for:
 Mike Cheatham
 CALDWELL COUNTY
 110 S MAIN ST
 LOCKHART, TX 78644
 Phone: 512-398-7268

Prepared by:
 Kevin Beran
 FREIGHTLINER OF AUSTIN
 1701 SMITH ROAD
 AUSTIN, TX 78721
 Phone: 512-389-0000

Data Code	Description	Weight Front	Weight Rear	Retail Price
408-001	VENTED FRONT HUB CAPS WITH WINDOW, CENTER AND SIDE PLUGS - OIL			STD
416-022	STANDARD SPINDLE NUTS FOR ALL AXLES			STD
405-002	MERITOR AUTOMATIC FRONT SLACK ADJUSTERS			STD
536-050	TRW THP-60 POWER STEERING			STD
539-003	POWER STEERING PUMP			STD
534-015	2 QUART SEE THROUGH POWER STEERING RESERVOIR			STD
40T-002	SYNTHETIC 75W-90 FRONT AXLE LUBE			\$14.00
Front Suspension				
620-1F0	12,000# DUAL TAPERLEAF FRONT SUSPENSION	42		\$57.00
619-005	MAINTENANCE FREE RUBBER BUSHINGS - FRONT SUSPENSION			STD
410-001	FRONT SHOCK ABSORBERS			STD
Rear Axle and Equipment				
420-1K4	MT-40-14XP 40,000# R-SERIES TANDEM REAR AXLE		2,530	\$10,328.00
421-529	5.29 REAR AXLE RATIO			N/C
424-003	IRON REAR AXLE CARRIER WITH OPTIONAL HEAVY DUTY AXLE HOUSING		30	\$101.00
386-073	MXL 17T MERITOR EXTENDED LUBE MAIN DRIVELINE WITH HALF ROUND YOKES			STD
388-073	MXL 17T MERITOR EXTENDED LUBE INTERAXLE DRIVELINE WITH HALF ROUND YOKES			N/C
452-006	DRIVER CONTROLLED TRACTION DIFFERENTIAL - BOTH TANDEM REAR AXLES		30	\$1,499.00
878-023	(1) INTERAXLE LOCK VALVE, (1) DRIVER CONTROLLED DIFFERENTIAL LOCK FORWARD-REAR AND REAR-REAR AXLE VALVE			N/C
87A-001	BLINKING LAMP WITH EACH INTERAXLE LOCK SWITCH, INTERAXLE UNLOCK DEFAULT WITH IGNITION OFF			N/C
87B-004	BLINKING LAMP WITH EACH MODE SWITCH, DIFFERENTIAL UNLOCK WITH IGNITION OFF, ACTIVE <5 MPH			N/C
423-020	MERITOR 16.5X7 Q+ CAST SPIDER CAM REAR BRAKES, DOUBLE ANCHOR, FABRICATED SHOES			\$12.00
433-002	NON-ASBESTOS REAR BRAKE LINING			STD
434-011	BRAKE CAMS AND CHAMBERS ON FORWARD SIDE OF DRIVE AXLE(S)			N/C
451-023	CONMET CAST IRON REAR BRAKE DRUMS			STD



Prepared for:
 Mike Cheatham
 CALDWELL COUNTY
 110 S MAIN ST
 LOCKHART, TX 78644
 Phone: 512-398-7268

Prepared by:
 Kevin Beran
 FREIGHTLINER OF AUSTIN
 1701 SMITH ROAD
 AUSTIN, TX 78721
 Phone: 512-389-0000

Data Code	Description	Weight Front	Weight Rear	Retail Price
440-006	REAR OIL SEALS			STD
426-101	WABCO TRISTOP D LONGSTROKE 2-DRIVE AXLE SPRING PARKING CHAMBERS		20	N/C
428-003	HALDEX AUTOMATIC REAR SLACK ADJUSTERS			\$92.00
41T-002	SYNTHETIC 75W-90 REAR AXLE LUBE			STD
Rear Suspension				
622-1A0	TUFTRAC 40,000# REAR SPRING SUSPENSION		410	\$3,356.00
621-055	TUFTRAC STANDARD RIDE HEIGHT			N/C
431-003	AXLE CLAMPING GROUP			N/C
624-009	54 INCH AXLE SPACING			N/C
623-006	FORE/AFT AND TRANSVERSE CONTROL RODS			N/C
439-002	REAR SHOCK ABSORBERS - TWO AXLES (TANDEM)		40	\$161.00
Brake System				
018-002	AIR BRAKE PACKAGE			STD
490-101	WABCO 4S/4M ABS WITH TRACTION CONTROL, WITH ATC OFF-ROAD SWITCH			\$199.00
871-001	REINFORCED NYLON, FABRIC BRAID AND WIRE BRAID CHASSIS AIR LINES			STD
904-001	FIBER BRAID PARKING BRAKE HOSE			STD
412-001	STANDARD BRAKE SYSTEM VALVES			STD
46D-002	STANDARD AIR SYSTEM PRESSURE PROTECTION SYSTEM			STD
413-002	STD U.S. FRONT BRAKE VALVE			STD
432-003	RELAY VALVE WITH 5-8 PSI CRACK PRESSURE, NO REAR PROPORTIONING VALVE			STD
480-088	WABCO SYSTEM SAVER HP WITH INTEGRAL AIR GOVERNOR AND HEATER			STD
479-015	AIR DRYER FRAME MOUNTED			STD
460-001	STEEL AIR BRAKE RESERVOIRS			STD
607-001	CLEAR FRAME RAILS FROM BACK OF CAB TO FRONT REAR SUSPENSION BRACKET, BOTH RAILS OUTBOARD			\$63.00
477-004	PULL CABLES ON ALL AIR RESERVOIR(S)			\$3.00
Trailer Connections				
914-001	AIR CONNECTIONS TO END OF FRAME WITH GLAD HANDS FOR TRUCK AND NO DUST COVERS			N/C
296-010	PRIMARY CONNECTOR/RECEPTACLE WIRED FOR SEPARATE STOP/TURN, ABS CENTER PIN POWERED THROUGH IGNITION			N/C



Prepared for:
 Mike Cheatham
 CALDWELL COUNTY
 110 S MAIN ST
 LOCKHART, TX 78644
 Phone 512-398-7268

Prepared by:
 Kevin Beran
 FREIGHTLINER OF AUSTIN
 1701 SMITH ROAD
 AUSTIN, TX 78721
 Phone 512-389-0000

Data Code	Description	Weight Front	Weight Rear	Retail Price
297-001	SAE J560 7-WAY PRIMARY TRAILER CABLE RECEPTACLE MOUNTED END OF FRAME			N/C
335-004	UPGRADED CHASSIS MULTIPLEXING UNIT			STD
32A-002	UPGRADED BULKHEAD MULTIPLEXING UNIT			STD
Wheelbase & Frame				
545-487	4875MM (192 INCH) WHEELBASE			N/C
546-101	1 1/32X3-1/2X10-15/16 INCH STEEL FRAME (8.73MMX277.8MM/0.344X10.94 INCH) 120KSI	120	120	\$532.00
547-001	1/4 INCH (6.35MM) C-CHANNEL INNER FRAME REINFORCEMENT	140	360	\$894.00
552-030	1600MM (63 INCH) REAR FRAME OVERHANG			STD
55W-006	FRAME OVERHANG RANGE: 61 INCH TO 70 INCH			N/C
AC8-99D	CALC'D BACK OF CAB TO REAR SUSP C/L (CA) : 126.38 in			
AE8-99D	CALCULATED EFFECTIVE BACK OF CAB TO REAR SUSPENSION C/L (CA) : 123.38 in			
AE4-99D	CALC'D FRAME LENGTH - OVERALL : 293.9			
FSS-0LH	CALCULATED FRAME SPACE LH SIDE : 37.52 in			N/C
FSS-0RH	CALCULATED FRAME SPACE RH SIDE : 175.48 in			N/C
AM6-99D	CALC'D SPACE AVAILABLE FOR DECKPLATE : 126.45 in			
553-001	SQUARE END OF FRAME			STD
550-001	FRONT CLOSING CROSSMEMBER			STD
559-001	STANDARD WEIGHT ENGINE CROSSMEMBER			STD
561-001	STANDARD CROSSMEMBER BACK OF TRANSMISSION			STD
562-001	STANDARD MIDSHIP #1 CROSSMEMBER(S)			STD
572-001	STANDARD REARMOST CROSSMEMBER			STD
565-002	HEAVY DUTY SUSPENSION CROSSMEMBER		30	N/C
Chassis Equipment				
556-1AP	THREE-PIECE 14 INCH PAINTED STEEL BUMPER WITH COLLAPSIBLE ENDS	30		\$65.00
558-001	FRONT TOW HOOKS - FRAME MOUNTED	15		\$74.00
574-001	BUMPER MOUNTING FOR SINGLE LICENSE PLATE			STD
586-024	FENDER AND FRONT OF HOOD MOUNTED FRONT MUDFLAPS			STD
551-007	GRADE 8 THREADED HEX HEADED FRAME FASTENERS			STD



Prepared for:
 Mike Cheatham
 CALDWELL COUNTY
 110 S MAIN ST
 LOCKHART, TX 78644
 Phone: 512-398-7268

Prepared by:
 Kevin Beran
 FREIGHTLINER OF AUSTIN
 1701 SMITH ROAD
 AUSTIN, TX 78721
 Phone: 512-389-0000

Data Code	Description	Weight Front	Weight Rear	Retail Price
Fuel Tanks				
204-034	80 GALLON/302 LITER RECTANGULAR ALUMINUM FUEL TANK - LH	40	10	\$291.00
218-005	RECTANGULAR FUEL TANK(S)			STD
215-005	PLAIN ALUMINUM/PAINTED STEEL FUEL/HYDRAULIC TANK(S) WITH PAINTED BANDS			STD
212-007	FUEL TANK(S) FORWARD			STD
664-001	PLAIN STEP FINISH			STD
205-001	FUEL TANK CAP(S)			STD
122-1H3	DETROIT FUEL/WATER SEPARATOR WITH WATER IN FUEL SENSOR	-5		N/C
216-020	EQUIFLO INBOARD FUEL SYSTEM			STD
11F-998	NO NATURAL GAS VEHICLE FUEL TANK VENT LINE/STACK			STD
202-016	HIGH TEMPERATURE REINFORCED NYLON FUEL LINE			STD
Tires				
093-1RK	MICHELIN X WORKS Z 11R22.5 16 PLY RADIAL FRONT TIRES	42		\$80.00
094-1UY	MICHELIN X MULTI D 11R22.5 16 PLY RADIAL REAR TIRES (NORTH AMERICAN ONLY)		120	(\$80.00)
Hubs				
418-060	CONMET PRESET PLUS PREMIUM IRON FRONT HUBS			STD
450-060	CONMET PRESET PLUS PREMIUM IRON REAR HUBS			STD
Wheels				
502-545	MAXION WHEELS 90260 22.5X8 25 10-HUB PILOT 6.13 INSET 2-HAND HD STEEL DISC FRONT WHEELS	40		\$74.00
505-524	MAXION WHEELS 90541 22.5X8 25 10-HUB PILOT 2-HAND STEEL DISC REAR WHEELS			N/C
496-011	FRONT WHEEL MOUNTING NUTS			STD
497-011	REAR WHEEL MOUNTING NUTS			STD
Cab Exterior				
829-071	106 INCH BBC FLAT ROOF ALUMINUM CONVENTIONAL CAB			STD
650-008	AIR CAB MOUNTING			\$121.00
705-012	CAB ROOF REINFORCEMENTS FOR ROOF MOUNTED COMPONENTS	2		\$63.00



Prepared for:
 Mike Cheatham
 CALDWELL COUNTY
 110 S MAIN ST
 LOCKHART, TX 78644
 Phone: 512-398-7268

Prepared by:
 Kevin Beran
 FREIGHTLINER OF AUSTIN
 1701 SMITH ROAD
 AUSTIN, TX 78721
 Phone: 512-389-0000

Data Code	Description	Weight Front	Weight Rear	Retail Price
648-002	NONREMOVABLE BUGSCREEN MOUNTED BEHIND GRILLE			\$36.00
678-001	LH AND RH GRAB HANDLES			STD
646-023	HOOD MOUNTED CHROMED PLASTIC GRILLE			\$155.00
65X-003	CHROME HOOD MOUNTED AIR INTAKE GRILLE			\$49.00
644-004	FIBERGLASS HOOD			STD
690-002	TUNNEL/FIREWALL LINER			\$35.00
727-066	DUAL 26 INCH RECTANGULAR POLISHED ALUMINUM AIR HORNS ROOF MOUNTED	8		\$185.00
726-001	SINGLE ELECTRIC HORN			STD
728-002	DUAL HORN SHIELDS			N/C
657-001	DOOR LOCKS AND IGNITION SWITCH KEYED THE SAME			STD
575-001	REAR LICENSE PLATE MOUNT END OF FRAME			STD
312-038	INTEGRAL HEADLIGHT/MARKER ASSEMBLY WITH CHROME BEZEL			N/C
302-047	LED AERODYNAMIC MARKER LIGHTS			\$34.00
311-001	DAYTIME RUNNING LIGHTS			\$18.00
294-042	FREIGHTLINER LED FLANGE MOUNTED STOP/TAIL/TURN LIGHTS WITH SEPARATE INCANDESCENT BACKUP LIGHTS		5	\$107.00
300-015	STANDARD FRONT TURN SIGNAL LAMPS			STD
744-1BM	DUAL WEST COAST BRIGHT FINISH HEATED MIRRORS			\$140.00
797-001	DOOR MOUNTED MIRRORS			STD
796-001	102 INCH EQUIPMENT WIDTH			STD
743-204	LH AND RH 8 INCH BRIGHT FINISH CONVEX MIRRORS MOUNTED UNDER PRIMARY MIRRORS			N/C
74A-001	RH DOWN VIEW MIRROR			\$24.00
729-001	STANDARD SIDE/REAR REFLECTORS			STD
677-016	DUAL LEVEL CAB ENTRY STEPS ON BOTH SIDES			N/C
764-010	COMPOSITE EXTERIOR SUN VISOR	10		\$280.00
768-043	63X14 INCH TINTED REAR WINDOW			STD
661-003	TINTED DOOR GLASS LH AND RH WITH TINTED NON-OPERATING WING WINDOWS			STD
654-003	MANUAL DOOR WINDOW REGULATORS			STD
663-013	TINTED WINDSHIELD			STD
659-019	2 GALLON WINDSHIELD WASHER RESERVOIR WITHOUT FLUID LEVEL INDICATOR, FRAME MOUNTED			STD



Prepared for:
 Mike Cheatham
 CALDWELL COUNTY
 110 S MAIN ST
 LOCKHART, TX 78644
 Phone: 512-398-7268

Prepared by:
 Kevin Beran
 FREIGHTLINER OF AUSTIN
 1701 SMITH ROAD
 AUSTIN, TX 78721
 Phone: 512-389-0000

Data Code	Description	Weight Front	Weight Rear	Retail Price
Cab interior				
707-1AK	OPAL GRAY VINYL INTERIOR			N/C
706-013	MOLDED PLASTIC DOOR PANEL			STD
708-013	MOLDED PLASTIC DOOR PANEL			STD
772-006	BLACK MATS WITH SINGLE INSULATION			STD
785-001	DASH MOUNTED ASH TRAYS AND LIGHTER			\$13.00
691-008	FORWARD ROOF MOUNTED CONSOLE WITH UPPER STORAGE COMPARTMENTS WITHOUT NETTING			STD
694-010	IN DASH STORAGE BIN			STD
696-012	CENTER STORAGE CONSOLE MOUNTED ON BACKWALL	20		\$26.00
742-007	(2) CUP HOLDERS LH AND RH DASH			STD
680-006	GRAY/CHARCOAL FLAT DASH			STD
860-004	SMART SWITCH EXPANSION MODULE			\$198.00
720-003	5 LB. FIRE EXTINGUISHER	10		\$60.00
700-002	HEATER, DEFROSTER AND AIR CONDITIONER			STD
701-001	STANDARD HVAC DUCTING			STD
703-005	MAIN HVAC CONTROLS WITH RECIRCULATION SWITCH			STD
170-015	STANDARD HEATER PLUMBING			STD
130-041	VALEO HEAVY DUTY A/C REFRIGERANT COMPRESSOR			STD
702-002	BINARY CONTROL, R-134A			STD
739-033	STANDARD INSULATION			STD
285-027	SOLID-STATE CIRCUIT PROTECTION AND FUSES WITH SPARE FUSE KIT			\$33.00
280-007	12V NEGATIVE GROUND ELECTRICAL SYSTEM			STD
324-011	DOME DOOR ACTIVATED LH AND RH, DUAL READING LIGHTS, FORWARD CAB ROOF			\$59.00
655-001	CAB DOOR LATCHES WITH MANUAL DOOR LOCKS			STD
284-023	(1) 12 VOLT POWER SUPPLY IN DASH			\$21.00
722-028	TRIANGULAR REFLECTORS KIT WITHOUT FLARES SHIPPED LOOSE IN CAB	10		\$24.00
756-1J3	BASIC HIGH BACK AIR SUSPENSION DRIVER SEAT WITH MECHANICAL LUMBAR AND INTEGRATED CUSHION EXTENSION	30		\$212.00
760-1DC	BASIC HIGH BACK NON SUSPENSION PASSENGER SEAT			STD
759-007	DUAL DRIVER SEAT ARMRESTS, NO PASSENGER SEAT ARMRESTS	4		\$69.00



Prepared for:
 Mike Cheatham
 CALDWELL COUNTY
 110 S MAIN ST
 LOCKHART, TX 78644
 Phone: 512-398-7268

Prepared by:
 Kevin Beran
 FREIGHTLINER OF AUSTIN
 1701 SMITH ROAD
 AUSTIN, TX 78721
 Phone: 512-389-0000

Data Code	Description	Weight Front	Weight Rear	Retail Price
711-004	LH AND RH INTEGRAL DOOR PANEL ARMRESTS			STD
758-014	BLACK CORDURA PLUS CLOTH DRIVER SEAT COVER			\$2.00
761-014	BLACK CORDURA PLUS CLOTH PASSENGER SEAT COVER			\$4.00
763-101	BLACK SEAT BELTS			STD
532-001	FIXED STEERING COLUMN			STD
540-016	18 INCH (450MM) LEATHER WRAPPED STEERING WHEEL			\$102.00
765-002	DRIVER AND PASSENGER INTERIOR SUN VISORS			STD

Instruments & Controls

732-004	GRAY DRIVER INSTRUMENT PANEL			STD
734-004	GRAY CENTER INSTRUMENT PANEL			STD
870-001	BLACK GAUGE BEZELS			STD
486-001	LOW AIR PRESSURE INDICATOR LIGHT AND AUDIBLE ALARM			STD
840-002	2 INCH PRIMARY AND SECONDARY AIR PRESSURE GAUGES			STD
198-003	DASH MOUNTED AIR RESTRICTION INDICATOR WITH GRADUATIONS			\$36.00
721-001	97 DB BACKUP ALARM		3	\$44.00
149-013	ELECTRONIC CRUISE CONTROL WITH SWITCHES IN LH SWITCH PANEL			STD
156-007	KEY OPERATED IGNITION SWITCH AND INTEGRAL START POSITION; 4 POSITION OFF/RUN/START/ACCESSORY			STD
811-042	ICU3S, 132X48 DISPLAY WITH DIAGNOSTICS, 28 LED WARNING LAMPS AND DATA LINKED			STD
160-038	HEAVY DUTY ONBOARD DIAGNOSTICS INTERFACE CONNECTOR LOCATED BELOW LH DASH			STD
844-001	2 INCH ELECTRIC FUEL GAUGE			STD
148-003	PROGRAMMABLE RPM CONTROL - ELECTRONIC ENGINE			STD
856-001	ELECTRICAL ENGINE COOLANT TEMPERATURE GAUGE			STD
864-001	2 INCH TRANSMISSION OIL TEMPERATURE GAUGE			STD
830-017	ENGINE AND TRIP HOUR METERS INTEGRAL WITHIN DRIVER DISPLAY			STD
372-051	CUSTOMER FURNISHED AND INSTALLED PTO CONTROLS			N/C
852-002	ELECTRIC ENGINE OIL PRESSURE GAUGE			STD



Prepared for:
 Mike Cheatham
 CALDWELL COUNTY
 110 S MAIN ST
 LOCKHART, TX 78644
 Phone: 512-398-7268

Prepared by:
 Kevin Beran
 FREIGHTLINER OF AUSTIN
 1701 SMITH ROAD
 AUSTIN, TX 78721
 Phone: 512-389-0000

Data Code	Description	Weight Front	Weight Rear	Retail Price
679-001	OVERHEAD INSTRUMENT PANEL			\$76.00
746-114	AM/FM/WB WORLD TUNER RADIO WITH AUXILIARY INPUT, J1939	10		\$290.00
747-001	DASH MOUNTED RADIO			N/C
750-002	(2) RADIO SPEAKERS IN CAB			N/C
753-001	AM/FM ANTENNA MOUNTED ON FORWARD LH ROOF			N/C
748-006	POWER AND GROUND WIRING PROVISION OVERHEAD			\$23.00
749-001	ROOF/OVERHEAD CONSOLE CB RADIO PROVISION			\$92.00
810-027	ELECTRONIC MPH SPEEDOMETER WITH SECONDARY KPH SCALE, WITHOUT ODOMETER			STD
817-001	STANDARD VEHICLE SPEED SENSOR			STD
812-001	ELECTRONIC 3000 RPM TACHOMETER			STD
162-011	IDLE LIMITER, ELECTRONIC ENGINE			STD
329-015	ONE ON/OFF ROCKER SWITCH IN THE DASH WITH INDICATOR LIGHT AND WIRE ROUTED TO CHASSIS AT BACK OF CAB, LABEL OPT			\$33.00
81Y-001	PRE-TRIP LAMP INSPECTION, ALL OUTPUTS FLASH, WITH SMART SWITCH			\$12.00
482-001	BW TRACTOR PROTECTION VALVE			N/C
883-001	TRAILER HAND CONTROL BRAKE VALVE			N/C
836-015	DIGITAL VOLTAGE DISPLAY INTEGRAL WITH DRIVER DISPLAY			STD
660-008	SINGLE ELECTRIC WINDSHIELD WIPER MOTOR WITH DELAY			STD
304-001	MARKER LIGHT SWITCH INTEGRAL WITH HEADLIGHT SWITCH			STD
882-021	TWO VALVE PARKING BRAKE SYSTEM WITH DASH VALVE CONTROL AUTONEUTRAL AND WARNING INDICATOR			N/C
299-013	SELF CANCELING TURN SIGNAL SWITCH WITH DIMMER, WASHER/WIPER AND HAZARD IN HANDLE			STD
298-039	INTEGRAL ELECTRONIC TURN SIGNAL FLASHER WITH HAZARD LAMPS OVERRIDING STOP LAMPS			STD

Design

065-000	PAINT: ONE SOLID COLOR	STD
---------	------------------------	-----

Color

980-5F6	CAB COLOR A: L0006EB WHITE ELITE BC	STD
---------	-------------------------------------	-----



Prepared for:
 Mike Cheatham
 CALDWELL COUNTY
 110 S MAIN ST
 LOCKHART, TX 78644
 Phone: 512-398-7268

Prepared by:
 Kevin Beran
 FREIGHTLINER OF AUSTIN
 1701 SMITH ROAD
 AUSTIN, TX 78721
 Phone: 512-389-0000

Data Code	Description	Weight Front	Weight Rear	Retail Price
986-020	BLACK, HIGH SOLIDS POLYURETHANE CHASSIS PAINT			STD
962-972	POWDER WHITE (N0006EA) FRONT WHEELS/RIMS (PKWHT21, TKWHT21, W, TW)			STD
966-972	POWDER WHITE (N0006EA) REAR WHEELS/RIMS (PKWHT21, TKWHT21, W, TW)			STD
964-6Z7	BUMPER PAINT: FP24812 ARGENT SILVER DUPONT FLEX			STD
976-995	SUNVISOR PAINTED SAME AS CAB COLOR A			N/C
963-003	STANDARD E COAT/UNDERCOATING			STD

Certification / Compliance

996-001	U.S. FMVSS CERTIFICATION, EXCEPT SALES CABS AND GLIDER KITS			STD
---------	-------------------------------------------------------------	--	--	-----

Secondary Factory Options

998-001	CORPORATE PDI CENTER IN-SERVICE ONLY			N/C
---------	--------------------------------------	--	--	-----

Raw Performance Data

AE4-99D	CALC'D FRAME LENGTH - OVERALL : 293.9
AE8-99D	CALCULATED EFFECTIVE BACK OF CAB TO REAR SUSPENSION C/L (CA) : 123.38 in
AM6-99D	CALC'D SPACE AVAILABLE FOR DECKPLATE : 126.45 in

Sales Programs

NO SALES PROGRAMS HAVE BEEN SELECTED

TOTAL VEHICLE SUMMARY

Adjusted List Price

Adjusted List Price ** \$145,105.00

Weight Summary

	Weight Front	Weight Rear	Total Weight
Factory Weight*	7249 lbs	7351 lbs	14600 lbs
Total Weight*	7249 lbs	7351 lbs	14600 lbs



Prepared for:
 Mike Cheatham
 CALDWELL COUNTY
 110 S MAIN ST
 LOCKHART, TX 78644
 Phone: 512-398-7268

Prepared by:
 Kevin Beran
 FREIGHTLINER OF AUSTIN
 1701 SMITH ROAD
 AUSTIN, TX 78721
 Phone: 512-389-0000

ITEMS NOT INCLUDED IN ADJUSTED LIST PRICE

Other Factory Charges

RAG-020	CUMMINS TARIFF CHARGE - \$280	\$280.00
P73-2FT	STANDARD DESTINATION CHARGE	\$2,100.00

Extended Warranty

WAI-47H	CUM 2017 L9: HD1 MD DTY 5 YEARS / 100,000 MILES / 161,000 KM EXTENDED WARRANTY. FEX APPLIES	\$1,550.00
WAX-101	CUM 2017 L9: AT3 MD DTY 5 YEARS / 100,000 MILES / 161,000 KM AFTERTREATMENT. FEX APPLIES	\$540.00
WAK-252	ALLISON 3500 RDS SERIES TRANSMISSION EXTEND WARRANTY, 5 YEARS/UNLIMITED MILES FEX	\$583.00
WAG-011	TOWING: 2 YEARS/UNLIMITED MILES/KM EXTENDED TOWING COVERAGE \$550 CAP FEX APPLIES	\$400.00
	Currency Exchange Rate	1.0000
	Total Extended Warranty (Local Currency)	\$3,073.00

(+) Weights shown are estimates only.

If weight is critical, contact Customer Application Engineering.

(**) Prices shown do not include taxes, fees, etc... "Net Equipment Selling Price" is located on the Quotation Details Proposal Report.



Prepared for:
 Mike Cheatham
 CALDWELL COUNTY
 110 S MAIN ST
 LOCKHART, TX 78644
 Phone 512-398-7268

Prepared by:
 Kevin Beran
 FREIGHTLINER OF AUSTIN
 1701 SMITH ROAD
 AUSTIN, TX 78721
 Phone 512-389-0000

OPERATING SPEED

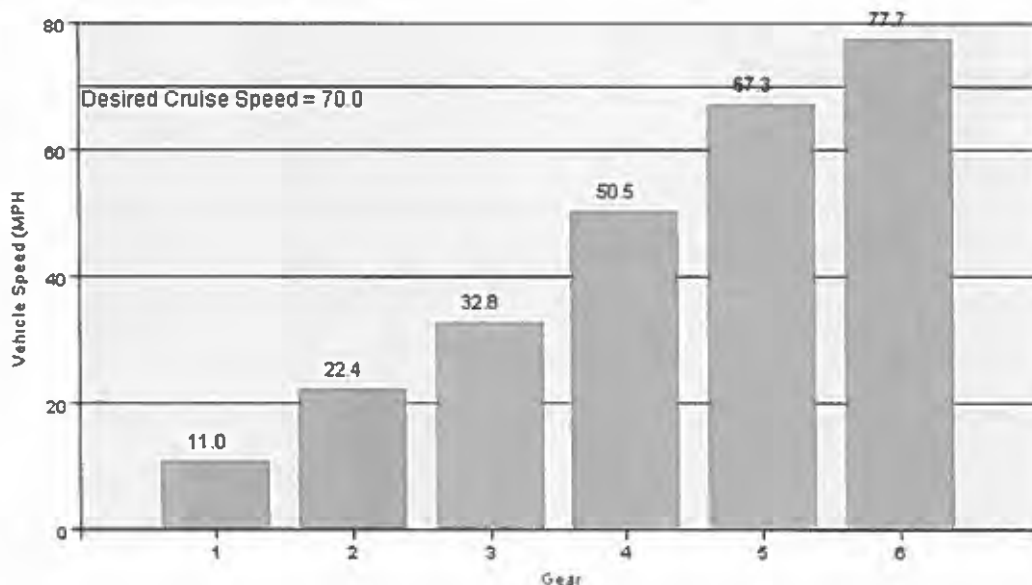

Rear Axle Ratio = 5.29

Engine RPM = 2200

VEHICLE SPECIFICATIONS SUMMARY - OPERATING SPEED

Model	M2106
Cab Size (829).....	106 INCH BBC FLAT ROOF ALUMINUM CONVENTIONAL CAB
Top Speed (mph).....	77.7
Engine RPM	2200.0
Desired Cruise Speed (mph).....	70.0
Engine (101).....	CUM L9 300 HP @ 2000 RPM, 2200 GOV RPM, 860 LB/FT @ 1300 RPM
Governed RPM	2200
Transmission (342).....	ALLISON 3500 RDS AUTOMATIC TRANSMISSION WITH PTO PROVISION
Rear Axle (420)	MT-40-14XP 40,000# R-SERIES TANDEM REAR AXLE



Prepared for:
 Mike Cheatham
 CALDWELL COUNTY
 110 S MAIN ST
 LOCKHART, TX 78644
 Phone: 512-398-7268

Prepared by:
 Kevin Beran
 FREIGHTLINER OF AUSTIN
 1701 SMITH ROAD
 AUSTIN, TX 78721
 Phone 512-389-0000

Number of Speeds..... 1
 Rear Axle Gear Ratio(s)..... 5.29 REAR AXLE RATIO
 Rear Tires (094) MICHELIN X MULTI D 11R22.5 16 PLY RADIAL REAR TIRES (NORTH AMERICAN ONLY)
 Revolutions per Mile 494
 Auxiliary Transmission (352)..... NO AUXILIARY TRANSMISSION
 High Gear Ratio..... N/A
 Low Gear Ratio..... N/A
 Transfer Case (373)..... NO TRANSFER CASE
 High Gear Ratio..... N/A
 Low Gear Ratio..... N/A

TABLE SUMMARY - OPERATING SPEED

Transmission Gear	Transmission Gear Ratio	Overall Gear Ratio	Vehicle Speed (MPH)
1	4.59	24.28	11.0
2	2.25	11.90	22.4
3	1.54	8.15	32.8
4	1.00	5.29	50.5
5	0.75	3.97	67.3
6	0.65	3.44	77.7
Desired Cruise Speed (mph)			70.0
Engine RPM			2200
Rear Axle Ratio			5.29
*Blue background represents value input by user			

Performance calculations are estimates only. If performance calculations are critical, please contact Customer Application Engineering.





Austin TX
 16870 South IH 35
 Buda, TX 78610
 512-312-1146

Customer Proposal Letter



CALDWELL COUNTY
 1105 MAIN STREET
 LOCKHART TX 78644
 (512) 227-1973

CALDWELL COUNTY Mike Warm, thank you for the opportunity to earn your business. We look forward to working with you on your business needs. Please accept the following proposal.

VEHICLE

Make Peterbilt Model 348 Year 2019 Stock Number 937688
 Additional Vehicle and Accessories Description _____ To be delivered on or about _____

	1	Total
Quantity	1	
Truck Price per Unit	\$106,527.00	\$106,527.00
F.E.T. (Factory & Dealer Paid)	\$10,656.00	\$10,656.00
Net Sales Price	\$117,183.00	\$117,183.00
Optional Extended Warranty(ies)		
State Sales Tax		
Documentary Fee	\$250.00	\$250.00
Administration Fee		
Vehicle Inventory Tax	\$230.52	\$230.52
Additional Taxes		
Tire Recycling Program		
Battery Disposal Fee		
Out of State Vehicle Fee		
Rebate(s)		
Total Sales Price (Including Rebate(s))	\$117,663.52	\$117,663.52
Trade Allowance (see DISCLAIMER Below)		\$0.00

*Hyd dump truck
with body*

Sales Representative

Purchaser

Accepted by Sales Manager or
 General Manager

signature

signature

title

signature

Ronnie Rose

printed name

printed name

date

printed name

Quote good until 5/13/2019

Note: The above Customer Proposal is a quotation only. Sale terms subject to approval of Sales Manager of Dealer.

DISCLAIMER: Any order based on this Proposal subject to Customer executing Dealer's standard form Retail Purchase Order incorporating above terms. Any documentary fees, state tax, title, registration and license fees subject to adjustment and change. Actual F.E.T. to be paid by Dealer, subject to adjustment. Any F.E.T. variance will be responsibility of Dealer. Manufacturer has reserved the right to change the price to Dealer of any vehicle not currently in Dealer's stock, without notice to Dealer. If Quoted Vehicle(s) not currently in Dealer's stock, Dealer reserves right to change Quotation Total to reflect any price increases from Manufacturer. This Proposal is based upon Dealer's current and expected inventory which is subject to change. Dealer not obligated to retail any specific vehicles in stock, nor maintain any specific inventory level. Dealer shall not be obligated to fulfill Proposal in event quoted vehicle(s) not in stock or available within requested delivery schedule at time Proposal accepted. Dealer shall not be liable for any delay in providing or inability to provide Quoted Vehicle(s), where such inability or delay is due, in whole or in part, to any cause beyond the reasonable control of Dealer or is without the gross negligence or intended misconduct of Dealer. Above listed Trade Value based upon current appraisal of Trade Vehicle(s). Dealer may adjust Trade Value of Trade Vehicle(s) to reflect changes in condition and/or mileage of Trade Vehicle(s) between date of current appraisal and acceptance of this Proposal by Customer.



Peterbilt Model 348



PRICED AT \$117,663.00

**2019 Peterbilt 348
PACCAR PX-9
350HP / 1150TQ
Allison 3000 RDS-P 6 Speed
Stock # 937688**

CONTACT INFO:

**RONNIE ROSE, SALES
Call: 512-312-1146
Toll Free: 888-243-6241
Local: 512-523-3200
Fax: 512-523-3137**

LOCATION:

**Austin
16870 S. IH-35
Buda, TX 78610**

HOURS:

**Monday-Friday: 7:30 am-7:00 pm
Saturday: 8:00 am-3:00 pm**

General

Unit Type New Medium Duty
Make Peterbilt
Model 348
Year 2019
Body Type Dump Body
Body Size 14.6
Body MFG Herrera
GVWR 54600
Stock Number 937688

Day Cab

Type Day Cab
BBC 108
Suspension Fixed
Interior Color Gray/Black

Exterior

Exterior Color WHITE
Liner Full frame rail steel

Engine

Engine MFG PACCAR
Engine Model PX-9
Horse Power 350hp
Torque 1150 lb-ft
Air Cleaner MFG Donaldson

Chassis

Wheel Base 190 inches

Tires and Wheels

Front Wheel Aluminum
Front Tire MFG Bridgestone

Front Tire Ply 16 Ply
Front Tire Size 22.5 inches
Rear Wheel Aluminum
Rear Tire MFG Bridgestone
Rear Tire Ply 14 Ply
Rear Tire Size 22.5 inches

Axle

Front Axle MFG Dana Spc
Front Axle Model E1462I
Front Axle Power Steering True
Front Axle Suspension TaperLeaf
Front Axle Suspension Weight 14,600 lbs
Front Axle Weight 14,600 lbs
Rear Axle MFG Dana Spc
Rear Axle Model DSP4I
Rear Axle Ratio 5.29
Rear Axle Suspension Air Trac
Rear Axle Weight 40,000 lbs

Transmission

Manufacturer Allison
Model 3000 RDS-P
Speed 6 Speed
Torque 1250 lb-ft

Fuel Tanks

Tank #1 Type Aluminum
Tank #1 Capacity 90 gallons
Tank #1 Size 26 in

Frame

Color Black
Rails 10 5/8 Steel

14 yd.

(4x)



14yd dump

Vanguard Truck Center of Austin

18001 N. HWY 35, Buda, TX 78610
Ph (512) 312-5400 Fax (512) 312-5440

New Vehicle Quotation Form

14yd dump

4/1/2019

(DATE)

CALDWELL COUNTY UNIT ROAD SYSTEMS

(PURCHASER)

1700 FM 2720

(ADDRESS)

LOCKHART, TX 78644

(CITY, STATE, ZIP)

DONALD LeCLERC

(Contact)

(512) 398-7269

(Telephone)

(Fax)

2019 MACK GR64F9

Sales Price	\$	<u>128,612.06</u>
Federal Retail Excise Tax	\$	<u>0.00</u>
Net Trade Allowance	(\$	<u>0.00)</u>
Sales Tax (Includes Emission Surcharge)	\$	<u>0.00</u>
Ad Valorem Tax	\$	<u>0.00</u>
License Fee: Type <u>STATE</u> Wt. _____	\$	<u>0.00</u>
Total Price	\$	<u>128,612.06</u>
Total Del. Price for <u>1</u> Vehicles	\$	<u>128,612.06</u>

VIN #	<u>TBD</u>
Engine	<u>CUMMINS ISL-D 350HP</u>
Transmission	<u>ALLISON 3000RDS 6-SPEED</u>
Fr. Axle	<u>MACK 20,000LB</u>
Rr. Axle	<u>MERITOR 46,000LB</u>
Suspension	<u>MACK 46,000LB AIR RIDE</u>
Ratio	<u>4.89</u>
Wheelbase	<u>243"</u>
Color	<u>WHITE</u>



Additional Comments:

INCLUDES:

14 FT SQUARE DUMP BODY INSTALLED

PINTLE HITCH FOR EQUIPMENT TRAILER

MANUAL TARPEN SYSTEM

HOT SHIFT PTO

Thank you for allowing me to quote your trucking needs!

JOHN WALSH



Vanguard Truck Center of Austin
NEW VEHICLE PURCHASE ORDER

4/1/2019
(DATE)

CALDWELL COUNTY UNIT ROAD SYSTEMS
(PURCHASER)

1700 FM 2720
(ADDRESS)

LOCKHART, TX 78644
(CITY, STATE, ZIP)

Telephone(s) (512) 398-7269

Fax Number

The undersigned Purchaser hereby orders from Vanguard Truck Center of Austin (hereinafter call the "Company")

1 New vehicle(s), Make MACK Model GR64F9 Year 2019 as described in the attached Specifications Covering Order for New Chassis VIN No. TBD. Said vehicle(s) are to be delivered on or about according to the following terms and conditions:

This order is Subject to the Price in Effect at the Time of Delivery. See Third to last Paragraph on Reverse Side Hereof.

Price per Vehicle \$ 128,612.06
Misc. Charges Des. \$ 0.00
Federal Retail Excise Tax \$ 0.00
Net Trade Allowance (\$ 0.00)
Sales Tax (Includes Emission Surcharge) \$ 0.00
Ad Valorem Tax \$ 0.00
Lic. Fee Type TATE ISSUE Wt. \$ 0.00
Total Price \$ 128,612.06
Total Price for 1 Vehicles \$ 128,612.06
Less Total Prepayment \$ 0.00
Balance of Purchase Price \$ 128,612.06

Table with Trade Calculations and Description of Trade sections. Trade Calculations includes Trade Value, Trade Payoff, and Net Trade Allowance, all at 0.00. Description of Trade includes Year, Make, Model, Vin#, and Mileage, all at 0.

THE COMPANY MAKES NO WARRANTIES AS TO SAID VEHICLE(S), EXPRESS, IMPLIED OR IMPLIED BY LAW, EXCEPT THE MANUFACTURER'S STANDARD VEHICLE WARRANTY, A COPY OF WHICH HAS BEEN DELIVERED TO THE PURCHASER, WHICH IS NOT INCORPORATED HEREIN BY REFERENCE. THE COMPANY SPECIFICALLY DISCLAIMS ANY IMPLIED WARRANTY OF MERCHANTABILITY OR FITNESS FOR A PARTICULAR PURPOSE. THE COMPANY SHALL NOT BE LIABLE FOR CONSEQUENTIAL DAMAGES, INCLUDING, BUT NOT LIMITED TO, LOSS OF INCOME. THE TERMS AND CONDITIONS ON THE REERSE SIDE HEREOF ARE A PART OF THIS AGREEMENT. THE PURCHASER ACKNOWLEDGES HAVING READ THIS AGREEMENT, INCLUDING SUCH TERMS AND CONDITIONS. ALL VEHICLES ARE SUBJECT TO PRIOR SALES. NO VEHICLES ARE HELD MORE THAN 5 DAYS WAITING FOR CREDIT APPROVAL.

Date 20

(SIGNATURE OF OFFICER, PARTNER OR OWNER WITH TITLE)

(SALES REPRESENTATIVE)

(APPROVED BY)

TERMS AND CONDITIONS

This purchase order is tendered by the Purchaser for acceptance by Vanguard Truck Center of Austin (hereinafter called the "Company"). It is understood that it will not be binding upon the Company unless accepted and signed by an authorized executive of the Company.

If the terms of payment herein provided are other than cash, the Purchaser agrees to execute and deliver to the Company, prior to the delivery of said vehicle(s), a security agreement, in the form customarily required by the Company, covering said vehicle(s) in order to secure the payment of the indebtedness due hereunder. The Purchaser further agrees that this purchase order shall be subject to all the terms and conditions of said security agreement, which shall supersede this purchase order to the extent inconsistent herewith; provided that Purchaser's warranty as to any used motor vehicle or equipment traded in by the Purchaser and taken by the Company as part of payment hereunder (hereinafter such used motor vehicle or equipment is called the "used equipment") shall survive the execution of the security agreement.

The Company shall not be held responsible for any loss, damage, detention, delay or failure to deliver resulting from any cause which is unavoidable or beyond its reasonable control, including, but not limited to fire, flood, natural disaster, strike or labor disturbance, accident, vandalism, riot or insurrection, war, any order, decree, law or regulation of any court, government or governmental agency, shortage of materials, demand in excess of available supply, failure or interruption of normal transportation or power facilities; NOR IN ANY EVENT SHALL THE COMPANY BE LIABLE FOR CONSEQUENTIAL DAMAGES, INCLUDING, BUT NOT LIMITED TO LOSS OF INCOME. The receipt of said vehicle(s) by the Purchaser upon delivery shall constitute a war waiver of all claims for loss or damage due to delay.

The Purchaser warrants that the used equipment, if any, is free from all liens and/or encumbrances of any nature whatsoever, and that the Purchaser has good and marketable title to the used equipment at the time of delivery thereof to the Company. The used equipment is to be delivered to the Company in the same condition and appearance in which it was when first inspected by the Company or its agent. The Company, upon delivery of such used equipment, shall have the right once again to inspect such used equipment and the Company shall be the sole judge as to its condition, with the right to accept or reject the used equipment at its option. If the used equipment to be delivered to the Company is not in a condition and appearance as good as it was when first inspected by the Company, the Company shall have the right to revalue the amount of allowance offered for such equipment and the total cash purchase price shall be increased accordingly.

The Purchaser agrees that the amount of the allowance made upon the used equipment, if any, is to be applied by the Company as part payment on the purchase price of said vehicle(s).

In the event that the within purchase order is accepted by the Company and the Purchaser fails to accept delivery and perform this contract pursuant to its terms, the Purchaser authorizes the Company to retain the amount paid to the Company in cash and/or the used equipment on account of the purchase price of said vehicle(s) as liquidated damages in addition to such rights as the Company may have under law.

In the event that the within purchase order is cancelled by mutual written agreement of the Company and the Purchaser or if the Company is unable to make delivery of said vehicle(s), the Company will return and the Purchaser will accept the cash and the used equipment (or if the used equipment shall have been sold, the net amount received by the Company from the sale thereof) in full discharge of any obligations of the Company to the Purchaser hereunder.

The Purchaser agrees that all previous communications between the Purchaser and the Company, either verbal or written, with reference to the subject matter of this purchase order, are hereby abrogated. The Purchaser further agrees that no modification of this Agreement shall be binding upon the Company unless such modifications shall be in writing and agreed to and accepted in writing by a Sales Manager or authorized Home Office executive of the Company.

A security interest in said vehicle(s) shall remain in the Company until the payment in full of the purchase price or, if the terms of payment herein provided are other than cash, until the execution and delivery of a security agreement, as hereinabove provided, at which time the terms of said security agreement shall control with respect to the title and ownership of said vehicle(s).

In the event of Purchaser's failure to make payment of the purchase price when due, the Company may take immediate possession of said vehicle(s), without demand or further notice. For this purpose and in furtherance thereof, the Purchaser shall, if the Company so requests, make said vehicle(s) available to the Company at a reasonably convenient place designated by it, and the Company shall have the right, and the Purchaser does hereby authorize and empower the Company, its agents, servants or employees, to enter upon the premises wherever said vehicle(s) may be and remove the same; and the Purchaser hereby expressly waives any action or right of action of any kind whatsoever against the Company, its agents, servants or employees because of the removal, repossession or retention of said vehicle(s) or otherwise.

If the cost to the Company of insurance to be furnished by the Company hereunder is increased at any time prior to the delivery of said vehicle(s), the Purchaser agrees to pay for the insurance herein provided for at such increased rate.

It is agreed that if the cost of labor, materials, body, accessories or other equipment or component parts increases beyond the basis upon which the price set forth herein was established, then the Company, at any time before delivery, may give the Purchaser written notice of an increase in price, and such increased price shall be the contract price, unless Purchaser within ten days thereafter shall give Company written notice of cancellation. Any such increase in the contract price, pursuant to this provision, however, shall not prevent additional increases, if necessary, under the circumstances set forth herein at any time prior to delivery.

ALL TAXES NOW OR HEREAFTER IMPOSED UPON THE MANUFACTURER OR SALE OF SAID VEHICLE(S) SHALL BE PAID BY THE PURCHASER.

This instrument contains the entire agreement between the parties, and there are no understandings or representations not contained herein.

Customer Initials _____

14yd ~~10~~ Dump trucks

RETAIL SALES ORDER
PRELIMINARY COPY

GRANDE TRUCK CENTER

INTERSTATE 10 AND W.W. WHITE ROAD
P.O. BOX 201210, SAN ANTONIO, TX 78220
PHONE: (210) 661-4121

PURCHASER'S NAME: **Caldwell County Unit Road** DEAL NO. _____ DATE: **1/21/2019**

ADDRESS: **1700 FM 2720**

CITY: **Lockhart** STATE: **TX** ZIP: **78644** PHONE: **512-227-1973**

STOCK NO.: **TBD**

PLEASE ENTER MY ORDER FOR THE FOLLOWING MOTOR VEHICLE:

YEAR	MAKE	MODEL	COLOR	W/B	I.D. NO.
2020	W. Star	4700	White	208	TBD

** The Dealer's Inventory Tax charge is intended to reimburse the dealer for ad valorem taxes on its motor vehicle inventory. The charge, which is paid by the dealer to the county tax assessor-collector, is not a tax imposed on a consumer by the government, and is not required to be charged by the dealer to the consumer.

New 2020 Western Star 4700 mounted with 14 yd. Ledwell Dump Body incl. Manual Tarp, Pintle Hitch, Chip Bar and Blue/Amber Beacons. Price includes Extended Warranty Packages

LIST PRICE:	\$	\$0.00
SALE PRICE	\$	\$123,924.00
ADDITIONAL EQUIPMENT	\$	\$0.00
SUB TOTAL	\$	\$123,924.00
FEDERAL EXCISE TAX	\$	\$0.00
**DEALER'S INVENTORY TAX	\$	\$295.93
LESS TRADE-IN ALLOWANCE	\$	\$0.00
NET DIFFERENCE		\$124,219.93
STATE & LOCAL TAXES	\$	\$0.00
LICENSE & BRIDGE FEES	\$	\$964.65
TITLE FEE	\$	\$33.00
STATE INSPECTION	\$	\$62.00
EXTENDED SERVICE PLAN	\$	\$13,237.00
MISC CHARGES	\$	\$0.00
DOCUMENTARY FEE	\$	\$125.00

\$138,641.58 x 4 = \$554,566.32

Cummins 9L Engine

USED VEHICLE MILES	IF SALE IS OF A USED VEHICLE, IT IS SOLD (BOUGHT) AS IS.	A DOCUMENTARY FEE IS NOT AN OFFICIAL FEE. A DOCUMENTARY FEE IS NOT REQUIRED BY LAW BUT MAY BE CHARGED TO BUYERS FOR HANDLING DOCUMENTS AND PERFORMING SERVICES RELATING TO THE CLOSING OF A SALE. A DOCUMENTARY FEE MAY NOT EXCEED \$300 OR A REASONABLE AMOUNT AGREED TO BY THE PARTIES FOR A HEAVY COMMERCIAL VEHICLE CONTRACT. THIS NOTICE IS REQUIRED BY LAW.	
DRAFT	\$	SUB TOTAL	\$138,641.58
LIEN TO		OWING TO:	\$0.00
		ON TRADE IN	
		AMOUNT DUE	\$138,641.58
Unpaid Balance - Amount Financed	\$	CASH DEPOSIT REC. #	Rebates \$0.00
		BALANCE DUE	\$138,641.58

PURCHASER AGREES THAT THIS ORDER INCLUDES ALL OF THE TERMS AND CONDITIONS ON BOTH THE FACE AND REVERSE SIDE HEREOF, THAT THIS ORDER CANCELS AND SUPERSEDES ANY PRIOR AGREEMENT AND AS OF THE DATE HEREOF COMPRISES THE COMPLETE AND EXCLUSIVE STATEMENT OF THE TERMS OF THE AGREEMENT RELATING TO THE SUBJECT BINDING UNTIL ACCEPTED BY THE GENERAL MANAGER OR SALES MANAGER PURCHASER BY HIS EXECUTION OF THIS ORDER ACKNOWLEDGES THAT HE HAS READ ITS TERMS AND CONDITIONS AND HAS RECEIVED A TRUE COPY OF THIS ORDER

IF SALE IS OF A USED VEHICLE, IT IS SOLD (BOUGHT) AS IS. THIS ORDER SHALL NOT BECOME BINDING UNTIL ACCEPTED BY THE GENERAL MANAGER OR SALES MANAGER

COMPANY NAME: **Caldwell County Unit Road** ACCEPTED & APPROVED: **Mike Unverzagt**

PURCHASER'S SIGNATURE: _____ SALESMAN: _____

RETAIL SALES ORDER

PRELIMINARY COPY

GRANDE TRUCK CENTER

INTERSTATE 10 AND W.W WHITE ROAD
P.O. BOX 201210, SAN ANTONIO, TX 78220
PHONE: (210) 661-4121



PURCHASER'S NAME Caldwell County Unit Road		DEAL NO	DATE 1/21/2019
ADDRESS 1700 FM 2720			STOCK NO TBD
CITY Lockhart	STATE TX	ZIP 78644	

PLEASE ENTER MY ORDER FOR THE FOLLOWING MOTOR VEHICLE					
YEAR 2020	MAKE W. Star	MODEL 4700	COLOR White	WB 208	ID NO TBD

<p>** The Dealer's Inventory Tax charge is intended to reimburse the dealer for ad valorem taxes on its motor vehicle inventory. The charge, which is paid by the dealer to the county tax assessor-collector, is not a tax imposed on a consumer by the government, and is not required to be charged by the dealer to the consumer.</p> <p>New 2020 Western Star 4700 mounted with 14 yd. Ledwell Dump Body incl. Manual Tarp, Pintle Hitch, Chip Bar and Blue/Amber Beacons.</p> <p>Price Includes Extended Warranty Packages</p> <p>#146,326.65 x 4 = #585,306.60</p> <p>Detroit 13L Engine</p>	LIST PRICE	\$	\$0.00	
	SALE PRICE	\$	\$129,489.00	
	ADDITIONAL EQUIPMENT	\$	\$0.00	
	SUB TOTAL	\$	\$129,489.00	
	FEDERAL EXCISE TAX	\$	\$0.00	
	**DEALER'S INVENTORY TAX	\$	\$0.00	
	LESS TRADE-IN ALLOWANCE	\$	\$0.00	
	YEAR	MAKE	LIC. NO	
	I.D. NO.			
	NET DIFFERENCE			\$129,489.00
STATE & LOCAL TAXES	\$	\$0.00		
LICENSE & BRIDGE FEES	\$	\$964.65		
TITLE FEE	\$	\$33.00		
STATE INSPECTION	\$	\$62.00		
EXTENDED SERVICE PLAN	\$	\$15,653.00		
MISC CHARGES	\$	\$0.00		
DOCUMENTARY FEE	\$	\$125.00		

USED VEHICLE MILES	A DOCUMENTARY FEE IS NOT AN OFFICIAL FEE. A DOCUMENTARY FEE IS NOT REQUIRED BY LAW BUT MAY BE CHARGED TO BUYERS FOR HANDLING DOCUMENTS AND PERFORMING SERVICES RELATING TO THE CLOSING OF A SALE. A DOCUMENTARY FEE MAY NOT EXCEED \$300 OR A REASONABLE AMOUNT AGREED TO BY THE PARTIES FOR A HEAVY COMMERCIAL VEHICLE CONTRACT. THIS NOTICE IS REQUIRED BY LAW.		
IF SALE IS OF A USED VEHICLE, IT IS SOLD (BOUGHT) AS IS.	SUB TOTAL \$ \$146,326.65		
DRAFT \$	OWING TO	\$	\$0.00
	ON		
	TRADE		
	IN		
	AMOUNT DUE		\$ \$146,326.65
	CASH DEPOSIT REC. #	Rebates	\$ \$0.00
Unpaid Balance - Amount Financed \$	BALANCE DUE		\$ \$146,326.65

PURCHASER AGREES THAT THIS ORDER INCLUDES ALL OF THE TERMS AND CONDITIONS ON BOTH THE FACE AND REVERSE SIDE HEREOF, THAT THIS ORDER CANCELS AND SUPERSEDES ANY PRIOR AGREEMENT AND AS OF THE DATE HEREOF COMPRISES THE COMPLETE AND EXCLUSIVE STATEMENT OF THE TERMS OF THE AGREEMENT RELATING TO THE SUBJECT BINDING UNTIL ACCEPTED BY THE GENERAL MANAGER OR SALES MANAGER PURCHASER BY HIS EXECUTION OF THIS ORDER ACKNOWLEDGES THAT HE HAS READ ITS TERMS AND CONDITIONS AND HAS RECEIVED A TRUE COPY OF THIS ORDER

IF SALE IS OF A USED VEHICLE, IT IS SOLD (BOUGHT) AS IS. THIS ORDER SHALL NOT BECOME BINDING UNTIL ACCEPTED BY THE GENERAL MANAGER OR SALES MANAGER

COMPANY NAME Caldwell County Unit Road	ACCEPTED & APPROVED
PURCHASER'S SIGNATURE	SALESMAN <i>Mike Unverzagt</i>

Unit Road Caldwell County

Michael
712 298 8199

From: kevin beran [REDACTED]
Sent: Monday, April 01, 2019 4:36 PM
To: unitroad@co.caldwell.tx.us
Subject: 2020-Freightliner M2-106 2,000 Gallon Water Truck-Spec & Quote
Attachments: Caldwell County-2000 Water Truck Chassis-Spec..docx; Caldwell County-(2020-M2-106 2,000 Gallon Water Truck).xls

Hello Mike,

Attached is the last truck to quote, for your Trucking needs!

The tank builder does not offer a liner option, but said the 3/16" material would hold up well, if you don't plan on hauling salt water in it.

Remember, that the \$400.00 buy board fee is per P.O. not per truck, with the exception of the trailers.

Any questions, feel free to give me a shout anytime.

If we get the business soon and can get the trucks all in the order bank, we should be able to get everything built and delivered before the end of the year.

Thanks again, for the opportunity to assist with your Trucking needs.

Have a GREAT day, ☺

Kevin Beran
Freightliner of Austin
512-619-5152- Cell Phone
512-389-0000- Office- Ext.104

water truck



FREIGHTLINER OF AUSTIN

INV #:

1701 Smith Rd.
Austin, Texas 78721Bus: 512-389-0000
Fax: 512-389-2663

BUYER'S ORDER

BUYER'S NAME CALDWELL COUNTY		TELEPHONE 512-398-7268	
ADDRESS 110 SOUTH MAIN ST.		CITY LOCKHART	STATE TX
YEAR 2020	MAKE FREIGHTLINER	MODEL/BODY M2-106 WATER TRUCK	LICENSE PLATE 78644

A DOCUMENTARY FEE IS NOT AN OFFICIAL FEE. A DOCUMENTARY FEE IS NOT REQUIRED BY LAW, BUT MAY CHARGED TO BUYER FOR HANDLING DOCUMENTS RELATING TO THE SALE. A DOCUMENTARY FEE MAY NOT EXCEED A REASONABLE AMOUNT AGREED TO BY THE PARTIES. THIS NOTICE IS REQUIRED BY LAW.

UN CARGO DOCUMENTAL NO ES UN CALGO OFFICIAL. LA LEY NO EXIGE QUE SE IMPONGA UN CARGO DOCUMENTAL. PERO ESTE PODRIA COBRARSE A LOS COMPRADORES POR EL MANEJO DE LA DOCUMENTACION EN RELACION CON LA VENTA. UN CARGO DOCUMENTAL NO PUEDE EXCEDER UNA CANTIDAD RAZONABLE ACORDADA POR LAS PARTES. ESTA NOTIFICACION SE EXIGE POR LEY.

Disclaimer of Warranties
The above described vehicle sold by Freightliner of Austin is sold as is, without either express or implied warranties of any kind. Freightliner of Austin, including warranties of merchantability, fitness, and Buyer will bear the entire expense of repairing or correcting any defects that presently exist or that may occur in the future. Freightliner of Austin covering the described vehicle is delivered as is, in conjunction with or within 90 days following the time of purchase, but such vehicle or any of its component parts may be subject to warranty by the manufacturer thereof.

MILEAGE:	
ORDER PROPOAL	
SELLING PRICE	\$93,500.00
INCLUDES:	
2,000 GALLON GRAVITY FLOW WATER TANK MOUNTED BY W2 MACFAB CO.	
BUY BOARD FEE	\$400.00
EXTENDED WARRANTY INFO. LISTED ON THE LAST PAGES OF THE DETAILED SPEC.	

MILEAGE:	MAKE	MODEL/BODY	VIN	
YEAR				
MILEAGE:	MAKE	MODEL/BODY	TRADE IN	VIN
YEAR				
PAYOFF TO:			TOTAL	\$93,900.00
ADDRESS:			(Trade Allowance)	
GOOD UNTIL:			TRADING DIFFERENCE	
QUOTED BY:			SALES TAX	N/A
SHOW LEIN TO:			DEALER'S INVENTORY TAX	N/A
ADDRESS:			LICENSE FEE	N/A
DATED:			DOCUMENTARY FEE	N/A
DRAFT FOR \$			FEDERAL EXCISE TAX	N/A
DRAFT THRU:			State Insp.:	TOTAL SALE PRICE
ADDRESS:			License:	\$93,900.00
			Title:	PAYOFF ON TRADE
			Transfer:	EXT. SERVICE AGREEMENT
				LESS DEPOSIT
			Total Balance Due	\$93,900.00

county tax assessor-collector, is not a tax imposed on a consumer by the government, and is not required to be charged by the dealer to the buyer. The information you see on the window form for this vehicle is part of this contract. Information on the window form overrides any contrary printed information. La informacion que aparece en la ventanilla de este vehiculo forma parte de este contrato. La informacion contenida en el formulario de la ventanilla anula cualquier informacion que aparece en el contrato de venta. If a credit purchase, this is an offer to purchase only. Buyer offers to purchase vehicle on credit term relationship is created. This order does not constitute an agreement for the extension of credit. Manufacturer/Distributor reserves the right to change the price of the vehicle in the event that the price to Seller of the new vehicle ordered hereunder is changed prior to delivery to Buyer. Buyer agrees and accepts that the cash delivered by Buyer for the used vehicle trade-in is not delivered to the Seller until delivery of the new vehicle, the trade-in will be reappraised at that time and Buyer agrees to determine the allowance, if any, made for the trade-in. Buyer agrees to deliver the original bill of sale and the title to an trade-in along with the delivery of the vehicle and all documents necessary or required to transfer legal title and ownership to Seller or its assigns. Buyer warrants the trade-in to be his property and free of liens, except as otherwise noted herein. Buyer further warrants that the trade-in has not been declared rebuilt salvage, reconditioned, nonrepairable, or flood damage and has not been tampered with and are in the condition as originally manufactured, except for ordinary wear, unless so disclosed. Seller makes no representations, warranties, or any information posted on the sale unit or contained in literature relating to the same reflect the results of tests performed, required or prescribed by government agencies. It is expressly agreed to and understood by Buyer and Seller that in the event of a non-credit transaction, Seller retains a security interest in the purchase price of the vehicle. Buyer agrees to all the above listed charges.

BUYER'S SIGNATURE: _____ SELLER'S SIGNATURE _____ DATE _____
AUSTIN TRUCK & EQUIPMENT, LTD. DBA FREIGHTLINER OF AUSTIN

Prepared for:
Mike Cheatham
CALDWELL COUNTY
110 S MAIN ST
LOCKHART, TX 78644
Phone: 512-398-7268

Prepared by:
Kevin Beran
FREIGHTLINER OF AUSTIN
1701 SMITH ROAD
AUSTIN, TX 78721
Phone: 512-389-0000

A proposal for
CALDWELL COUNTY

Prepared by
FREIGHTLINER OF AUSTIN
Kevin Beran

Apr 01, 2019

Freightliner M2 106

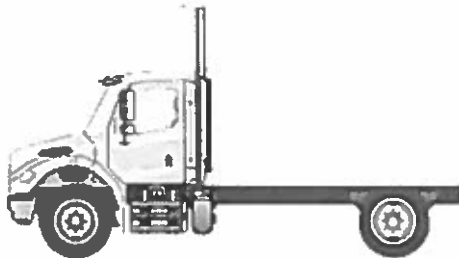

Components shown may not reflect all spec'd options and are not to scale



Prepared for:
 Mike Cheatham
 CALDWELL COUNTY
 110 S MAIN ST
 LOCKHART, TX 78644
 Phone: 512-398-7268

Prepared by:
 Kevin Beran
 FREIGHTLINER OF AUSTIN
 1701 SMITH ROAD
 AUSTIN, TX 78721
 Phone: 512-389-0000

S P E C I F I C A T I O N P R O P O S A L

Data Code	Description	Weight Front	Weight Rear	Retail Price
Price Level				
PRL-19M	M2 PRL-19M (EFF:01/15/19)			STD
Data Version				
DRL-012	SPECPRO21 DATA RELEASE VER 012			N/C
Vehicle Configuration				
001-172	M2 106 CONVENTIONAL CHASSIS	5,709	3,503	\$103,510.00
004-220	2020 MODEL YEAR SPECIFIED			STD
002-004	SET BACK AXLE - TRUCK			STD
019-002	STRAIGHT TRUCK PROVISION			STD
003-001	LH PRIMARY STEERING LOCATION			STD
General Service				
AA1-002	TRUCK CONFIGURATION			STD
AA6-002	DOMICILED, USA (EXCLUDING CALIFORNIA AND CARB OPT-IN STATES)			STD
A85-011	CONSTRUCTION SERVICE			N/C
A84-1GM	GOVERNMENT BUSINESS SEGMENT			N/C
AA4-002	LIQUID BULK COMMODITY			N/C
AA5-002	TERRAIN/DUTY: 100% (ALL) OF THE TIME, IN TRANSIT, IS SPENT ON PAVED ROADS			STD
AB1-008	MAXIMUM 8% EXPECTED GRADE			STD
AB5-001	SMOOTH CONCRETE OR ASPHALT PAVEMENT - MOST SEVERE IN-TRANSIT (BETWEEN SITES) ROAD SURFACE			STD
995-091	MEDIUM TRUCK WARRANTY			STD
A66-99D	EXPECTED FRONT AXLE(S) LOAD : 12000.0 lbs			
A68-99D	EXPECTED REAR DRIVE AXLE(S) LOAD : 21000.0 lbs			
A63-99D	EXPECTED GROSS VEHICLE WEIGHT CAPACITY : 33000.0 lbs			
Truck Service				
AA3-003	TANK BODY			N/C
A88-99D	EXPECTED TRUCK BODY LENGTH : 10.0 ft			



Prepared for:
 Mike Cheatham
 CALDWELL COUNTY
 110 S MAIN ST
 LOCKHART, TX 78644
 Phone: 512-398-7268

Prepared by:
 Kevin Beran
 FREIGHTLINER OF AUSTIN
 1701 SMITH ROAD
 AUSTIN, TX 78721
 Phone: 512-389-0000

Data Code	Description	Weight Front	Weight Rear	Retail Price
AF3-207	NIECE EQUIPMENT			N/C
AF7-99D	EXPECTED BODY/PAYLOAD CG HEIGHT ABOVE FRAME "XX" INCHES : 32.0 in			
Engine				
101-22N	CUM L9 270 HP @ 2000 RPM; 2200 GOV RPM, 800 LB/FT @ 1300 RPM	640	30	\$10,776.00
Electronic Parameters				
79A-078	78 MPH ROAD SPEED LIMIT			N/C
79B-000	CRUISE CONTROL SPEED LIMIT SAME AS ROAD SPEED LIMIT			N/C
79M-001	PTO MODE BRAKE OVERRIDE - SERVICE BRAKE APPLIED			N/C
79P-002	PTO RPM WITH CRUISE SET SWITCH - 700 RPM			N/C
79Q-003	PTO RPM WITH CRUISE RESUME SWITCH - 800 RPM			N/C
79S-001	PTO MODE CANCEL VEHICLE SPEED - 5 MPH			N/C
79U-007	PTO GOVERNOR RAMP RATE - 250 RPM PER SECOND			N/C
80G-002	PTO MINIMUM RPM - 700			N/C
80J-002	REGEN INHIBIT SPEED THRESHOLD - 5 MPH			N/C
Engine Equipment				
99C-017	2016 ONBOARD DIAGNOSTICS/2010 EPA/CARB/FINAL GHG17 CONFIGURATION			STD
99D-011	2008 CARB EMISSION CERTIFICATION - CLEAN IDLE (INCLUDES 6X4 INCH LABEL ON LOWER FORWARD CORNER OF DRIVER DOOR)			\$109.00
13E-001	STANDARD OIL PAN			STD
105-001	ENGINE MOUNTED OIL CHECK AND FILL			STD
133-004	ONE PIECE VALVE COVER			STD
014-1B5	SIDE OF HOOD AIR INTAKE WITH DONALDSON HIGH CAPACITY AIR CLEANER WITH SAFETY ELEMENT, FIREWALL MOUNTED			\$50.00
124-1D7	DR 12V 160 AMP 28-SI QUADRAMOUNT PAD ALTERNATOR WITH REMOTE BATTERY VOLT SENSE			STD
292-208	(2) DTNA GENUINE, FLOODED STARTING, MIN 2250CCA, 390RC, THREADED STUD BATTERIES			\$57.00
290-017	BATTERY BOX FRAME MOUNTED			STD
281-001	STANDARD BATTERY JUMPERS			STD
282-001	SINGLE BATTERY BOX FRAME MOUNTED LH SIDE UNDER CAB			STD



Prepared for:
 Mike Cheatham
 CALDWELL COUNTY
 110 S MAIN ST
 LOCKHART, TX 78644
 Phone: 512-398-7268

Prepared by:
 Kevin Beran
 FREIGHTLINER OF AUSTIN
 1701 SMITH ROAD
 AUSTIN, TX 78721
 Phone: 512-389-0000

Data Code	Description	Weight Front	Weight Rear	Retail Price
291-017	WIRE GROUND RETURN FOR BATTERY CABLES WITH ADDITIONAL FRAME GROUND RETURN			STD
289-001	NON-POLISHED BATTERY BOX COVER			STD
87P-998	NO CAB AUXILIARY POWER WIRING			STD
295-029	POSITIVE AND NEGATIVE POSTS FOR JUMPSTART LOCATED ON FRAME NEXT TO STARTER	2		\$92.00
107-032	CUMMINS TURBOCHARGED 18.7 CFM AIR COMPRESSOR WITH INTERNAL SAFETY VALVE			STD
108-002	STANDARD MECHANICAL AIR COMPRESSOR GOVERNOR			STD
131-013	AIR COMPRESSOR DISCHARGE LINE			STD
152-041	ELECTRONIC ENGINE INTEGRAL SHUTDOWN PROTECTION SYSTEM			STD
128-076	CUMMINS EXHAUST BRAKE INTEGRAL WITH VARIABLE GEOMETRY TURBO WITH ON/OFF DASH SWITCH	20		N/C
016-1C2	RH OUTBOARD UNDER STEP MOUNTED HORIZONTAL AFTERTREATMENT SYSTEM ASSEMBLY WITH RH B-PILLAR MOUNTED VERTICAL TAILPIPE	30	25	\$823.00
28F-002	ENGINE AFTERTREATMENT DEVICE, AUTOMATIC OVER THE ROAD REGENERATION AND DASH MOUNTED REGENERATION REQUEST SWITCH			STD
239-026	10 FOOT 06 INCH (126 INCH+0/-5.9 INCH) EXHAUST SYSTEM HEIGHT			(\$4.00)
237-1CR	RH CURVED VERTICAL TAILPIPE B-PILLAR MOUNTED ROUTED FROM STEP			N/C
23U-002	13 GALLON DIESEL EXHAUST FLUID TANK	35	10	\$105.00
30N-003	100 PERCENT DIESEL EXHAUST FLUID FILL			\$17.00
23Z-002	NON-POLISHED ALUMINUM DIESEL EXHAUST FLUID TANK COVER	15	5	\$144.00
43X-002	LH MEDIUM DUTY STANDARD DIESEL EXHAUST FLUID TANK LOCATION			STD
23Y-001	STANDARD DIESEL EXHAUST FLUID PUMP MOUNTING			STD
43Y-001	STANDARD DIESEL EXHAUST FLUID TANK CAP			STD
242-001	STAINLESS STEEL AFTERTREATMENT DEVICE/MUFFLER/TAILPIPE SHIELD			\$48.00
273-018	HORTON DRIVEMASTER ADVANTAGE ON/OFF FAN DRIVE			N/C
276-001	AUTOMATIC FAN CONTROL WITHOUT DASH SWITCH, NON ENGINE MOUNTED			STD
110-003	CUMMINS SPIN ON FUEL FILTER			STD



Prepared for:
 Mike Cheatham
 CALDWELL COUNTY
 110 S MAIN ST
 LOCKHART, TX 78644
 Phone: 512-398-7268

Prepared by:
 Kevin Beran
 FREIGHTLINER OF AUSTIN
 1701 SMITH ROAD
 AUSTIN, TX 78721
 Phone: 512-389-0000

Data Code	Description	Weight Front	Weight Rear	Retail Price
118-008	COMBINATION FULL FLOW/BYPASS OIL FILTER			N/C
120-009	FLEETGUARD PLAIN COOLANT FILTER			\$122.00
266-101	900 SQUARE INCH ALUMINUM RADIATOR	15		N/C
103-039	ANTIFREEZE TO -34F, OAT (NITRITE AND SILICATE FREE) EXTENDED LIFE COOLANT			STD
171-007	GATES BLUE STRIPE COOLANT HOSES OR EQUIVALENT			STD
172-001	CONSTANT TENSION HOSE CLAMPS FOR COOLANT HOSES			STD
270-016	RADIATOR DRAIN VALVE			STD
168-002	LOWER RADIATOR GUARD			STD
134-001	ALUMINUM FLYWHEEL HOUSING			STD
132-004	ELECTRIC GRID AIR INTAKE WARMER			STD
155-058	DELCO 12V 38MT HD STARTER WITH INTEGRATED MAGNETIC SWITCH			N/C

Transmission

342-584	ALLISON 3500 RDS AUTOMATIC TRANSMISSION WITH PTO PROVISION	200	60	\$6,711.00
---------	------------------------------------------------------------	-----	----	------------

Transmission Equipment

343-339	ALLISON VOCATIONAL PACKAGE 223 - AVAILABLE ON 3000/4000 PRODUCT FAMILIES WITH VOCATIONAL MODELS RDS, HS, MH AND TRV			N/C
84B-012	ALLISON VOCATIONAL RATING FOR ON/OFF HIGHWAY APPLICATIONS AVAILABLE WITH ALL PRODUCT FAMILIES			N/C
84C-023	PRIMARY MODE GEARS, LOWEST GEAR 1, START GEAR 1, HIGHEST GEAR 6, AVAILABLE FOR 3000/4000 PRODUCT FAMILIES ONLY			N/C
84D-023	SECONDARY MODE GEARS, LOWEST GEAR 1, START GEAR 1, HIGHEST GEAR 6, AVAILABLE FOR 3000/4000 PRODUCT FAMILIES ONLY			N/C
84E-000	PRIMARY SHIFT SCHEDULE RECOMMENDED BY DTNA AND ALLISON, THIS DEFINED BY ENGINE AND VOCATIONAL USAGE			STD
84F-000	SECONDARY SHIFT SCHEDULE RECOMMENDED BY DTNA AND ALLISON, THIS DEFINED BY ENGINE AND VOCATIONAL USAGE			STD
84G-000	PRIMARY SHIFT SPEED RECOMMENDED BY DTNA AND ALLISON, THIS DEFINED BY ENGINE AND VOCATIONAL USAGE			STD
84H-000	SECONDARY SHIFT SPEED RECOMMENDED BY DTNA AND ALLISON, THIS DEFINED BY ENGINE AND VOCATIONAL USAGE			STD



Prepared for:
 Mike Cheatham
 CALDWELL COUNTY
 110 S MAIN ST
 LOCKHART, TX 78644
 Phone: 512-398-7268

Prepared by:
 Kevin Beran
 FREIGHTLINER OF AUSTIN
 1701 SMITH ROAD
 AUSTIN, TX 78721
 Phone: 512-389-0000

Data Code	Description	Weight Front	Weight Rear	Retail Price
84J-000	ENGINE BRAKE RANGE PRESELECT RECOMMENDED BY DTNA AND ALLISON, THIS DEFINED BY ENGINE AND VOCATIONAL USAGE			STD
84K-000	ENGINE BRAKE RANGE ALTERNATE PRESELECT RECOMMENDED BY DTNA AND ALLISON, THIS DEFINED BY ENGINE AND VOCATIONAL USAGE			STD
84N-200	FUEL SENSE 2.0 DISABLED - MAXIMUM PERFORMANCE - TABLE BASED			STD
84U-000	DRIVER SWITCH INPUT - DEFAULT - NO SWITCHES			STD
353-066	VEHICLE INTERFACE WIRING CONNECTOR WITH BLUNT CUTS, AT END OF FRAME			\$62.00
34C-001	ELECTRONIC TRANSMISSION CUSTOMER ACCESS CONNECTOR FIREWALL MOUNTED			\$23.00
362-035	CUSTOMER INSTALLED CHELSEA 277 SERIES PTO			N/C
363-001	PTO MOUNTING, LH SIDE OF MAIN TRANSMISSION			N/C
341-018	MAGNETIC PLUGS, ENGINE DRAIN, TRANSMISSION DRAIN, AXLE(S) FILL AND DRAIN			STD
345-003	PUSH BUTTON ELECTRONIC SHIFT CONTROL, DASH MOUNTED			N/C
97G-004	TRANSMISSION PROGNOSTICS - ENABLED 2013			N/C
370-015	WATER TO OIL TRANSMISSION COOLER, IN RADIATOR END TANK			STD
346-003	TRANSMISSION OIL CHECK AND FILL WITH ELECTRONIC OIL LEVEL CHECK			N/C
35T-001	SYNTHETIC TRANSMISSION FLUID (TES-295 COMPLIANT)			STD

Front Axle and Equipment

400-1A6	DETROIT DA-F-12.0-3 12,000# FF1 71.5 KPI/3.74 DROP SINGLE FRONT AXLE			STD
402-020	MERITOR 15X4 Q+ CAM FRONT BRAKES			STD
403-002	NON-ASBESTOS FRONT BRAKE LINING			STD
419-023	CONMET CAST IRON FRONT BRAKE DRUMS			STD
409-006	FRONT OIL SEALS			STD
408-001	VENTED FRONT HUB CAPS WITH WINDOW, CENTER AND SIDE PLUGS - OIL			STD
416-022	STANDARD SPINDLE NUTS FOR ALL AXLES			STD
405-031	HALDEX AUTOMATIC FRONT SLACK ADJUSTERS WITH STAINLESS STEEL CLEVIS PINS			\$60.00



Prepared for:
 Mike Cheatham
 CALDWELL COUNTY
 110 S MAIN ST
 LOCKHART, TX 78644
 Phone: 512-398-7268

Prepared by:
 Kevin Beran
 FREIGHTLINER OF AUSTIN
 1701 SMITH ROAD
 AUSTIN, TX 78721
 Phone: 512-389-0000

Data Code	Description	Weight Front	Weight Rear	Retail Price
536-050	TRW THP-60 POWER STEERING			STD
539-003	POWER STEERING PUMP			STD
534-015	2 QUART SEE THROUGH POWER STEERING RESERVOIR			STD
40T-002	SYNTHETIC 75W-90 FRONT AXLE LUBE			\$14.00
Front Suspension				
620-1F0	12,000# DUAL TAPERLEAF FRONT SUSPENSION	42		\$57.00
619-005	MAINTENANCE FREE RUBBER BUSHINGS - FRONT SUSPENSION			STD
410-001	FRONT SHOCK ABSORBERS			STD
Rear Axle and Equipment				
420-1C8	DETROIT DA-RS-21.0-4 21,000# R-SERIES SINGLE REAR AXLE			STD
421-522	5.22 REAR AXLE RATIO			STD
424-003	IRON REAR AXLE CARRIER WITH OPTIONAL HEAVY DUTY AXLE HOUSING		20	\$79.00
386-073	MXL 17T MERITOR EXTENDED LUBE MAIN DRIVELINE WITH HALF ROUND YOKES	-20	-20	(\$411.00)
393-001	DRIVELINE GUARD	25	25	\$51.00
452-001	DRIVER CONTROLLED TRACTION DIFFERENTIAL - SINGLE REAR AXLE			\$734.00
878-018	(1) DRIVER CONTROLLED DIFFERENTIAL LOCK REAR VALVE FOR SINGLE DRIVE AXLE			N/C
87B-004	BLINKING LAMP WITH EACH MODE SWITCH, DIFFERENTIAL UNLOCK WITH IGNITION OFF, ACTIVE <5 MPH			N/C
423-020	MERITOR 16.5X7 Q+ CAST SPIDER CAM REAR BRAKES, DOUBLE ANCHOR, FABRICATED SHOES			STD
433-002	NON-ASBESTOS REAR BRAKE LINING			STD
434-005	BRAKE CAMS AND CHAMBERS ON FORWARD SIDE OF DRIVE AXLE(S) WITH AUXILIARY SUPPORT BRACKETS		2	\$24.00
451-023	CONMET CAST IRON REAR BRAKE DRUMS			STD
440-006	REAR OIL SEALS			STD
426-1B2	BENDIX EVERSURE LONGSTROKE 1-DRIVE AXLE SPRING PARKING CHAMBERS			\$23.00
428-031	HALDEX AUTOMATIC REAR SLACK ADJUSTERS WITH STAINLESS STEEL CLEVIS PINS			\$41.00
41T-002	SYNTHETIC 75W-90 REAR AXLE LUBE			STD

Rear Suspension



Prepared for:
 Mike Cheatham
 CALDWELL COUNTY
 110 S MAIN ST
 LOCKHART, TX 78644
 Phone: 512-398-7268

Prepared by:
 Kevin Beran
 FREIGHTLINER OF AUSTIN
 1701 SMITH ROAD
 AUSTIN, TX 78721
 Phone: 512-389-0000

Data Code	Description	Weight Front	Weight Rear	Retail Price
622-1MJ	23,000# 52 INCH VARIABLE RATE MULTI-LEAF SPRING REAR SUSPENSION WITH LEAF SPRING HELPER		110	(\$1,608.00)
621-001	SPRING SUSPENSION - NO AXLE SPACERS			N/C
431-001	STANDARD AXLE SEATS IN AXLE CLAMP GROUP			STD
439-001	REAR SHOCK ABSORBERS - ONE AXLE		40	\$173.00
Brake System				
018-002	AIR BRAKE PACKAGE			STD
490-101	WABCO 4S/4M ABS WITH TRACTION CONTROL, WITH ATC OFF-ROAD SWITCH			\$199.00
871-001	REINFORCED NYLON, FABRIC BRAID AND WIRE BRAID CHASSIS AIR LINES			STD
904-001	FIBER BRAID PARKING BRAKE HOSE			STD
412-001	STANDARD BRAKE SYSTEM VALVES			STD
46D-002	STANDARD AIR SYSTEM PRESSURE PROTECTION SYSTEM			STD
413-002	STD U.S. FRONT BRAKE VALVE			STD
432-003	RELAY VALVE WITH 5-8 PSI CRACK PRESSURE, NO REAR PROPORTIONING VALVE			STD
480-088	WABCO SYSTEM SAVER HP WITH INTEGRAL AIR GOVERNOR AND HEATER			STD
483-004	WABCO OIL COALESCING FILTER FOR AIR DRYER			\$11.00
479-012	AIR DRYER MOUNTED UNDER HOOD			N/C
460-001	STEEL AIR BRAKE RESERVOIRS			STD
607-001	CLEAR FRAME RAILS FROM BACK OF CAB TO FRONT REAR SUSPENSION BRACKET, BOTH RAILS OUTBOARD			\$63.00
477-006	BW DV-2 AUTO DRAIN VALVE WITHOUT HEATER ON ALL TANK(S)			\$82.00
Trailer Connections				
335-004	UPGRADED CHASSIS MULTIPLEXING UNIT			STD
32A-002	UPGRADED BULKHEAD MULTIPLEXING UNIT			STD
Wheelbase & Frame				
545-402	4025MM (158 INCH) WHEELBASE			N/C
546-100	1 1/32X3-1/2X10-3/16 INCH STEEL FRAME (8.73MMX258.8MM/0.344X10.19 INCH) 120KSI	-120	130	\$135.00
552-045	2025MM (80 INCH) REAR FRAME OVERHANG			N/C
55W-007	FRAME OVERHANG RANGE: 71 INCH TO 80 INCH	-20	90	N/C



Prepared for:
 Mike Cheatham
 CALDWELL COUNTY
 110 S MAIN ST
 LOCKHART, TX 78644
 Phone: 512-398-7268

Prepared by:
 Kevin Beran
 FREIGHTLINER OF AUSTIN
 1701 SMITH ROAD
 AUSTIN, TX 78721
 Phone: 512-389-0000

Data Code	Description	Weight Front	Weight Rear	Retail Price
AC8-99D	CALC'D BACK OF CAB TO REAR SUSP C/L (CA) : 92.91 in			
AE8-99D	CALCULATED EFFECTIVE BACK OF CAB TO REAR SUSPENSION C/L (CA) : 89.91 in			
AE4-99D	CALC'D FRAME LENGTH - OVERALL : 277.14			
FSS-0LH	CALCULATED FRAME SPACE LH SIDE : 28.57 in			N/C
FSS-0RH	CALCULATED FRAME SPACE RH SIDE : 162.4 in			N/C
AM6-99D	CALC'D SPACE AVAILABLE FOR DECKPLATE : 92.45 in			
553-001	SQUARE END OF FRAME			STD
550-001	FRONT CLOSING CROSSMEMBER			STD
559-001	STANDARD WEIGHT ENGINE CROSSMEMBER			STD
561-001	STANDARD CROSSMEMBER BACK OF TRANSMISSION			STD
562-001	STANDARD MIDSHIP #1 CROSSMEMBER(S)			STD
572-001	STANDARD REARMOST CROSSMEMBER			STD
565-001	STANDARD SUSPENSION CROSSMEMBER			STD
Chassis Equipment				
556-1AP	THREE-PIECE 14 INCH PAINTED STEEL BUMPER WITH COLLAPSIBLE ENDS	30		\$65.00
558-001	FRONT TOW HOOKS - FRAME MOUNTED	15		\$74.00
574-001	BUMPER MOUNTING FOR SINGLE LICENSE PLATE			STD
586-024	FENDER AND FRONT OF HOOD MOUNTED FRONT MUDFLAPS			STD
551-007	GRADE 8 THREADED HEX HEADED FRAME FASTENERS			STD
970-039	TANK BODY 1501 TO 3000 GALLONS			N/C
Fuel Tanks				
204-195	60 GALLON/227 LITER RECTANGULAR ALUMINUM FUEL TANK - LH	30		\$175.00
218-005	RECTANGULAR FUEL TANK(S)			STD
215-005	PLAIN ALUMINUM/PAINTED STEEL FUEL/HYDRAULIC TANK(S) WITH PAINTED BANDS			STD
212-007	FUEL TANK(S) FORWARD			STD
664-001	PLAIN STEP FINISH			STD
205-001	FUEL TANK CAP(S)			STD
122-1J1	DETROIT FUEL/WATER SEPARATOR WITH WATER IN FUEL SENSOR, HAND PRIMER AND 12 VOLT PREHEATER*	-5		\$59.00
216-020	EQUIFLO INBOARD FUEL SYSTEM			STD



Prepared for:
 Mike Cheatham
 CALDWELL COUNTY
 110 S MAIN ST
 LOCKHART, TX 78644
 Phone: 512-398-7268

Prepared by:
 Kevin Beran
 FREIGHTLINER OF AUSTIN
 1701 SMITH ROAD
 AUSTIN, TX 78721
 Phone: 512-389-0000

Data Code	Description	Weight Front	Weight Rear	Retail Price
11F-998	NO NATURAL GAS VEHICLE FUEL TANK VENT LINE/STACK			STD
202-016	HIGH TEMPERATURE REINFORCED NYLON FUEL LINE			STD
Tires				
093-1RK	MICHELIN X WORKS Z 11R22.5 16 PLY RADIAL FRONT TIRES	42		\$80.00
094-1UY	MICHELIN X MULTI D 11R22.5 16 PLY RADIAL REAR TIRES (NORTH AMERICAN ONLY)		60	(\$40.00)
Hubs				
418-060	CONMET PRESET PLUS PREMIUM IRON FRONT HUBS			STD
450-060	CONMET PRESET PLUS PREMIUM IRON REAR HUBS			STD
Wheels				
502-524	MAXION WHEELS 90541 22.5X8 25 10-HUB PILOT 6.20 INSET 2-HAND STEEL DISC FRONT WHEELS			N/C
505-524	MAXION WHEELS 90541 22.5X8 25 10-HUB PILOT 2-HAND STEEL DISC REAR WHEELS			N/C
496-011	FRONT WHEEL MOUNTING NUTS			STD
497-011	REAR WHEEL MOUNTING NUTS			STD
498-019	ALLIGATOR/V2B DUAL SEAL INFLATOR CAPS, FRONT AND REAR			\$24.00
Cab Exterior				
829-071	106 INCH BBC FLAT ROOF ALUMINUM CONVENTIONAL CAB			STD
650-008	AIR CAB MOUNTING			\$121.00
705-012	CAB ROOF REINFORCEMENTS FOR ROOF MOUNTED COMPONENTS	2		\$63.00
648-002	NONREMOVABLE BUGSCREEN MOUNTED BEHIND GRILLE			\$36.00
754-008	2-1/2 INCH FENDER EXTENSIONS	10		\$275.00
678-001	LH AND RH GRAB HANDLES			STD
646-045	MOLD-IN COLOR GRILLE			STD
65X-011	MOLD-IN COLOR HOOD MOUNTED AIR INTAKE GRILLE			STD
644-004	FIBERGLASS HOOD			STD
690-002	TUNNEL/FIREWALL LINER			\$35.00
727-1AF	SINGLE 14 INCH ROUND HADLEY AIR HORN UNDER LH DECK	4		\$82.00
726-001	SINGLE ELECTRIC HORN			STD



Prepared for:
 Mike Cheatham
 CALDWELL COUNTY
 110 S MAIN ST
 LOCKHART, TX 78644
 Phone: 512-398-7268

Prepared by:
 Kevin Beran
 FREIGHTLINER OF AUSTIN
 1701 SMITH ROAD
 AUSTIN, TX 78721
 Phone: 512-389-0000

Data Code	Description	Weight Front	Weight Rear	Retail Price
728-001	SINGLE HORN SHIELD			N/C
657-001	DOOR LOCKS AND IGNITION SWITCH KEYED THE SAME			STD
575-001	REAR LICENSE PLATE MOUNT END OF FRAME			STD
312-043	INTEGRAL HEADLIGHT/MARKER ASSEMBLY			STD
302-047	LED AERODYNAMIC MARKER LIGHTS			\$34.00
294-042	FREIGHTLINER LED FLANGE MOUNTED STOP/TAIL/TURN LIGHTS WITH SEPARATE INCANDESCENT BACKUP LIGHTS		5	\$107.00
300-015	STANDARD FRONT TURN SIGNAL LAMPS			STD
744-1BH	DUAL WEST COAST MOLDED-IN COLOR MIRRORS			STD
797-001	DOOR MOUNTED MIRRORS			STD
796-001	102 INCH EQUIPMENT WIDTH			STD
74A-001	RH DOWN VIEW MIRROR			\$24.00
729-001	STANDARD SIDE/REAR REFLECTORS			STD
677-016	DUAL LEVEL CAB ENTRY STEPS ON BOTH SIDES			N/C
764-010	COMPOSITE EXTERIOR SUN VISOR	10		\$280.00
768-043	63X14 INCH TINTED REAR WINDOW			STD
661-004	TINTED DOOR GLASS LH AND RH WITH TINTED OPERATING WING WINDOWS			\$130.00
654-003	MANUAL DOOR WINDOW REGULATORS			STD
663-013	TINTED WINDSHIELD			STD
659-019	2 GALLON WINDSHIELD WASHER RESERVOIR WITHOUT FLUID LEVEL INDICATOR, FRAME MOUNTED			STD

Cab interior

707-1AK	OPAL GRAY VINYL INTERIOR			N/C
706-026	MOLDED PLASTIC DOOR PANEL WITHOUT VINYL INSERT WITH ALUMINUM KICKPLATE LOWER DOOR			\$13.00
708-026	MOLDED PLASTIC DOOR PANEL WITHOUT VINYL INSERT WITH ALUMINUM KICKPLATE LOWER DOOR			\$26.00
772-006	BLACK MATS WITH SINGLE INSULATION			STD
785-001	DASH MOUNTED ASH TRAYS AND LIGHTER			\$13.00
691-008	FORWARD ROOF MOUNTED CONSOLE WITH UPPER STORAGE COMPARTMENTS WITHOUT NETTING			STD
694-010	IN DASH STORAGE BIN			STD
696-012	CENTER STORAGE CONSOLE MOUNTED ON BACKWALL	20		\$26.00



Prepared for:
 Mike Cheatham
 CALDWELL COUNTY
 110 S MAIN ST
 LOCKHART, TX 78644
 Phone: 512-398-7268

Prepared by:
 Kevin Beran
 FREIGHTLINER OF AUSTIN
 1701 SMITH ROAD
 AUSTIN, TX 78721
 Phone: 512-389-0000

Data Code	Description	Weight Front	Weight Rear	Retail Price
742-007	(2) CUP HOLDERS LH AND RH DASH			STD
680-006	GRAY/CHARCOAL FLAT DASH			STD
720-003	5 LB. FIRE EXTINGUISHER	10		\$60.00
700-002	HEATER, DEFROSTER AND AIR CONDITIONER			STD
701-001	STANDARD HVAC DUCTING			STD
703-005	MAIN HVAC CONTROLS WITH RECIRCULATION SWITCH			STD
170-015	STANDARD HEATER PLUMBING			STD
130-041	VALEO HEAVY DUTY A/C REFRIGERANT COMPRESSOR			STD
702-002	BINARY CONTROL, R-134A			STD
739-033	STANDARD INSULATION			STD
285-027	SOLID-STATE CIRCUIT PROTECTION AND FUSES WITH SPARE FUSE KIT			\$33.00
280-007	12V NEGATIVE GROUND ELECTRICAL SYSTEM			STD
324-014	DOME LIGHT WITH 3-WAY SWITCH ACTIVATED BY LH AND RH DOORS			STD
655-001	CAB DOOR LATCHES WITH MANUAL DOOR LOCKS			STD
284-023	(1) 12 VOLT POWER SUPPLY IN DASH			\$21.00
722-028	TRIANGULAR REFLECTORS KIT WITHOUT FLARES SHIPPED LOOSE IN CAB	10		\$24.00
756-1J3	BASIC HIGH BACK AIR SUSPENSION DRIVER SEAT WITH MECHANICAL LUMBAR AND INTEGRATED CUSHION EXTENSION	30		\$212.00
760-1DC	BASIC HIGH BACK NON SUSPENSION PASSENGER SEAT			STD
759-007	DUAL DRIVER SEAT ARMRESTS, NO PASSENGER SEAT ARMRESTS	4		\$69.00
711-004	LH AND RH INTEGRAL DOOR PANEL ARMRESTS			STD
758-014	BLACK CORDURA PLUS CLOTH DRIVER SEAT COVER			\$2.00
761-014	BLACK CORDURA PLUS CLOTH PASSENGER SEAT COVER			\$4.00
763-101	BLACK SEAT BELTS			STD
532-001	FIXED STEERING COLUMN			STD
540-016	18 INCH (450MM) LEATHER WRAPPED STEERING WHEEL			\$102.00
765-002	DRIVER AND PASSENGER INTERIOR SUN VISORS			STD

Instruments & Controls

732-004	GRAY DRIVER INSTRUMENT PANEL			STD
---------	------------------------------	--	--	-----



Prepared for:
 Mike Cheatham
 CALDWELL COUNTY
 110 S MAIN ST
 LOCKHART, TX 78644
 Phone: 512-398-7268

Prepared by:
 Kevin Beran
 FREIGHTLINER OF AUSTIN
 1701 SMITH ROAD
 AUSTIN, TX 78721
 Phone: 512-389-0000

Data Code	Description	Weight Front	Weight Rear	Retail Price
734-004	GRAY CENTER INSTRUMENT PANEL			STD
870-001	BLACK GAUGE BEZELS			STD
486-001	LOW AIR PRESSURE INDICATOR LIGHT AND AUDIBLE ALARM			STD
840-002	2 INCH PRIMARY AND SECONDARY AIR PRESSURE GAUGES			STD
198-003	DASH MOUNTED AIR RESTRICTION INDICATOR WITH GRADUATIONS			\$36.00
721-001	97 DB BACKUP ALARM		3	\$44.00
149-013	ELECTRONIC CRUISE CONTROL WITH SWITCHES IN LH SWITCH PANEL			STD
156-007	KEY OPERATED IGNITION SWITCH AND INTEGRAL START POSITION; 4 POSITION OFF/RUN/START/ACCESSORY			STD
811-042	ICU3S, 132X48 DISPLAY WITH DIAGNOSTICS, 28 LED WARNING LAMPS AND DATA LINKED			STD
160-038	HEAVY DUTY ONBOARD DIAGNOSTICS INTERFACE CONNECTOR LOCATED BELOW LH DASH			STD
844-001	2 INCH ELECTRIC FUEL GAUGE			STD
148-003	PROGRAMMABLE RPM CONTROL - ELECTRONIC ENGINE			STD
856-001	ELECTRICAL ENGINE COOLANT TEMPERATURE GAUGE			STD
864-001	2 INCH TRANSMISSION OIL TEMPERATURE GAUGE			STD
830-017	ENGINE AND TRIP HOUR METERS INTEGRAL WITHIN DRIVER DISPLAY			STD
372-051	CUSTOMER FURNISHED AND INSTALLED PTO CONTROLS			N/C
852-002	ELECTRIC ENGINE OIL PRESSURE GAUGE			STD
746-114	AM/FM/WB WORLD TUNER RADIO WITH AUXILIARY INPUT, J1939	10		\$290.00
747-001	DASH MOUNTED RADIO			N/C
750-002	(2) RADIO SPEAKERS IN CAB			N/C
753-001	AM/FM ANTENNA MOUNTED ON FORWARD LH ROOF			N/C
810-027	ELECTRONIC MPH SPEEDOMETER WITH SECONDARY KPH SCALE, WITHOUT ODOMETER			STD
817-001	STANDARD VEHICLE SPEED SENSOR			STD
812-001	ELECTRONIC 3000 RPM TACHOMETER			STD
162-011	IDLE LIMITER, ELECTRONIC ENGINE			STD



Prepared for:
 Mike Cheatham
 CALDWELL COUNTY
 110 S MAIN ST
 LOCKHART, TX 78644
 Phone: 512-398-7268

Prepared by:
 Kevin Beran
 FREIGHTLINER OF AUSTIN
 1701 SMITH ROAD
 AUSTIN, TX 78721
 Phone: 512-389-0000

Data Code	Description	Weight Front	Weight Rear	Retail Price
329-015	ONE ON/OFF ROCKER SWITCH IN THE DASH WITH INDICATOR LIGHT AND WIRE ROUTED TO CHASSIS AT BACK OF CAB, LABEL OPT			\$33.00
81Y-001	PRE-TRIP LAMP INSPECTION, ALL OUTPUTS FLASH, WITH SMART SWITCH			\$12.00
836-015	DIGITAL VOLTAGE DISPLAY INTEGRAL WITH DRIVER DISPLAY			STD
660-008	SINGLE ELECTRIC WINDSHIELD WIPER MOTOR WITH DELAY			STD
304-001	MARKER LIGHT SWITCH INTEGRAL WITH HEADLIGHT SWITCH			STD
882-018	ONE VALVE PARKING BRAKE SYSTEM WITH DASH VALVE CONTROL AUTONEUTRAL AND WARNING INDICATOR			\$111.00
299-013	SELF CANCELING TURN SIGNAL SWITCH WITH DIMMER, WASHER/WIPER AND HAZARD IN HANDLE			STD
298-039	INTEGRAL ELECTRONIC TURN SIGNAL FLASHER WITH HAZARD LAMPS OVERRIDING STOP LAMPS			STD

Design

065-000	PAINT: ONE SOLID COLOR			STD
---------	------------------------	--	--	-----

Color

980-5F6	CAB COLOR A: L0006EB WHITE ELITE BC			STD
986-020	BLACK, HIGH SOLIDS POLYURETHANE CHASSIS PAINT			STD
962-972	POWDER WHITE (N0006EA) FRONT WHEELS/RIMS (PKWHT21, TKWHT21, W, TW)			STD
966-972	POWDER WHITE (N0006EA) REAR WHEELS/RIMS (PKWHT21, TKWHT21, W, TW)			STD
964-6Z7	BUMPER PAINT: FP24812 ARGENT SILVER DUPONT FLEX			STD
976-995	SUNVISOR PAINTED SAME AS CAB COLOR A			N/C
963-003	STANDARD E COAT/UNDERCOATING			STD

Certification / Compliance

996-001	U.S. FMVSS CERTIFICATION, EXCEPT SALES CABS AND GLIDER KITS			STD
---------	-------------------------------------------------------------	--	--	-----

Secondary Factory Options

998-001	CORPORATE PDI CENTER IN-SERVICE ONLY			N/C
---------	--------------------------------------	--	--	-----

Raw Performance Data

AE4-99D	CALC'D FRAME LENGTH - OVERALL : 277.14			
---------	----------------------------------------	--	--	--



Prepared for:
 Mike Cheatham
 CALDWELL COUNTY
 110 S MAIN ST
 LOCKHART, TX 78644
 Phone: 512-398-7268

Prepared by:
 Kevin Beran
 FREIGHTLINER OF AUSTIN
 1701 SMITH ROAD
 AUSTIN, TX 78721
 Phone: 512-389-0000

Data Code	Description	Weight Front	Weight Rear	Retail Price
AE8-99D	CALCULATED EFFECTIVE BACK OF CAB TO REAR SUSPENSION C/L (CA) : 89.91 in			
AM6-99D	CALC'D SPACE AVAILABLE FOR DECKPLATE : 92.45 in			

Sales Programs

NO SALES PROGRAMS HAVE BEEN SELECTED

TOTAL VEHICLE SUMMARY

Adjusted List Price

Adjusted List Price ** \$125,127.00

Weight Summary

	Weight Front	Weight Rear	Total Weight
Factory Weight ⁺	6795 lbs	4098 lbs	10893 lbs
Total Weight ⁺	6795 lbs	4098 lbs	10893 lbs

ITEMS NOT INCLUDED IN ADJUSTED LIST PRICE

Other Factory Charges

RAG-020	CUMMINS TARIFF CHARGE - \$205	\$205.00
P73-2FT	STANDARD DESTINATION CHARGE	\$2,200.00

Extended Warranty

WAI-47H	CUM 2017 L9: HD1 MD DTY 5 YEARS / 100,000 MILES / 161,000 KM EXTENDED WARRANTY, FEX APPLIES	\$1,550.00
WAX-101	CUM 2017 L9: AT3 MD DTY 5 YEARS / 100,000 MILES / 161,000 KM AFTERTREATMENT. FEX APPLIES	\$540.00



Prepared for:
Mike Cheatham
CALDWELL COUNTY
110 S MAIN ST
LOCKHART, TX 78644
Phone: 512-398-7268

Prepared by:
Kevin Beran
FREIGHTLINER OF AUSTIN
1701 SMITH ROAD
AUSTIN, TX 78721
Phone: 512-389-0000

WAK-252	ALLISON 3500 RDS SERIES TRANSMISSION EXTEND WARRANTY, 5 YEARS/UNLIMITED MILES FEX	\$583.00
WAG-011	TOWING: 2 YEARS/UNLIMITED MILES/KM EXTENDED TOWING COVERAGE \$550 CAP FEX APPLIES	\$400.00
	Currency Exchange Rate	1.0000
	Total Extended Warranty (Local Currency)	\$3,073.00

(+) Weights shown are estimates only.

If weight is critical, contact Customer Application Engineering.

(**) Prices shown do not include taxes, fees, etc... "Net Equipment Selling Price" is located on the Quotation Details Proposal Report.



Prepared for:
 Mike Cheatham
 CALDWELL COUNTY
 110 S MAIN ST
 LOCKHART, TX 78644
 Phone 512-398-7268

Prepared by:
 Kevin Beran
 FREIGHTLINER OF AUSTIN
 1701 SMITH ROAD
 AUSTIN, TX 78721
 Phone 512-389-0000

D I M E N S I O N S

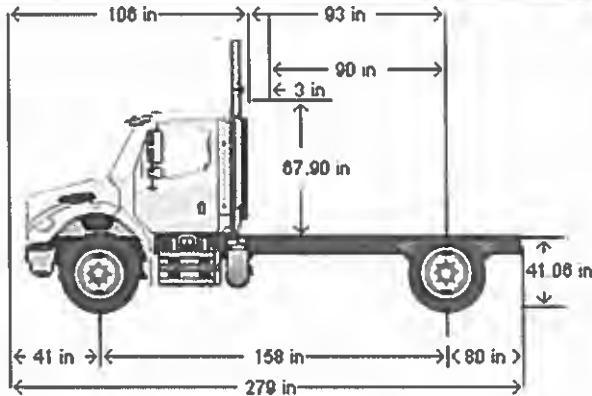

VEHICLE SPECIFICATIONS SUMMARY - DIMENSIONS

Model	M2106
Wheelbase (545)	4025MM (158 INCH) WHEELBASE
Rear Frame Overhang (552)	2025MM (80 INCH) REAR FRAME OVERHANG
Fifth Wheel (578)	NO FIFTH WHEEL
Mounting Location (577)	NO FIFTH WHEEL LOCATION
Maximum Forward Position (in)	0
Maximum Rearward Position (in)	0
Amount of Slide Travel (in)	0
Slide Increment (in)	0
Desired Slide Position (in)	0.0
Cab Size (829)	106 INCH BBC FLAT ROOF ALUMINUM CONVENTIONAL CAB
Sleeper (682)	NO SLEEPER BOX/SLEEPER CAB
Exhaust System (016)	RH OUTBOARD UNDER STEP MOUNTED HORIZONTAL AFTERTREATMENT SYSTEM ASSEMBLY WITH RH B-PILLAR MOUNTED VERTICAL TAILPIPE

TABLE SUMMARY - DIMENSIONS



Prepared for:
 Mike Cheatham
 CALDWELL COUNTY
 110 S MAIN ST
 LOCKHART, TX 78644
 Phone: 512-398-7268

Prepared by:
 Kevin Beran
 FREIGHTLINER OF AUSTIN
 1701 SMITH ROAD
 AUSTIN, TX 78721
 Phone: 512-389-0000

Dimensions	Inches
Bumper to Back of Cab (BBC)	106.3
Bumper to Centerline of Front Axle (BA)	40.7
Min. Cab to Body Clearance (CB)	3.0
Back of Cab to Centerline of Rear Axle(s) (CA)	92.9
Effective Back of Cab to Centerline of Rear Axle(s) (Effective CA)	89.9
Back of Cab Protrusions (Exhaust/Intake) (CP)	3.0
Back of Cab Protrusions (Side Extenders/Trim Tab) (CP)	0.0
Back of Cab Protrusions (CNG Tank)	0.0
Back of Cab Clearance (CL)	3.0
Back of Cab to End of Frame	172.6
Cab Height (CH)	67.9
Wheelbase (WB)	158.5
Frame Overhang (OH)	80.0
Overall Length (OAL)	278.9
Rear Axle Spacing	0.0
Unladen Frame Height at Centerline of Rear Axle	41.1

Performance calculations are estimates only. If performance calculations are critical, please contact Customer Application Engineering.



Prepared for:
 Mike Cheatham
 CALDWELL COUNTY
 110 S MAIN ST
 LOCKHART, TX 78644
 Phone: 512-398-7268

Prepared by:
 Kevin Beran
 FREIGHTLINER OF AUSTIN
 1701 SMITH ROAD
 AUSTIN, TX 78721
 Phone: 512-389-0000

OPERATING RANGE

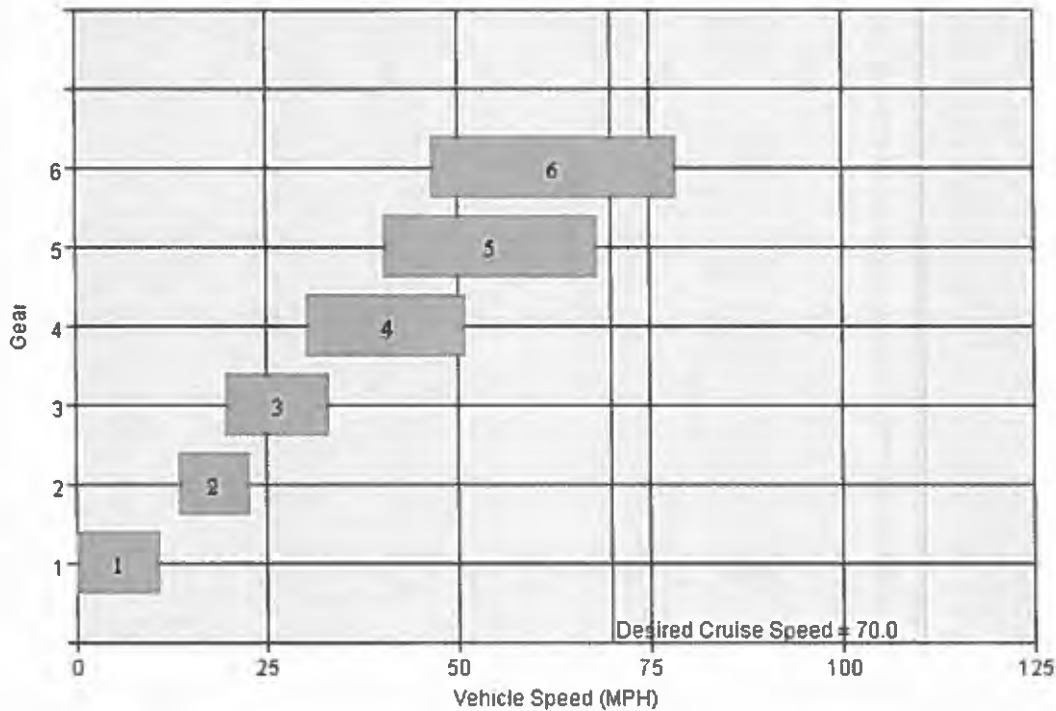

VEHICLE SPECIFICATIONS SUMMARY - OPERATING RANGE

Model	M2106
Cab Size (829).....	106 INCH BBC FLAT ROOF ALUMINUM CONVENTIONAL CAB
Desired Cruise Speed (mph).....	70.0
Engine (101).....	CUM L9 270 HP @ 2000 RPM; 2200 GOV RPM, 800 LB/FT @ 1300 RPM
RPM at Peak Torque	1300
Governed RPM	2200
Transmission (342).....	ALLISON 3500 RDS AUTOMATIC TRANSMISSION WITH PTO PROVISION
Gear Ratio: LL	N/A
Gear Ratio: L	N/A



Prepared for:
 Mike Cheatham
 CALDWELL COUNTY
 110 S MAIN ST
 LOCKHART, TX 78644
 Phone: 512-398-7268

Prepared by:
 Kevin Beran
 FREIGHTLINER OF AUSTIN
 1701 SMITH ROAD
 AUSTIN, TX 78721
 Phone: 512-389-0000

Gear Ratio: 1	4.59
Gear Ratio: 2	2.25
Gear Ratio: 3	1.54
Gear Ratio: 4	1
Gear Ratio: 5	0.75
Gear Ratio: 6	0.65
Gear Ratio: 7	N/A
Gear Ratio: 8	N/A
Gear Ratio: 9	N/A
Gear Ratio: 10	N/A
Gear Ratio: 11	N/A
Gear Ratio: 12	N/A
Gear Ratio: 13	N/A
Gear Ratio: 14	N/A
Gear Ratio: 15	N/A
Gear Ratio: 16	N/A
Gear Ratio: 17	N/A
Gear Ratio: 18	N/A
Auxiliary Transmission (352)	NO AUXILIARY TRANSMISSION
Low Gear Ratio	N/A
High Gear Ratio	N/A
Transfer Case (373)	NO TRANSFER CASE
Low Gear Ratio	N/A
High Gear Ratio	N/A
Rear Axle (420)	DETROIT DA-RS-21.0-4 21,000# R-SERIES SINGLE REAR AXLE
Number of Speeds	1
Rear Axle Gear Ratio(s)	5.22 REAR AXLE RATIO
Rear Tires (094)	MICHELIN X MULTI D 11R22.5 16 PLY RADIAL REAR TIRES (NORTH AMERICAN ONLY)
Revolutions per Mile	494

TABLE SUMMARY - OPERATING RANGE

Transmission Gear	Transmission Gear Ratio	Rear Axle Ratio	Overall Gear Ratio	Minimum Speed (MPH)	Maximum Speed (MPH)
1	4.59	5.22	23.96	0	11.2
2	2.25	5.22	11.74	13.4	22.8
3	1.54	5.22	8.04	19.6	33.2
4	1.00	5.22	5.22	30.2	51.2
5	0.75	5.22	3.92	40.3	68.3
6	0.65	5.22	3.39	46.5	78.8

Performance calculations are estimates only. If performance calculations are critical, please contact Customer Application Engineering.





Austin TX
 16870 South IH 35
 Buda TX 78610
 512-312-1146

Customer Proposal Letter

CALDWELL COUNTY
 1105 MAIN STREET
 LOCKHART, TX 78644
 (512) 227-1973

CALDWELL COUNTY Mike Warm, thank you for the opportunity to earn your business. We look forward to working with you on your business needs. Please accept the following proposal.

VEHICLE

Make Hino Model 268A Year 2018 Stock Number 830348
 Additional Vehicle and Accessories Description To be delivered on or about _____

2K Water Truck

Quantity	1	Total
Truck Price per Unit	\$93,000.00	\$93,000.00
F.E.T. (Factory & Dealer Paid)	\$0.00	\$0.00
Net Sales Price	\$93,000.00	\$93,000.00
Optional Extended Warranty(ies)		
State Sales Tax		
Documentary Fee	\$250.00	\$250.00
Administration Fee		
Vehicle Inventory Tax	\$201.25	\$201.25
Additional Taxes		
Tire Recycling Program		
Battery Disposal Fee		
Out of State Vehicle Fee		
Rebate(s)		
Total Sales Price (Including Rebate(s))	\$93,451.25	\$93,451.25
Trade Allowance (see DISCLAIMER Below)		\$0.00

Sales Representative

Ronnie Rose

Purchaser

signature

printed name

signature

printed name

title

date

Accepted by Sales Manager or General Manager

signature

printed name

Quote good until 5/13/2019

Note: The above Customer Proposal is a quotation only. Sale terms subject to approval of Sales Manager of Dealer.

DISCLAIMER: Any order based on this Proposal subject to Customer executing Dealer's standard form Retail Purchase Order incorporating above terms. Any documentary fees, state tax, title, registration and license fees subject to adjustment and change. Actual F.E.T. to be paid by Dealer, subject to adjustment. Any F.E.T. variance will be responsibility of Dealer. Manufacturer has reserved the right to change the price of Dealer of any vehicle not currently in Dealer's stock, without notice to Dealer. If Quoted Vehicle(s) not currently in Dealer's stock, Dealer reserves right to change Quotation Total to reflect any price increases from Manufacturer. This Proposal is based upon Dealer's current and expected inventory, which is subject to change. Dealer not obligated to retain any specific vehicles in stock, nor maintain any specific inventory level. Dealer shall not be obligated to fulfill Proposal in event quoted vehicle(s) not in stock or available within requested delivery schedule at time Proposal accepted. Dealer shall not be liable for any delay in providing or inability to provide Quoted Vehicle(s), where such inability or delay is due, in whole or in part, to any cause beyond the reasonable control of Dealer or is without the gross negligence or intended misconduct of Dealer. Above listed Trade Value based upon current appraisal of Trade Vehicle(s). Dealer may adjust Trade Value of Trade Vehicle(s) to reflect changes in condition and/or mileage of Trade Vehicle(s) between date of current appraisal and acceptance of this Proposal by Customer.



Hino Model 268A



CALL FOR PRICING

2018 Hino 268A
Hino J08E-WU
230HP / 520TQ
Allison 2200 RDS 6 speed Auto
Stock # 830348

LOCATION:

Austin TX

\$ 913,000

General

Unit Type New Medium Duty
Make Hino
Model 268A
Year 2018
Body Type Water Tank
Body Size 2000
Body MFG Niece
GVWR 25950
Stock Number 830348

Day Cab

Type Conventional
Interior Color Black

Exterior

Exterior Color WHITE

Engine

Engine MFG Hino
Engine Model J08E-WU
Horse Power 230hp
Torque 520 lb-ft
Engine Brake AIR
Air Cleaner MFG Donaldson

Chassis

Type 4x2
Wheel Base 152 inches

Tires and Wheels

Front Wheel Steel
Front Tire Size 22.5 inches
Rear Wheel Steel
Rear Tire Size 22.5 inches

Axle

Front Axle Suspension TaperLeaf
Front Axle Suspension Weight
12,000 lbs
Front Axle Weight 10,000 lbs
Rear Axle Ratio 5.57
Rear Axle Suspension Semi-elliptic
Rear Axle Weight 19,000 lbs

Transmission

Manufacturer Allison
Model 2200 RDS
Speed 6 speed Auto

Fuel Tanks

Tank #1 Type Aluminum
Tank #1 Capacity 90 gallons

water truck (1x)



Dallas TX LMD
 4000 Irving Boulevard
 Dallas, TX 75247
 214-631-2050

Customer Proposal Letter

Caldwell County
 110 S Main Street
 Lockhart, TX 78644
 (512) 359-4685

Water Truck

Danielle Blake, thank you for the opportunity to earn your business. We look forward to working with you on your business needs. Please accept the following proposal.

VEHICLE

Make Ford Model F-750 Year 2018 Stock Number 935025
 Additional Vehicle and Accessories Description _____ To be delivered on or about _____

Quantity	1	Total
Truck Price per Unit	\$70,450.00	\$70,450.00
F.E.T. (Factory & Dealer Paid)	\$0.00	\$0.00
Net Sales Price	\$70,450.00	\$70,450.00
Optional Extended Warranty(ies)		
State Sales Tax		
Documentary Fee		
Administration Fee		
Vehicle Inventory Tax		
Additional Taxes		
Tire Recycling Program		
Battery Disposal Fee		
Out of State Vehicle Fee		
Rebate(s)		
Total Sales Price (Including Rebate(s))	\$70,450.00	\$70,450.00
Trade Allowance (see DISCLAIMER Below)		\$0.00

Sales Representative	_____	James Galbreath
Purchaser	signature _____	printed name _____
	signature _____	printed name _____
Accepted by Sales Manager or General Manager	title _____	date _____
	signature _____	printed name _____

Quote good until 5/18/2019 **Note: The above Customer Proposal is a quotation only. Sale terms subject to approval of Sales Manager of Dealer.**

DISCLAIMER: Any order based on this Proposal subject to Customer executing Dealer's standard form Retail Purchase Order incorporating above terms. Any documentary fees, state tax, title, registration and license fees subject to adjustment and change. Actual F.E.T. to be paid by Dealer, subject to adjustment. Any F.E.T. variance will be responsibility of Dealer. Manufacturer has reserved the right to change the price to Dealer of any vehicle not currently in Dealer's stock, without notice to Dealer. If Quoted Vehicle(s) not currently in Dealer's stock, Dealer reserves right to change Quotation Total to reflect any price increases from Manufacturer. This Proposal is based upon Dealer's current and expected inventory, which is subject to change. Dealer not obligated to retain any specific vehicles in stock, nor maintain any specific inventory level. Dealer shall not be obligated to fulfill Proposal in event quoted vehicle(s) not in stock or available within requested delivery schedule at time Proposal accepted. Dealer shall not be liable for any delay in providing or inability to provide Quoted Vehicle(s), where such inability or delay is due, in whole or in part, to any cause beyond the reasonable control of Dealer or is without the gross negligence or intended misconduct of Dealer. Above listed Trade Value based upon current appraisal of Trade Vehicle(s). Dealer may adjust Trade Value of Trade Vehicle(s) to reflect changes in condition and/or mileage of Trade Vehicle(s) between date of current appraisal and acceptance of this Proposal by Customer.



Rush Medium Duty Truck Center, Dallas
4000 Irving Blvd., Dallas, Texas, 752475816
Office: 214-631-2050

Customer Proposal

Prepared by:

Ryan Galbreath
Office: 214-678-5966
Email: galbreathr@rushenterprises.com

Date: 01/05/2019

**Vehicle: 2018 F-750 Gas Base
Regular Cab**





**Rush Medium Duty Truck Center,
Dallas**
4000 Irving Blvd., Dallas, Texas, 752475816
Office: 214-631-2050

2018 F-750 Gas, Regular Cab
Regular Cab Base(F7A)
Price Level: 840

Table of Contents

Description	Page
Cover Page	1
Table of Contents	2
Selected Equip & Specs	3
Warranty - Standard	9
Selected Options	10
Pricing - Single Vehicle	14



Selected Equipment & Specs

Dimensions

Exterior length: 246.0" * Cab to axle: 84.0" * Exterior width: 96.7" * Exterior height: 92.9" * Wheelbase: 158.0" * Front track: 83.8" * Rear track: 72.6" * Rear tire outside width: 96.0" * Front legroom: 41.4" * Front headroom: 40.7" * Front hiproom: 67.6" * Front shoulder room: 68.0"

Powertrain

320hp 6.8L SOHC 30 valve V-10 engine with SMPI * Recommended fuel : regular unleaded * federal * TorqShift-G 6 speed automatic transmission with overdrive * Rear-wheel drive * Fuel Economy Cty: N/A * Fuel Economy Highway: N/A * 50.0 gal. rectangular Left front fuel tank * Transmission PTO provision * Standard rear differential * Right mounted horizontal muffler * Right mounted horizontal tailpipe

Suspension/Handling

Front non-independent leaf spring suspension * Rear rigid axle leaf spring suspension * Hydraulic power-assist recirculating ball Steering * Front and rear 22.5 x 8.25 wheels * 11.0R22.5 AS front and rear tires * Dual rear wheels * Rubber auxiliary rear springs

Body Exterior

2 doors * Driver and passenger heated, manual folding door mirrors * Black door mirrors * Black bumpers * Side steps * Clearcoat paint * Straight front bumper ends * Hood mounted grille * Front and rear 22.5 x 8.25 white steel wheels with 10 wheel studs * 2 front tow hook(s)

Convenience

Manual air conditioning * Cruise control with steering wheel controls * Manual front windows * Manual door locks * Manual tilt steering wheel * Front cupholders * Passenger visor mirror * Back-up alarm * Dual electric horn * Automatic gearshift steering column lever

Seats and Trim

Seating capacity of 2 * Fixed driver seat * Fixed passenger seat * Driver and passenger armrests * Bucket driver seat, Bucket passenger seat * Folding seat back * Low back seats * Driver seat air suspension * 4 way seat direction * Manual fore/aft seats * Fixed passenger seat headrest

Entertainment Features

AM/FM stereo radio * Auxiliary audio input * 2 speakers * Fixed antenna

Lighting, Visibility and Instrumentation

Halogen aero-composite headlights * Variable intermittent front windshield wipers * Light tinted windows * Front reading lights * Tachometer * Voltmeter * Oil pressure gauge * Trip computer * Trip odometer * RNDM

Safety and Security

4-wheel ABS brakes * Hydraulic disc brakes * Manual door locks

Dimensions

General Weights

Curb	9,346 lbs.	Front GAWR	12000 lbs.
Rear GAWR	21000 lbs.	GVWR	25999 lbs.
GCWR	37000 lbs.		

Front Weights

Front curb weight	5,727 lbs.	Front axle capacity	12,000 lbs.
Front spring rating	12,000 lbs.	Front tire/wheel capacity	12,350 lbs.

Rear Weights

Rear curb weight	3,619 lbs.	Rear axle capacity	21,000 lbs.
Rear spring rating	23,000 lbs.	Rear tire/wheel capacity	23,360 lbs.

Prices and content availability as shown are subject to change and should be treated as estimates only. Actual base vehicle, package and option pricing may vary from this estimate because of special local pricing, availability or pricing adjustments not reflected in the dealer's computer system. See salesperson for the most current information.



Selected Equipment & Specs (cont'd)

Fuel Tank type

Left front Fuel tank capacity 50.01 gal.

Front Frame

Height loaded 35 " Height unloaded 37 "

Rear Frame

Height loaded 37 " Height unloaded 38 "

Front And Rear GAWR Total Will Exceed Overall GVWR

Powertrain

Engine Type

Block material	Iron	Cylinders	V-10
Head material	Aluminum	Ignition	Spark
Injection	Sequential MPI	Liters	6.8L
Orientation	Longitudinal	Recommended fuel	Regular unleaded
Valves per cylinder	3	Valvetrain	SOHC

Engine Spec

Bore	3.55"	Compression ratio	9.2:1
Displacement	415 cu.in.	Stroke	4.16"

Engine Power

Output	320 HP @ 3,900 RPM	Torque	460 ft.-lb @ 3,000 RPM
--------	--------------------	--------	------------------------

Alternator

Amps 175

Battery

Cold cranking amps	1,800	Location	Forward right
Step	Yes	Type	Dual

Transmission

Electronic control	Yes	Lock-up	Yes
Overdrive	Yes	Speed	6
Type	Automatic		

Transmission Gear Ratios

1st	3.974	2nd	2.318
3rd	1.516	4th	1.149
5th	0.858	6th	0.674
Reverse Gear ratios	3.128		

Transmission Torque Converter

Stall ratio 2.00

Transmission Extras

Driver selectable mode	Yes	Oil cooler	Regular duty
PTO provision	Yes		

Drive Type

Type Rear-wheel

Drive Axle

Ratio 6.5

Prices and content availability as shown are subject to change and should be treated as estimates only. Actual base vehicle, package and option pricing may vary from this estimate because of special local pricing, availability or pricing adjustments not reflected in the dealer's computer system. See salesperson for the most current information.



Selected Equipment & Specs (cont'd)

Exhaust			
Material	Non stainless steel	System type	Single
Emissions			
CARB	Federal		
Driveability			
Brakes			
ABS Type	4-wheel Hydraulic disc	ABS channels	4
		Vented discs	Front and rear
Suspension Control			
Ride	Regular		
Front Suspension			
Independence	Non-independent	Type	Leaf
Front Spring			
Type	Tapered leaf	Grade	Regular
Front Shocks			
Type	Regular		
Rear Suspension			
Independence	Rigid axle	Type	Leaf
Rear Spring			
Type	Multi-leaf	Grade	Regular
Auxiliary	Rubber		
Steering			
Activation	Hydraulic power-assist	Type	Re-circulating ball
Steering Specs			
# of wheels	2		
Exterior			
Front Wheels			
Diameter	22.5"	Width	8.25"
Rear Wheels			
Diameter	22.5"	Width	8.25"
Dual	Yes		
Front Tires			
Aspect	82	Diameter	22.5"
Sidewalls	BSW	Tread	AS
Width	11.0"	LT load rating	G
RPM	496		
Rear Tires			
Aspect	82	Diameter	22.5"
Sidewalls	BSW	Tread	AS
Width	11.0"	LT load rating	G
RPM	496		

Prices and content availability as shown are subject to change and should be treated as estimates only. Actual base vehicle, package and option pricing may vary from this estimate because of special local pricing, availability or pricing adjustments not reflected in the dealer's computer system. See salesperson for the most current information.



Selected Equipment & Specs (cont'd)

Wheels

Front track	83.8"	Rear track	72.6"
Turning radius (to curb)	22'	Turning radius (to bumper)	23'
Wheelbase	158.0"	Rear tire outside width	96.0"

Body Features

Front splash guards	Yes	Body material	Composite/galvanized steel
Side steps	Yes	Front tow hook(s)	2

Body Doors

Door count	2
------------	---

Exterior Dimensions

Length	246.0"	Body width	96.7"
Body height	92.9"	Cab to axle	84.0"
Axle to end of frame	49.0"	Frame section modulus	15.1cu.in.
Frame yield strength (psi)	80000.0	Frame rail depth	10.3"
Frame rail width	3.1"	Frame rail thickness	0.4"
Max RBM (in.-lbs.)	1,275,200.0	Frame rail section	9.5"
Front bumper to Front axle	39.0"	Nominal RBM (in.-lbs.)	1,211,200.0

Seating

Passenger Capacity

Capacity	2
----------	---

Driver Seat

Type	Bucket	Back	Folding
Back type	Low	Suspension	Air
Way direction control	4	Fore/aft	Manual

Passenger Seat

Type	Bucket	Back	Folding
Back type	Low	Way direction control	4
Fore/aft	Manual		

Passenger Headrest

Type	Fixed
------	-------

Front Armrest

Driver	Yes	Passenger	Yes
--------	-----	-----------	-----

Front Seat Trim

Material	Vinyl	Back material	Carpet
----------	-------	---------------	--------

Convenience

AC And Heat Type

Air conditioning	Manual
------------------	--------

Audio System

Auxiliary audio input	Yes	Radio	AM/FM stereo
Radio grade	Regular	Seek-scan	Yes

Audio Speakers

Speaker type	Regular	Speakers	2
--------------	---------	----------	---

Prices and content availability as shown are subject to change and should be treated as estimates only. Actual base vehicle, package and option pricing may vary from this estimate because of special local pricing, availability or pricing adjustments not reflected in the dealer's computer system. See salesperson for the most current information.



Selected Equipment & Specs (cont'd)

Audio Antenna

Type Fixed

Cruise Control

Cruise control With steering wheel controls

Convenience Features

12V DC power outlet 2
 Horn Dual electric

Back-up alarm Yes

Door Lock Activation

Type Manual

Instrumentation Type

Display Analog

Instrumentation Gauges

Tachometer Yes
 Engine temperature Yes
 Transmission fluid temp Yes

Oil pressure Yes
 Voltmeter Yes
 Engine hour meter Yes

Instrumentation Warnings

Battery Yes
 Key Yes
 Brake fluid Yes

Lights on Yes
 Service interval Yes
 Transmission fluid temp Yes

Instrumentation Displays

Clock In-radio display

Instrumentation Feature

Trip computer Yes
 Shift indicator RNDM

Trip odometer Yes

Steering Wheel Type

Material Urethane

Tilting Manual

Front Side Windows

Window 1st row activation Manual

Window Features

Tinted Light

Front Windshield

Wiper Variable intermittent

Rear Windshield

Window Fixed

Automatic Gearshift

Location Steering column lever

Interior

Passenger Visor

Mirror Yes

Headliner

Coverage Full Material Cloth

Prices and content availability as shown are subject to change and should be treated as estimates only. Actual base vehicle, package and option pricing may vary from this estimate because of special local pricing, availability or pricing adjustments not reflected in the dealer's computer system. See salesperson for the most current information.



Selected Equipment & Specs (cont'd)

Floor Trim			
Coverage	Full	Covering	Vinyl/rubber
Trim Feature			
Gear shift knob	Urethane		
Lighting			
Dome light type	Delay	Front reading	Yes
Variable IP lighting	Yes		
Floor Console Storage			
Type	Partial		
Storage			
Front Beverage holder(s)	Yes	Glove box	Yes
Instrument panel	Bin	Dashboard	Yes
Legroom			
Front	41.4"		
Headroom			
Front	40.7"		
Hip Room			
Front	67.6"		
Shoulder Room			
Front	68.0"		

Prices and content availability as shown are subject to change and should be treated as estimates only. Actual base vehicle, package and option pricing may vary from this estimate because of special local pricing, availability or pricing adjustments not reflected in the dealer's computer system. See salesperson for the most current information.



Warranty - Standard Equipment & Specs

Warranty

Basic

Distance	Unlimited miles	Months	24 months
----------	-----------------	--------	-----------

Powertrain

Distance	100,000 miles	Months	60 months
----------	---------------	--------	-----------

Corrosion Perforation

Distance	Unlimited miles	Months	36 months
----------	-----------------	--------	-----------

Roadside Assistance

Distance	Unlimited miles	Months	24 months
----------	-----------------	--------	-----------

frame rail

Distance	Unlimited miles	Months	60 months
----------	-----------------	--------	-----------

Prices and content availability as shown are subject to change and should be treated as estimates only. Actual base vehicle, package and option pricing may vary from this estimate because of special local pricing, availability or pricing adjustments not reflected in the dealer's computer system. See salesperson for the most current information.



Selected Options

Code	Description
Base Vehicle	
F7A	Base Vehicle Price (F7A)
Engines	
99Y	6.8L 3V SEFI V10 Gasoline - 320 HP @ 3900 RPM Torque: 460 ft.lbs. @ 3000 rpm.
425	50-State Emissions
Transmissions	
44P	Ford TorqShift HD 6-Speed Automatic - Double Overdrive, less PTO Provision, less Park Pawl
41B	Transmission Power Take-Off Provision
Front Wheels & Tires	
643	Wheels, Front 22.5x8.25 White Powder Coated Steel, 10-Hole <i>(285.75MM BC) hub piloted, flanged nut, metric mount, 8.25 DC rims; with steel hubs.</i>
TCG	Tires, Front Two 11R22.5G Goodyear Endurance RSA (496 rev/mile)
Rear Wheels & Tires	
663	Wheels, Rear 22.5x8.25 White Powder Coated Steel, 10-Hole <i>(285.75MM BC) hub piloted, flanged nut, metric mount, 8.25 DC rims; with steel hubs.</i>
RCA	Tires, Rear Four 11R22.5G Goodyear G182 RSD (496 rev/mile)
Brakes	
67J	Hydraulic Brake System - Bosch HydroMax <i>Full power with automatic adjustment, 4-channel ABS antilock brake system. Includes 12" x 3" (Bosch) DSSA type rear axle mounted parking brake, Orscheln lever control, right of driver.</i>
Front Axle and Suspension	
43P	12,000 lb. Cap. Non-Driving - Dana E-1202I - I-Beam Type
61D	Taper-Leaf Springs, Parabolic - 12,000 lb. Cap <i>2-leaf, 62" x 3.15". Also includes, standard duty, dual, double acting shock absorbers.</i>
60A	Lube, Front Axle, EmGard 50W, Synthetic Oil

Prices and content availability as shown are subject to change and should be treated as estimates only. Actual base vehicle, package and option pricing may vary from this estimate because of special local pricing, availability or pricing adjustments not reflected in the dealer's computer system. See salesperson for the most current information.



Selected Options (cont'd)

Code	Description
Rear Axle and Suspension	
475	21,000 lb. Single Reduction - Open - Dana / Spicer 21060S <i>NOTE: When specifying an axle ratio, check performance guidelines for startability and gradeability.</i>
68R	Multi-Leaf Springs - 23,000 lb. Cap 11-leaf. Includes 2,000 lb auxiliary springs for load stabilization.
607	Lube, Rear Axle, EmGard 75W-90, Synthetic Oil
X6D	6.50 Axle Ratio
Wheelbase	
158WB	158" Wheelbase/84" CA/49" AF/246" OAL
Frame	
535	Single Channel - Straight 'C' 15.14 SM, 80,000 PSI 1,211,200 RBM. High strength low alloy steel. 10.250" x 3.092" x 0.375" (260.4mm x 78.5mm x 9.5mm).
18D	Special Rating GVWR - Limited to 25,999 lb. GVWR
Exhaust	
91H	Single, Horizontal Muffler - Frame Mounted Right Side Back of Cab w/Catalytic Converter <i>Downward facing, outlet lip.</i>
Fuel Tanks	
65A	Fuel Tank - LH 50 Gallon - Steel
12	12 Gal. Single Tank Fuel Fill. Mandatory Charge Applied, Based On Tank Selection
Electrical / Alternator / Battery	
17A	175 Amp Mitsubishi Alternator <i>Extra heavy duty 12 Volt.</i>
55M	Jump Start Stud - Remote Mounted
63B	Battery - Two 900 CCA, 1800 Total, Includes Steel Battery Box <i>12Volt, Motorcraft.</i>
59E	Body Builder Wiring - At End of Frame, Separate - (ILO Standard - Back of Cab Combined) <i>Includes sealed connectors for 2 ground circuits, with separate left/stop, separate right/stop, stop lamps, back up lamps. Also includes 2 additional pass through wires to cab.</i>
17M	Back-Up Alarm - Electric, 102 dBA
16V	Voltmeter

Prices and content availability as shown are subject to change and should be treated as estimates only. Actual base vehicle, package and option pricing may vary from this estimate because of special local pricing, availability or pricing adjustments not reflected in the dealer's computer system. See salesperson for the most current information.



Selected Options (cont'd)

Code	Description
<i>Available in message center.</i>	
Seats	
88R	30/0/30 Air Ride Driver (Integral Air Pump) & Fixed Passenger w/Console - Vinyl
Cab Interior	
600A	<p>Preferred Equipment Package 600A</p> <p><i>Includes:</i></p> <ul style="list-style-type: none"> - Bumper, Front - Black, Full Width - Wheel Seals, Front - Oil lubricated, SKF ScotSeal PlusXL Seals - Wheel Seals, Rear - Oil lubricated, SKF ScotSeal PlusXL Seals - Hydraulic Brake System - Bosch HydroMax Full power with automatic adjustment, 4-channel ABS antilock brake system. Includes 12" x 3" (Bosch) DSSA type rear axle mounted parking brake, Orschein lever control, right of driver. - 175 Amp Mitsubishi Alternator - Extra heavy duty 12 Volt. - Painted Grille - Plastic - Lights - Roof Marker/Clearance - Amber Lenses, 5 Lights - Tow Hooks, Front (2) - Frame-Mounted, Painted Black - Floor Covering - Black Vinyl - Intelligent Oil Life Monitor - Steering Column - Tilt - Steering Wheel - Black PVC w/Integral Cruise Control Switches
588	<p>Radio: AM/FM Stereo w/Aux Audio Input Jack & Clock</p> <p><i>With two speakers.</i></p>
Cab Exterior	
54M	<p>Mirrors, Dual - Heated Rectangular, XL2020 - 96" Width</p> <p><i>Integral spot mirror, sail type, manual fold, solid black finish.</i></p>
Ship-Thru	
21A	<p>Pre-Delivery Inspection</p> <p>Selection requires that you also choose either (314) or (31F) or (31V) to have the inspection performed.</p>
314	<p>Ship-Thru - Manning</p> <p>MAY be selected w/o adding (21A). For MODIFICATIONS ONLY, Dealer must make arrangements directly with Manning (please use CVT Resources for add. Info).</p>
Miscellaneous	
PAINT	Paint Type - Environmentally Friendly, "3 - Wet System"
Interior Colors	
E_01	Gray
Primary Colors	
YZ_01	Oxford White

Prices and content availability as shown are subject to change and should be treated as estimates only. Actual base vehicle, package and option pricing may vary from this estimate because of special local pricing, availability or pricing adjustments not reflected in the dealer's computer system. See salesperson for the most current information.



Selected Options (cont'd)

Code	Description
Upfit Options	
Ledwell2KGal	Ledwell 2K Gallon Water Tank

Prices and content availability as shown are subject to change and should be treated as estimates only. Actual base vehicle, package and option pricing may vary from this estimate because of special local pricing, availability or pricing adjustments not reflected in the dealer's computer system. See salesperson for the most current information.

27. Discussion/Action to approve Lease agreement between Caldwell County and the Health and Human Services Commission **Cost: None; Speaker: Judge Haden; Backup: 10**

Caldwell County Agenda Item Request Form

To: All Elected Officials and Department Heads – Hand deliver or scan & email to hoppy.haden@co.caldwell.tx.us and ezzy.chan@co.caldwell.tx.us . Deadline is 5:00 pm Tuesday before the Regular meetings, however, please submit this completed form ASAP. “Anything missing will cause the Agenda Item to be held over to the next Regular meeting,” according to our Rules & Procedures.

AGENDA DATE: _____

Type of Agenda Item

- Consent Discussion/Action Executive Session Workshop
 Public Hearing

What will be discussed? What is the proposed motion?

1. Costs:

Actual Cost or **Estimated Cost** \$ _____

Is this cost included in the County Budget? _____

Is a Budget Amendment being proposed? _____

2. Agenda Speakers:

Name	Representing	Title
------	--------------	-------

(1) _____

(2) _____

(3) _____

3. Backup Materials: None To Be Distributed _____ total # of backup pages
(including this page)

4. _____
Signature of Court Member

_____ **Date**



STATE LEASE AGREEMENT

1. PARTIES

This Lease Agreement (the “Lease”) is made by and between Caldwell County, Texas (“Lessor”), and the State of Texas, acting by and through the Health and Human Services Commission (“Lessee”), each a “Party” and collectively the “Parties,” pursuant to Lessee’s delegated authority from the Texas Facilities Commission (“TFC”) and in accordance with the provisions of *Texas Government Code* § 2167.051(2)(B).

2. LEASE REPRESENTATIVES

The following individuals will act as the designated Representative authorized to administer activities under this Lease on behalf of their respective Party. All non-legal notices given under this Lease by either Party shall be deemed delivered when received via e-mail, or deposited in the United States mail, postage paid, certified, return receipt requested, or with a common carrier, overnight, signature required, to the appropriate address below:

Lessor

Hoppy Haden
110 South Main Street, Suite 201
Lockhart, Texas 78644
(512) 398-1809
hoppy.haden@co.caldwell.tx.us

Lessee

Naomi Martinez, CTCM
4616-1 West Howard Lane, Suite 120
Austin, Texas 78728
(512) 832-7729
naomi.martinez@hhsc.state.tx.us

Either Party may change its designated Representative by written notice to the other Party.

3. PURPOSE AND PROPERTY LEASED

This Lease is entered into for the purpose of leasing real property owned by the Lessor to Lessee for use by one or more of its departments.

The real property to be leased shall be 4,484 total square feet, not including shared or common area space. This real property is more commonly described as the property located at 1403 Blackjack, Ste G & F, Lockhart, Texas 78644 (the “Premises”).

Lessor promises, in return for the consideration described herein to be paid by the Lessee and the covenants set out herein to be kept by Lessee, to hereby lease, unto the Lessee, the Premises described herein.

Lessee promises, in return for the consideration described herein to pay the Lessor from current revenues available to the Lessee.

4. TERMS OF LEASE

This Lease shall be for the initial period of 42 months commencing on March 1, 2019 (the “**Commencement Date**”), and ending on August 31, 2022 (the “**Termination Date**”), unless renewed, extended, or terminated pursuant to the terms and conditions of this Lease.

5. MONTHLY RENTAL

The Lessee agrees to pay Lessor a base monthly rent of **\$2,875.50** during the initial term of this Lease in accordance with Attachment A, Rent Schedule. The monthly rentals provided for herein shall be due and payable by Lessee in advance on the first day of the month for which said rentals are due.

This Lease is made and entered into contingent upon the continuation of the availability of money appropriated by the Texas Legislature to pay for this Lease. In the event the Texas Legislature or the Executive Branch of the State of Texas cease to fund this Lease, or the Lessee ceases to exist as a result of the Texas Legislative sunset review process, then the Lessee upon written notice to the Lessor, may terminate this Lease on the date set forth within the Lessee’s written notice or reaffirm this Lease for a successor-in-interest agency.

6. RENEWAL OPTION

By mutual agreement between Lessee and Lessor, this Lease may be renewed for any period or periods of time no greater than a cumulative total of nine and half (9.5) years, which nine and half-year period includes the initial lease term. Lessee shall give Lessor written notice of intention to either renew or not renew this Lease at least sixty (60) days prior to expiration of this Lease.

7. GENERAL LEASE COVENANTS

7.1 Lessee’s Covenants. This Lease is made upon the following additional expressed conditions and limitations, each of which Lessee covenants will be observed and performed throughout the initial term of this Lease and any extension thereof, and violation of any covenant thereof followed by written notice so declaring given by the Lessor’s designated Representative, if not cured within thirty (30) calendar days of such notice shall give Lessor the option to terminate this Lease:

- (a) The Premises hereby leased shall be used and occupied by the Lessee and one or more of its departments to facilitate the delivery of social services to residents of Texas and Caldwell County or other uses as deemed necessary by Lessee.
- (b) Lessee shall make no alterations, additions or improvements in, to or about the Premises without prior written consent of the Lessor.
- (c) Lessee will conform to such reasonable regulations which may be established from time to time by Lessor, for the general convenience of all of the tenants, except when such regulations conflict with federal and state laws or regulations, or agency procedures.
- (d) Lessee shall maintain in tenant able condition the Premises and, at the expiration or other termination of this Lease, shall surrender said Premises and fixtures in as good condition as reasonable use will permit. All injury to the building or fixtures caused by moving the property of the Lessee or occupying department(s) in or out of said building, and all breakage or any other injury done by the Lessee, or its agents, employees or invitees, when authorized by Lessee, shall be repaired by the Lessor at the expense of the Lessee.
- (e) Lessee, upon receiving forty-eight (48) hours written notice, will permit Lessor’s designated Representative, to enter upon and examine the Premises for the purposes of inspection and any repairs which Lessor deems necessary for the protection of the building and leased premises. In the event of emergency or disaster, Lessor shall not have to give notice.

7.2 Lessor's Covenants. This Lease is made upon the following additional expressed conditions and limitations, each of which Lessor covenants will be observed and performed throughout the initial term of this Lease and any extension thereof, and violation of any covenant thereof followed by written notice so declaring given by the Lessee's designated Representative, if not cured within thirty (30) calendar days of such notice shall give Lessee the option to terminate this Lease:

- (a) Shall allow Lessee to peaceably hold and enjoy the Premises.
- (b) Lessor shall make available for Lessee and occupying department(s) the necessary services for the operation and maintenance of the building, including but not limited to heating, air-conditioning, mechanical work and general upkeep of the complex.
- (c) In the event the Premises hereunder or any part thereof shall at any time during the term hereof be damaged by fire or other such casualty, so as to be unfit for the use and occupancy, the rent provided herein, or a just and proportionate part thereof, according to the nature and extent of the damage sustained, shall be abated until the said Premises shall have been duly repaired and restored by the Lessor, or, in case the said building be substantially destroyed then at the election of either the Lessor or Lessee, this Lease may be terminated and the Parties shall be released from all obligations under this Lease.
- (d) During the term of this Lease, Lessor will not rent, lease, or otherwise furnish space in this or and adjacent building under its control to any enterprise which in the usual exercise of its business, could be expected to create noise or odors injurious or disruptive to the Lessee's or occupying department(s) normal governmental activity. Lessor shall not lease space that would locate or collocate any regulated parties which have an interest in the Lessee or whose occupation of these premises would cause the Lessee to be in violation of a state statute.
- (e) Lessor will provide furniture to meet the needs of Lessee or occupying department(s). Said property shall include but not limited to multifunction work stations/ desk, task chairs, tables, filing cabinets.
- (f) Lessee or occupying department(s) may bring on the Premises any additional furniture, fixtures, and equipment reasonable necessary for the efficient exercise of Lessee's governmental responsibilities and the Parties agree that all such property shall remain the property of the Lessee or occupying department(s) (e.g. including but not limited to personal computers, printers, facsimile, and postage meter). The Lessor shall furnish the waiting and break areas and the Parties agree that all furniture and appliances within these areas are the property of the Lessor, unless clearly marked as state property.
- (g) The Lessor shall provide a temperature controlled secured room to house the Lessee's network equipment and permit Lessee to establish network connectivity via cabling throughout the Premises to accommodate the Lessee's or occupying department(s) needs.
- (h) Lessor shall maintain Premises and buildings in tenantable condition and promptly cure all defects and/or make required repairs with seven (7) calendar days of notice. Conditions presenting life, safety or security breaches must be cured no later than twenty-four (24) hours of such notice. Lessor's failure to reasonably comply may result in the Lessee completing needed repairs at the Lessor's expense. The commercially reasonable cost thereof shall be deducted by the Lessee from the following month's rent.
- (i) Lessor must maintain a policy of all-risk property insurance, issued by and bonded upon an insurance company licensed in the State of Texas, covering the Premises and leasehold improvements (exclusive of contents), in an amount equal to not less than 80% percent of the replacement cost thereof. Lessee shall have no interest in the policy or policy proceeds and Lessor shall not be obligated to insure any furnishings, equipment, trade fixtures, or other personal property that Lessee may place or cause to be placed upon the Premises.

- (j) Lessor must maintain a policy or policies of comprehensive general liability insurance insuring Lessor against loss of life, bodily injury and/or property damage with respect to Common Areas, operation of the Building, parking lots and other improvements associated with the land upon which the Premises are located, and any other losses caused by or related to the duties and obligations of Lessor under this Lease. Lessor shall designate Lessee as an additional insured on the policy.
- (k) Lessor acknowledges that, because Lessee is an agency of the State of Texas, liability for the tortious conduct of the agents and employees of Lessee (other than medical liability of medical staff physicians) or for injuries caused by conditions of tangible state property is provided for solely by the provisions of the "Texas Tort Claims Act," *Texas Civil Practice and Remedies Code* Chapters 1010 and 104, and that Workers' Compensation Insurance coverage for employees of Lessee is provided by Lessee as mandated by the provisions of *Texas Labor Code* Chapter 503. Lessor further acknowledges that, as an agency of the State of Texas, Lessee has only such authority as is granted to Lessee by state law or as may be reasonably implied from such law, and that Lessee shall have the right, at its option, to (a) obtain liability insurance protecting Lessee and its employees and property insurance protecting Lessee's buildings and the contents; or (b) self-insure against any risk that may be incurred by Lessee as a result of its operations under this Lease. Any obligation by Lessee under this Lease to obtain insurance is expressly made subject to the Lessee's authority under state law to obtain such insurance. No insurance carrier of either Party shall have a right of subrogation against the other Party to this Lease.

8. LEASE REQUIREMENTS

- 8.1 Condition of Premises. Lessor warrants that the Premises is not in violation of any city, state, or local ordinance or statute or any restrictions imposed against the Premises for the Lessee or occupying department(s) intended governmental purpose.
- 8.2 Adverse Building Conditions. Lessee reserves the right of inspection and may reject space based on adverse building conditions, including but not limited to general cleanliness, appearance of carpet or tile, grounds, finished interiors or exteriors, odors, pests, insects, or other problems relating to improper extermination, or any other condition that would create unsanitary, unattractive or unsafe conditions.
- 8.3 Minimum Square Footage. As a condition of occupancy, Lessor certifies that the Premises contains the minimum usable square footage specified in this Lease.
- 8.4 Payment of Utilities. The Lessee will be responsible to reimbursement Lessor for utilities based upon a prorated amount for the entire 3,834 square feet in Suite G. Lessee will be responsible to reimbursement Lessor for utilities based upon a prorated amount of thirty six (36) percent for the entire 650 square feet in Suite F. Lessor will be responsible for providing Lessee access to all utilities services, meters, and connections necessary for the proper and intended use of the space. These utilities include telecommunications facilities, cable and internet, continuous hot and cold water, wastewater, electricity and natural gas, if required for heating and or cooling.
- 8.5 Telephone System. Lessor will be responsible for providing and maintaining the telephone system for local/long distance phone services at the Premises. Lessee shall be responsible for providing and maintaining long distance service and equipment at its own expense.

- 8.6 Burglar Alarm System. Lessee will be responsible for providing and maintaining a burglar alarm system and locking system at the Premises.
- 8.7 Exterior Doors and Keys. All exterior doors shall be keyed with non-duplicating keys. Lessor shall furnish keys, individually numbered, as requested by Lessee. All exterior exit doors shall be solid core doors (where applicable) and equipped, unless otherwise required by code, with deadbolt locks with a minimum one-inch throw bolt. All door hardware and automatic door closers shall be of sufficiently sturdy construction to ensure security.
- 8.8 Janitorial Services and Supplies. Lessee will be responsible for janitorial services for the Premises.
- 8.9 Pest Control. Lessor shall provide quarterly interior and exterior pest control services, and any additional pest control services as needed.
- 8.10 Maintenance of Building. Lessor will be responsible for keeping the Premises and building(s) in good repair and condition during the continuance of the term of this Lease. During the continuance of the term of this Lease, said maintenance is to include, but not be limited to the following services: repair and patch wall, ceiling and floor surfaces; painting as needed; replacement of broken window glass; repair of window shades, blinds and/or drapes, fasteners, and sash cord or chains; roof and ceiling leaks; building exterior, interior; plumbing, heating, air conditioning and ventilating equipment and filters; fire protection equipment; miscellaneous valves; woodwork, locks, floor surfaces and coverings; lighting fixtures, and the replacement of all defective or burned out light bulbs, fluorescent tubes, ballasts and starters. If the Lessee, or its agents, cause damage to said property that goes beyond "normal wear and tear" the Lessee is responsible to repair or pay for those repairs.
- 8.11 Deferred Maintenance and Repairs. Lessor within one hundred and eighty (180) days of the effective date of this Lease will either repair, replace, update, or rehabilitate the following items:
- (a) Replace damaged VCT throughout the bathroom.
 - (b) Clean the carpet throughout facility.
 - (c) Repair all parking stops.
 - (d) Pave and/ or repair parking lot.
 - (e) Restripe 19 parking spaces and 2 accessible parking spaces in accordance with Texas Accessibility Standards ("TAS").
 - (f) Power wash sidewalks and front entrance of facility.
- 8.12 Non-Smoking Area. Lessor will designate the leased space occluded under this Lease as a "non-smoking area."
- 8.13 Parking. Lessor shall provide ample off-street parking for client and staff vehicles. Parking must be under the direct control of the Lessor and must be located within a reasonable distance of the entry to the Premises. Lessor shall also provide accessible parking spaces in accordance with TAS.
- 8.14 Exterior off Building Maintenance. Lessor shall maintain the exterior of the building and adjacent grounds in an appropriate manner. Lessor agrees to make diligent efforts to landscape with Texas flora. All grass, trees, shrubbery and other landscaping must be maintained on a regular basis. Water used by Lessor for landscaping and/or decorative purposes shall be paid for by Lessor.

9. GENERAL TERMS AND CONDITIONS

- 9.1 Conversion to Limited Month-to-Month Lease. Lessee may, upon written notice to the Lessor at least thirty (30) days prior to termination of this Lease or any extension, remain in possession of the Premises for a period specified in the notice, not to exceed one hundred eighty (180) days. The Lessee shall pay the Lessor for each month or part of a month, a pro-rata sum equal to the Monthly Rent in effect at the termination of this lease for the space occupied by the agency during this period.
- 9.2 Termination for Convenience. Lessor and Lessee expressly agree that either Party may, at any time within the initial or any renewal period, terminate this Lease without incurring any further liability after termination by providing, as appropriate, written notice not less than one hundred twenty (120) calendar days before the specified termination date.
- 9.3 Payment of Taxes. Lessor, when applicable, will be responsible to pay all taxes of whatever nature, levied and assessed and to be levied or assessed, on or against the Premises and improvements during the term of this Lease.
- 9.4 Signage. Any signs necessary to indicate the Lessee's or occupying department(s) name, location and governmental purpose shall be prepared and installed consistent with signage for other lessees in the property and in keeping with building décor. Lessor shall provide the Lessee with a copy of its standardized signage rules prior to execution of this Lease. Any special requirements of Lessee standardized signage rule, must be stating in writing and made a part of this Lease. Any cost of compliance with this section in excess of the amount that would be required for the Lessor's standard signage shall be borne by the Lessee.
- 9.5 Property of Lessee. On termination of this Lease, by lapse of time or otherwise, the Lessee and/or occupying department(s), may for one hundred eighty (180) calendar days thereafter, at its option and expense remove from said Premises any and all improvements, equipment, appliances or other property placed or owned by it thereon. The Parties by mutual agreement may either reduce or extend the time allowed for the Lessee and/or occupying department(s) to remove its property. Lessee shall deliver the Premises to Lessor in good order and condition, provided however, the reasonable use and ordinary wear and tear are expected.
- 9.6 Condemnation. If during the term of this Lease, said Premises, or any portion thereof, shall be condemned for any public purpose, Lessee hereto shall have the option of terminating and canceling this Lease upon thirty (30) days notice to the Lessor of its election to do so.
- 9.7 Commencement of Occupancy. Lessee is not obligated to pay rent and other sums under this Lease until the premises are available to Lessee for full occupancy and are suitable for use as office space for a state agency. If Lessor is unable to give Lessee full possession of the Premises on Commencement Date for any reason, Lessor shall give Lessee immediate written notice of the cause for the delay and the date the Premises will be ready for occupancy. If full possession is delayed, Lessee, in its sole discretion, may terminate this Lease at any time without liability to the State of Texas or Lessee, and seek other leased space.

If the Lessee so elects, the Lessee may continue to treat this Lease as if in full force and effect for a period of no more than one hundred twenty (120) calendar days after the Commencement Date of this Lease. During this time, or for as long as possession does not commence, the rent shall not be paid.

- 9.8 **Abandonment.** The Lessee or occupying department(s) will not, without notifying the Lessor, abandon the Premises, or allow the Premises to become vacant or deserted. In the event the Lessee's need for such space terminates, the Lessee will make every attempt to notify the Lessor one hundred twenty (120) calendar days before vacating the Premises, but will accrue no liability if such notice cannot be given.
- 9.9 **Assignment.** Lessee reserves the right to assign any agency of State government to occupy all or any part of the space described herein or to assign or sublet all or any part of the Premises to any private entities (persons or corporations) it deems to be in the best interest of the state of Texas.
- 9.10 **Default by Lessor.** In the event Lessor shall breach or be in default in the strict performance of any of the covenants or obligations imposed upon Lessor by this Lease, and shall remain in default for a period of thirty (30) calendar days after written notice of such default, Lessee shall have the right to terminate this Lease, and shall have the remedies now or hereafter provided by law for recovery of damages occasioned by such default. Lessee specifically shall be entitled to deduct amounts expended on repairs necessary to maintain the suitability and habitability of the Premises.
- 9.11 **Default By Lessee.** If Lessee fails to pay rentals or other charges hereunder or otherwise fails to perform its obligations hereunder and this failure is not cured within sixty (60) calendar days after written notice from Lessor to Lessee of such failure, then Lessee is in default, and Lessor may terminate this Lease and may enter and take possession of Premises, and will have the remedies now or hereafter provided by law for recovery of rent, repossession of premises, and damages occasioned by Lessee's default.
- 9.12 **Failure to Enforce.** The failure of the Lessee or Lessor to insist in any one or more instances on a strict performance of any of the covenants or conditions of this Lease shall not be construed as a waiver or relinquishment of such covenants or conditions in future instances, but the same shall continue and remain in full force and effect.
- 9.13 **Legal Notices.** Any legal notice required under this Lease shall be deemed delivered when deposited by the Lessee either in the United States mail, postage paid, certified, return receipt requested; or with a common carrier, overnight, signature required, to the appropriate address below:

Lessor

Caldwell County, Texas
 Attn: Hopy Haden, County Judge
 110 South Main Street, Suite 201
 Lockhart, Texas 78644

Lessee

Health and Human Services Commission
 Attn: Office of the Chief Counsel
 4900 N. Lamar Boulevard; MC 1100
 Austin, Texas 78751-6500

Legal notice given by Lessor shall be deemed effective when received by the Lessee. Either Party may change its address for legal notice by written notice to the other Party.

- 9.14 **State Auditor's Office.** Lessor understands that acceptance of funds under this Lease acts as acceptance of the authority of the State Auditor's Office, or any successor agency, to conduct an audit or investigation in connection with those funds. Lessor further agrees to cooperate fully with the State Auditor's Office or its successor in the conduct of the audit or investigation, including providing all records requested. Lessor will ensure that this clause concerning the authority to audit funds received indirectly by contractors or subcontractors through Lessor and the requirement to cooperate is included in any contract related to this Lease that the Lessor may award.

9.15 Texas Accessibility Standards. In signing this Lease, the Lessor certifies that the Premises to be occupied shall comply with all applicable federal, state and local laws, statutes, ordinances, codes, rules, and regulations, which include compliance with all applicable handicapped accessibility requirements. Acceptance of the space does not exonerate the Lessor from meeting all the requirements. No requirement may be waived by the Lessee.

Lessor specifically covenants and warrants that the Premises and leased space will at all times comply with the TAS requirements for persons with disabilities administered by the Texas Department of Licensing and Regulations.

9.16 Sovereign Immunity. Nothing in this Lease will be construed as a waiver of sovereign immunity by the state of Texas or Lessee. Notwithstanding the forgoing, if Lessor is a state agency or department, district, authority, county, municipality, or other political subdivision of the state, then nothing in this Lease should be construed to abrogate any rights or affirmative defenses available to Lessee and Lessor under doctrines of sovereign and official immunity.

9.17 Governing Law and Venue. This Lease and the rights and obligations of the Parties hereto will be governed by, and construed according to, the laws of the state of Texas, exclusive of conflicts of law provisions. Venue of any suit brought under this Lease will be in a court of competent jurisdiction in Travis County, Texas, unless otherwise elected by the Lessee. Lessor irrevocably waives any objection, including any objection to personal jurisdiction or the laying of venue or based on the grounds of forum non conveniens, which it may now or hereafter have to the bringing of any action or proceeding in such jurisdiction in respect of this Lease or any document related hereto.

9.18 Entire Lease and Amendments. This Lease and attachments hereto constitute the entire agreement between the Parties. All prior proposals, negotiations, notices, and representations not incorporated herein are void and have no legal effect. Any future amendment or modification to this Lease are not valid unless evidenced in writing and signed by the Lessor and Lessee.

10. SIGNATURES

This Lease is effective as of the Commencement Date written above.

LESSOR:
Caldwell County, Texas

LESSEE:
State of Texas, acting by and through the Health and Human Services Commission

By: _____
Honorable Hoppy Haden
Caldwell County Judge

By: _____
Cindy Coffey
Regional Director for Regional Administrative Services

Date: _____

Date: _____

Attachment A

RENT SCHEDULE

Agency / Occupying Department(s)	Usable Sq. Ft.	Annual Base Rate / SF	Annual Base Rent	Monthly Base Rent
HHSC / AES	3,834 sq. ft.	\$9.05	\$120,771.00	\$2,875.50

28. PUBLIC HEARING at 9:30 AM concerning the approval of a Preliminary Plat for Hartland Subdivision to include 20 lots on approximately 177.5 acres located on Borchert Loop. **Cost: None. Speaker: Commissioner Westmoreland /Kasi Miles. Backup: 8**

Caldwell County Agenda Item Request Form

To: All Elected Officials and Department Heads – Hand deliver or scan & email to hopy.haden@co.caldwell.tx.us and ezzy.chan@co.caldwell.tx.us . Deadline is 5:00 pm Tuesday before the Regular meetings, however, please submit this completed form ASAP. "Anything missing will cause the Agenda Item to be held over to the next Regular meeting," according to our Rules & Procedures.

AGENDA DATE: 5/13/19

Type of Agenda Item

- Consent Discussion/Action Executive Session Workshop
- Public Hearing

What will be discussed? What is the proposed motion?
Preliminary Plat for Hartland Ranch

1. Costs:

Actual Cost or Estimated Cost \$ 0

Is this cost included in the County Budget? n/a

Is a Budget Amendment being proposed? n/a

2. Agenda Speakers:

	<u>Name</u>	<u>Representing</u>	<u>Title</u>
(1)	Kasi Miles	Caldwell County	Director of Sanitation
(2)			
(3)			

3. Backup Materials: None To Be Distributed 8 total # of backup pages (including this page)

Approved by phone

Commissioner Westmoreland 5-7-19
Signature of Court Member Date



**Proposed subdivision of
land named:**

Hartland Ranch

**set for a future public
hearing for Preliminary
and Final Plat through
Caldwell County
Commissioners Court**

Caldwell CAD

Property Search Results > 31847 J & P LOCKHART BUILDERS LP for Tax Year: 2019
Year 2019

Property

Account

Property ID:	31847	Legal Description:	A137 HUNT, MEMUCAN, ACRES 177.5, 142.5 AC. IN HUNT A-137, 35 AC IN STEFFY A-274
Geographic ID:	0200137-100-000-00	Zoning:	
Type:	Real	Agent Code:	ID:225873
Property Use Code:			
Property Use Description:			

Location

Address:	BORCHERT LP LOCKHART, TX 78644	Mapsco:	03-398
Neighborhood:	RURAL SE RIVER RD-DICKERSON RD-BORCHERT LP AREA	Map ID:	03-398
Neighborhood CD:	4130		

Owner

Name:	J & P LOCKHART BUILDERS LP	Owner ID:	222604
Mailing Address:	C/O JAKOVICH JARED 2814 BORCHERT LOOP LOCKHART, TX 78644-4823	% Ownership:	100.0000000000%
		Exemptions:	

Values

(+) Improvement Homesite Value:	+	\$0	
(+) Improvement Non-Homesite Value:	+	\$0	
(+) Land Homesite Value:	+	\$0	
(+) Land Non-Homesite Value:	+	\$794,160	Ag / Timber Use Value
(+) Agricultural Market Valuation:	+	\$0	\$0
(+) Timber Market Valuation:	+	\$0	\$0

(=) Market Value:	=	\$794,160	
(-) Ag or Timber Use Value Reduction:	-	\$0	

(=) Appraised Value:	=	\$794,160	
(-) HS Cap:	-	\$0	

(=) Assessed Value:	=	\$794,160	

Taxing Jurisdiction

Owner: J & P LOCKHART BUILDERS LP
% Ownership: 100.0000000000%
Total Value: \$794,160

Entity	Description	Tax Rate	Appraised Value	Taxable Value	Estimated Tax
CAD	Caldwell Appraisal District	0.000000	\$794,160	\$794,160	\$0.00
CESD2	Caldwell County ESD #2	0.100000	\$794,160	\$794,160	\$794.16

FTM	Farm to Market Road	0.000100	\$794,160	\$794,160	\$0.79
GCA	Caldwell County	0.775200	\$794,160	\$794,160	\$6,156.32
SLH	Lockhart ISD	1.332360	\$794,160	\$794,160	\$10,581.07
WPC	Plum Creek Conservation District	0.023200	\$794,160	\$794,160	\$184.25
WUG	Plum Creek Underground Water	0.021400	\$794,160	\$794,160	\$169.95
	Total Tax Rate:	2.252260			
				Taxes w/Current Exemptions:	\$17,886.54
				Taxes w/o Exemptions:	\$17,886.55

Improvement / Building

No improvements exist for this property.

Land

#	Type	Description	Acres	Sqft	Eff Front	Eff Depth	Market Value	Prod. Value
1	NHS	NON HOMESITE	177.5000	7731900.00	0.00	0.00	\$794,160	\$0

Roll Value History

Year	Improvements	Land Market	Ag Valuation	Appraised	HS Cap	Assessed
2019	\$0	\$794,160	0	794,160	\$0	\$794,160
2018	\$0	\$651,020	44,020	44,020	\$0	\$44,020
2017	\$0	\$552,690	43,310	43,310	\$0	\$43,310
2016	\$0	\$462,050	42,960	42,960	\$0	\$42,960
2015	\$0	\$435,880	44,380	44,380	\$0	\$44,380
2014	\$0	\$403,620	41,890	41,890	\$0	\$41,890
2013	\$0	\$403,620	39,410	39,410	\$0	\$39,410
2012	\$0	\$403,620	39,580	39,580	\$0	\$39,580
2011	\$0	\$403,620	39,580	39,580	\$0	\$39,580
2010	\$0	\$373,650	39,760	39,760	\$0	\$39,760
2009	\$0	\$373,650	37,810	37,810	\$0	\$37,810
2008	\$0	\$373,720	36,210	36,210	\$0	\$36,210
2007	\$0	\$325,290	34,970	34,970	\$0	\$34,970
2006	\$0	\$325,290	40,650	40,650	\$0	\$40,650
2005	\$0	\$295,720	40,290	40,290	\$0	\$40,290

Deed History - (Last 3 Deed Transactions)

#	Deed Date	Type	Description	Grantor	Grantee	Volume	Page	Deed Number
1	12/19/2017	WD	WARRANTY DEED	GLENVOIR FARM	J & P LOCKHART BUILDERS LP			2018-000860
2		OT	OTHER - ALL BLANK FIELDS FROM CONVERSION	JANNEY KATIE THOMSON	GLENVOIR FARM	403	671	0

Tax Due

Property Tax Information as of 05/07/2019

Amount Due if Paid on: 

Year	Taxing Jurisdiction	Taxable Value	Base Tax	Base Taxes Paid	Base Tax Due	Discount / Penalty & Interest	Attorney Fees	Amount Due
2018	Farm to Market Road	\$44,020	\$0.04	\$0.04	\$0.00	\$0.00	\$0.00	\$0.00
2018	Caldwell County	\$44,020	\$341.24	\$341.24	\$0.00	\$0.00	\$0.00	\$0.00
2018	Lockhart ISD	\$44,020	\$586.51	\$586.51	\$0.00	\$0.00	\$0.00	\$0.00
2018	Plum Creek Underground Water	\$44,020	\$9.42	\$9.42	\$0.00	\$0.00	\$0.00	\$0.00

2018	Plum Creek Conservation District	\$44,020	\$10.21	\$10.21	\$0.00	\$0.00	\$0.00	\$0.00
2018	Caldwell County ESD #2	\$44,020	\$44.02	\$44.02	\$0.00	\$0.00	\$0.00	\$0.00
	2018 TOTAL:		\$991.44	\$991.44	\$0.00	\$0.00	\$0.00	\$0.00
	J & P LOCKHART BUILDERS LP TOTAL:		\$991.44	\$991.44	\$0.00	\$0.00	\$0.00	\$0.00
2017	Plum Creek Underground Water	\$43,310	\$9.27	\$9.27	\$0.00	\$0.00	\$0.00	\$0.00
2017	Farm to Market Road	\$43,310	\$0.04	\$0.04	\$0.00	\$0.00	\$0.00	\$0.00
2017	Caldwell County	\$43,310	\$335.74	\$335.74	\$0.00	\$0.00	\$0.00	\$0.00
2017	Lockhart ISD	\$43,310	\$577.04	\$577.04	\$0.00	\$0.00	\$0.00	\$0.00
2017	Plum Creek Conservation District	\$43,310	\$10.05	\$10.05	\$0.00	\$0.00	\$0.00	\$0.00
2017	Caldwell County ESD #2	\$43,310	\$43.22	\$43.22	\$0.00	\$0.00	\$0.00	\$0.00
	2017 TOTAL:		\$975.36	\$975.36	\$0.00	\$0.00	\$0.00	\$0.00
2016	Caldwell County ESD #2	\$42,960	\$42.96	\$42.96	\$0.00	\$0.00	\$0.00	\$0.00
2016	Farm to Market Road	\$42,960	\$0.04	\$0.04	\$0.00	\$0.00	\$0.00	\$0.00
2016	Caldwell County	\$42,960	\$333.02	\$333.02	\$0.00	\$0.00	\$0.00	\$0.00
2016	Lockhart ISD	\$42,960	\$572.38	\$572.38	\$0.00	\$0.00	\$0.00	\$0.00
2016	Plum Creek Conservation District	\$42,960	\$9.88	\$9.88	\$0.00	\$0.00	\$0.00	\$0.00
2016	Plum Creek Underground Water	\$42,960	\$9.24	\$9.24	\$0.00	\$0.00	\$0.00	\$0.00
	2016 TOTAL:		\$967.52	\$967.52	\$0.00	\$0.00	\$0.00	\$0.00
2015	Caldwell County ESD #2	\$44,380	\$44.38	\$44.38	\$0.00	\$0.00	\$0.00	\$0.00
2015	Farm to Market Road	\$44,380	\$0.04	\$0.04	\$0.00	\$0.00	\$0.00	\$0.00
2015	Caldwell County	\$44,380	\$318.38	\$318.38	\$0.00	\$0.00	\$0.00	\$0.00
2015	Lockhart ISD	\$44,380	\$590.47	\$590.47	\$0.00	\$0.00	\$0.00	\$0.00
2015	Plum Creek Conservation District	\$44,380	\$9.99	\$9.99	\$0.00	\$0.00	\$0.00	\$0.00
2015	Plum Creek Underground Water	\$44,380	\$9.54	\$9.54	\$0.00	\$0.00	\$0.00	\$0.00
	2015 TOTAL:		\$972.80	\$972.80	\$0.00	\$0.00	\$0.00	\$0.00
2014	Lockhart ISD	\$41,890	\$598.65	\$598.65	\$0.00	\$0.00	\$0.00	\$0.00
2014	Plum Creek Underground Water	\$41,890	\$9.22	\$9.22	\$0.00	\$0.00	\$0.00	\$0.00
2014	Plum Creek Conservation District	\$41,890	\$9.22	\$9.22	\$0.00	\$0.00	\$0.00	\$0.00
2014	Farm to Market Road	\$41,890	\$0.04	\$0.04	\$0.00	\$0.00	\$0.00	\$0.00
2014	Caldwell County	\$41,890	\$289.26	\$289.26	\$0.00	\$0.00	\$0.00	\$0.00
2014	Caldwell County ESD #2	\$41,890	\$41.89	\$41.89	\$0.00	\$0.00	\$0.00	\$0.00
	2014 TOTAL:		\$948.28	\$948.28	\$0.00	\$0.00	\$0.00	\$0.00
2013	Lockhart ISD	\$39,410	\$464.84	\$464.84	\$0.00	\$0.00	\$0.00	\$0.00
2013	Plum Creek Underground Water	\$39,410	\$8.67	\$8.67	\$0.00	\$0.00	\$0.00	\$0.00
2013	Plum Creek Conservation District	\$39,410	\$8.67	\$8.67	\$0.00	\$0.00	\$0.00	\$0.00
2013	Farm to Market Road	\$39,410	\$0.04	\$0.04	\$0.00	\$0.00	\$0.00	\$0.00
2013	Caldwell County	\$39,410	\$272.17	\$272.17	\$0.00	\$0.00	\$0.00	\$0.00
2013	Caldwell County ESD #2	\$39,410	\$39.41	\$39.41	\$0.00	\$0.00	\$0.00	\$0.00
	2013 TOTAL:		\$793.80	\$793.80	\$0.00	\$0.00	\$0.00	\$0.00
2012	Plum Creek Underground Water	\$39,580	\$8.31	\$8.31	\$0.00	\$0.00	\$0.00	\$0.00
2012	Lockhart ISD	\$39,580	\$469.73	\$469.73	\$0.00	\$0.00	\$0.00	\$0.00
2012	Plum Creek Conservation District	\$39,580	\$8.31	\$8.31	\$0.00	\$0.00	\$0.00	\$0.00
2012	Farm to Market Road	\$39,580	\$0.04	\$0.04	\$0.00	\$0.00	\$0.00	\$0.00
2012	Caldwell County	\$39,580	\$273.38	\$273.38	\$0.00	\$0.00	\$0.00	\$0.00
2012	Caldwell County ESD #2	\$39,580	\$39.18	\$39.18	\$0.00	\$0.00	\$0.00	\$0.00
	2012 TOTAL:		\$798.95	\$798.95	\$0.00	\$0.00	\$0.00	\$0.00
2011	Plum Creek Underground Water	\$39,580	\$7.92	\$7.92	\$0.00	\$0.00	\$0.00	\$0.00
2011	Lockhart ISD	\$39,580	\$470.29	\$470.29	\$0.00	\$0.00	\$0.00	\$0.00
2011	Plum Creek Conservation District	\$39,580	\$7.92	\$7.92	\$0.00	\$0.00	\$0.00	\$0.00
2011	Farm to Market Road	\$39,580	\$0.04	\$0.04	\$0.00	\$0.00	\$0.00	\$0.00
2011	Caldwell County	\$39,580	\$273.42	\$273.42	\$0.00	\$0.00	\$0.00	\$0.00
2011	Caldwell County ESD #2	\$39,580	\$38.71	\$38.71	\$0.00	\$0.00	\$0.00	\$0.00
	2011 TOTAL:		\$798.30	\$818.30	\$0.00	\$0.00	\$0.00	\$0.00
2010	Lockhart ISD	\$39,760	\$475.05	\$475.05	\$0.00	\$0.00	\$0.00	\$0.00

2010	Plum Creek Underground Water	\$39,760	\$7.75	\$7.75	\$0.00	\$0.00	\$0.00	\$0.00
2010	Plum Creek Conservation District	\$39,760	\$7.75	\$7.75	\$0.00	\$0.00	\$0.00	\$0.00
2010	Farm to Market Road	\$39,760	\$0.04	\$0.04	\$0.00	\$0.00	\$0.00	\$0.00
2010	Caldwell County	\$39,760	\$274.70	\$274.70	\$0.00	\$0.00	\$0.00	\$0.00
2010	Caldwell County ESD #2	\$39,760	\$39.76	\$39.76	\$0.00	\$0.00	\$0.00	\$0.00
	2010 TOTAL:		\$805.05	\$805.05	\$0.00	\$0.00	\$0.00	\$0.00
2009	Lockhart ISD	\$37,810	\$465.06	\$465.06	\$0.00	\$0.00	\$0.00	\$0.00
2009	Plum Creek Underground Water	\$37,810	\$6.99	\$6.99	\$0.00	\$0.00	\$0.00	\$0.00
2009	Plum Creek Conservation District	\$37,810	\$6.99	\$6.99	\$0.00	\$0.00	\$0.00	\$0.00
2009	Farm to Market Road	\$37,810	\$0.08	\$0.08	\$0.00	\$0.00	\$0.00	\$0.00
2009	Caldwell County	\$37,810	\$261.19	\$261.19	\$0.00	\$0.00	\$0.00	\$0.00
	2009 TOTAL:		\$740.31	\$740.31	\$0.00	\$0.00	\$0.00	\$0.00
2008	Lockhart ISD	\$36,210	\$442.66	\$442.66	\$0.00	\$0.00	\$0.00	\$0.00
2008	Plum Creek Underground Water	\$36,210	\$6.52	\$6.52	\$0.00	\$0.00	\$0.00	\$0.00
2008	Plum Creek Conservation District	\$36,210	\$6.52	\$6.52	\$0.00	\$0.00	\$0.00	\$0.00
2008	Farm to Market Road	\$36,210	\$0.11	\$0.11	\$0.00	\$0.00	\$0.00	\$0.00
2008	Caldwell County	\$36,210	\$250.10	\$250.10	\$0.00	\$0.00	\$0.00	\$0.00
	2008 TOTAL:		\$705.91	\$705.91	\$0.00	\$0.00	\$0.00	\$0.00
2007	Farm to Market Road	\$34,970	\$0.14	\$0.14	\$0.00	\$0.00	\$0.00	\$0.00
2007	Caldwell County	\$34,970	\$238.95	\$238.95	\$0.00	\$0.00	\$0.00	\$0.00
2007	Lockhart ISD	\$34,970	\$420.34	\$420.34	\$0.00	\$0.00	\$0.00	\$0.00
2007	Plum Creek Conservation District	\$34,970	\$6.22	\$6.22	\$0.00	\$0.00	\$0.00	\$0.00
2007	Plum Creek Underground Water	\$34,970	\$6.29	\$6.29	\$0.00	\$0.00	\$0.00	\$0.00
	2007 TOTAL:		\$671.94	\$671.94	\$0.00	\$0.00	\$0.00	\$0.00
2006	Farm to Market Road	\$40,650	\$0.20	\$0.20	\$0.00	\$0.00	\$0.00	\$0.00
2006	Caldwell County	\$40,650	\$261.46	\$261.46	\$0.00	\$0.00	\$0.00	\$0.00
2006	Lockhart ISD	\$40,650	\$626.02	\$626.02	\$0.00	\$0.00	\$0.00	\$0.00
2006	Plum Creek Conservation District	\$40,650	\$6.99	\$6.99	\$0.00	\$0.00	\$0.00	\$0.00
2006	Plum Creek Underground Water	\$40,650	\$7.11	\$7.11	\$0.00	\$0.00	\$0.00	\$0.00
	2006 TOTAL:		\$901.78	\$901.78	\$0.00	\$0.00	\$0.00	\$0.00
2005	Lockhart ISD	\$40,290	\$680.90	\$680.90	\$0.00	\$0.00	\$0.00	\$0.00
2005	Plum Creek Underground Water	\$40,290	\$7.61	\$7.61	\$0.00	\$0.00	\$0.00	\$0.00
2005	Plum Creek Conservation District	\$40,290	\$6.93	\$6.93	\$0.00	\$0.00	\$0.00	\$0.00
2005	Farm to Market Road	\$40,290	\$0.24	\$0.24	\$0.00	\$0.00	\$0.00	\$0.00
2005	Caldwell County	\$40,290	\$253.46	\$253.46	\$0.00	\$0.00	\$0.00	\$0.00
	2005 TOTAL:		\$949.14	\$949.14	\$0.00	\$0.00	\$0.00	\$0.00
2004	Lockhart ISD	\$35,320	\$561.13	\$561.13	\$0.00	\$0.00	\$0.00	\$0.00
2004	Plum Creek Underground Water	\$35,320	\$6.68	\$6.68	\$0.00	\$0.00	\$0.00	\$0.00
2004	Plum Creek Conservation District	\$35,320	\$5.83	\$5.83	\$0.00	\$0.00	\$0.00	\$0.00
2004	Farm to Market Road	\$35,320	\$0.25	\$0.25	\$0.00	\$0.00	\$0.00	\$0.00
2004	Caldwell County	\$35,320	\$211.39	\$211.39	\$0.00	\$0.00	\$0.00	\$0.00
	2004 TOTAL:		\$785.28	\$785.28	\$0.00	\$0.00	\$0.00	\$0.00
2003	Farm to Market Road	\$39,230	\$0.31	\$0.31	\$0.00	\$0.00	\$0.00	\$0.00
2003	Caldwell County	\$39,230	\$222.28	\$222.28	\$0.00	\$0.00	\$0.00	\$0.00
2003	Lockhart ISD	\$39,230	\$574.88	\$574.88	\$0.00	\$0.00	\$0.00	\$0.00
2003	Plum Creek Conservation District	\$39,230	\$6.87	\$6.87	\$0.00	\$0.00	\$0.00	\$0.00
2003	Plum Creek Underground Water	\$39,230	\$7.85	\$7.85	\$0.00	\$0.00	\$0.00	\$0.00
	2003 TOTAL:		\$812.19	\$812.19	\$0.00	\$0.00	\$0.00	\$0.00
2002	Plum Creek Conservation District	\$279,390	\$48.89	\$48.89	\$0.00	\$0.00	\$0.00	\$0.00
2002	Lockhart ISD	\$279,390	\$4020.70	\$4020.70	\$0.00	\$0.00	\$0.00	\$0.00
2002	Caldwell County	\$279,390	\$1508.71	\$1508.71	\$0.00	\$0.00	\$0.00	\$0.00
2002	Farm to Market Road	\$279,390	\$2.51	\$2.51	\$0.00	\$0.00	\$0.00	\$0.00
	2002 TOTAL:		\$5580.81	\$5580.81	\$0.00	\$0.00	\$0.00	\$0.00
	GLENVOIR FARM TOTAL:		\$18207.42	\$18227.42	\$0.00	\$0.00	\$0.00	\$0.00

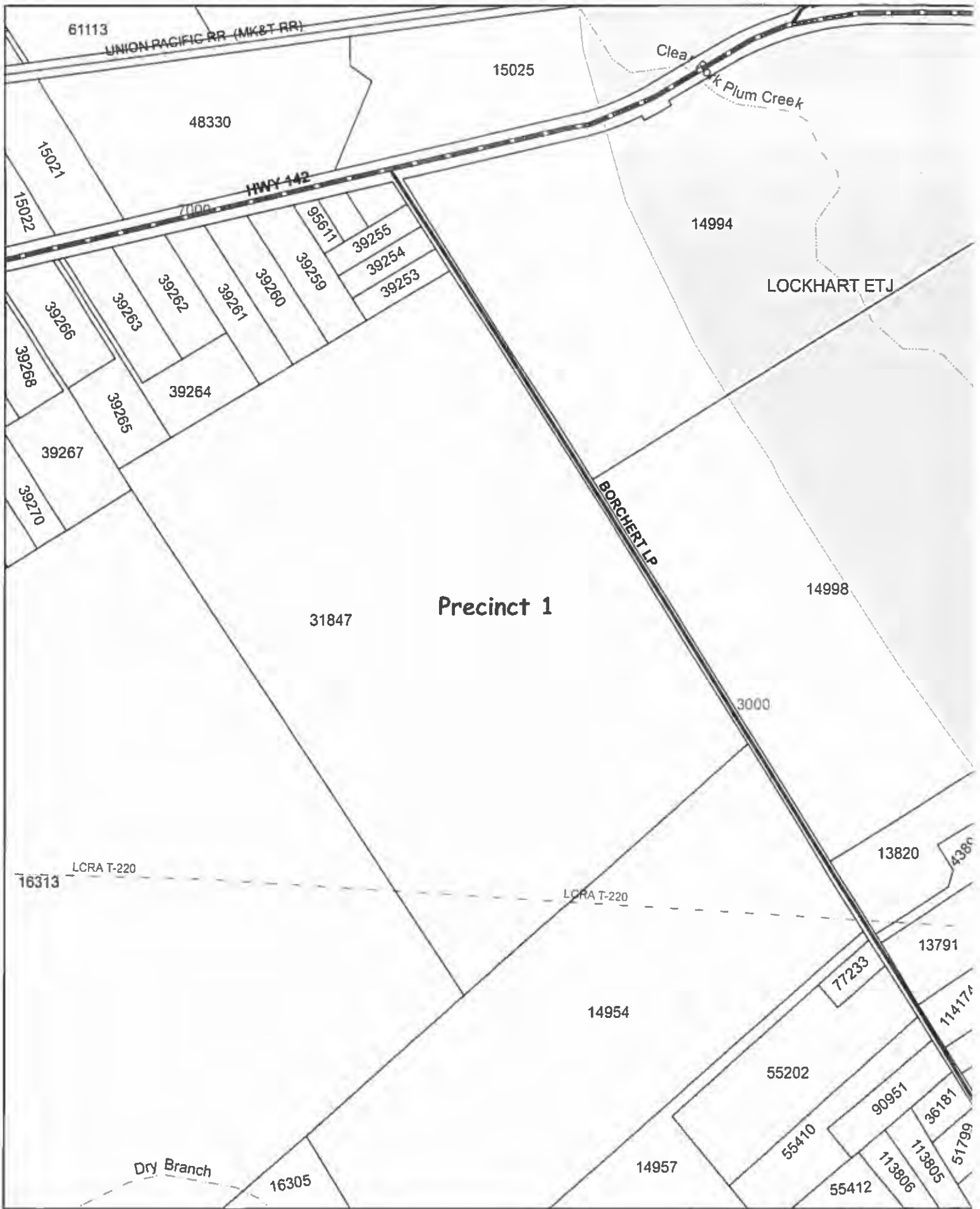

This map is being provided as a courtesy and should only be used as a general guide. It is not a guarantee of location, configuration, size or title. No warranty is expressed or implied to any user for any purpose.

This product is for informational purposes and may not have been prepared for or be suitable for legal, engineering, or surveying purposes. It does not represent an on-the-ground survey and represents only the approximate relative location of property boundaries.

Date Printed
Tuesday, May 07, 2019

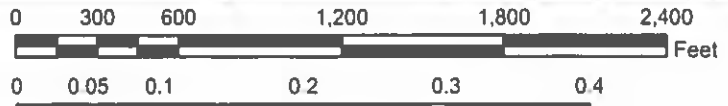

29. Discussion/ Action to consider the approval of the Preliminary Plat for Hartland Ranch Subdivision to include 20 lots on approximately 177.5 acres located on Borchert Loop. **Cost: None.**
Speaker: Commissioner Westmoreland /Kasi Miles. Backup:
32

Caldwell County Agenda Item Request Form

To: All Elected Officials and Department Heads – Hand deliver or scan & email to hoppy.haden@co.caldwell.tx.us and ezzy.chan@co.caldwell.tx.us . Deadline is 5:00 pm Tuesday before the Regular meetings, however, please submit this completed form ASAP. "Anything missing will cause the Agenda Item to be held over to the next Regular meeting," according to our Rules & Procedures.

AGENDA DATE: 5/13/19

Type of Agenda Item

- Consent
- Discussion/Action
- Executive Session
- Workshop
- Public Hearing

What will be discussed? What is the proposed motion?
Approval for Preliminary Plat for Hartland Ranch

1. Costs:

Actual Cost or Estimated Cost \$ 0

Is this cost included in the County Budget? n/a

Is a Budget Amendment being proposed? n/a

2. Agenda Speakers:

	Name	Representing	Title
(1)	Kasi Miles	Caldwell County	Director of Sanitation
(2)			
(3)			

3. Backup Materials: None To Be Distributed 32 total # of backup pages (including this page)

Approved by phone:

4. Commissioner Westmoreland 5-7-19
Signature of Court Member Date

LEGEND

- 1. 176.60 ACRES OF LAND
- 2. 177.5 ACRES OF LAND
- 3. 177.5 ACRES OF LAND
- 4. 177.5 ACRES OF LAND
- 5. 177.5 ACRES OF LAND

PROPERTY

- 1. 176.60 ACRES OF LAND
- 2. 177.5 ACRES OF LAND
- 3. 177.5 ACRES OF LAND
- 4. 177.5 ACRES OF LAND
- 5. 177.5 ACRES OF LAND

HARTLAND RANCH

176.60 ACRES IN THE W.C. STEFFEY SURVEY, ABSTRACT NO. 274 AND IN THE M. HUNT SURVEY, ABSTRACT NO. 137 IN CALDWELL COUNTY, TEXAS.

Preliminary Subdivision Plat

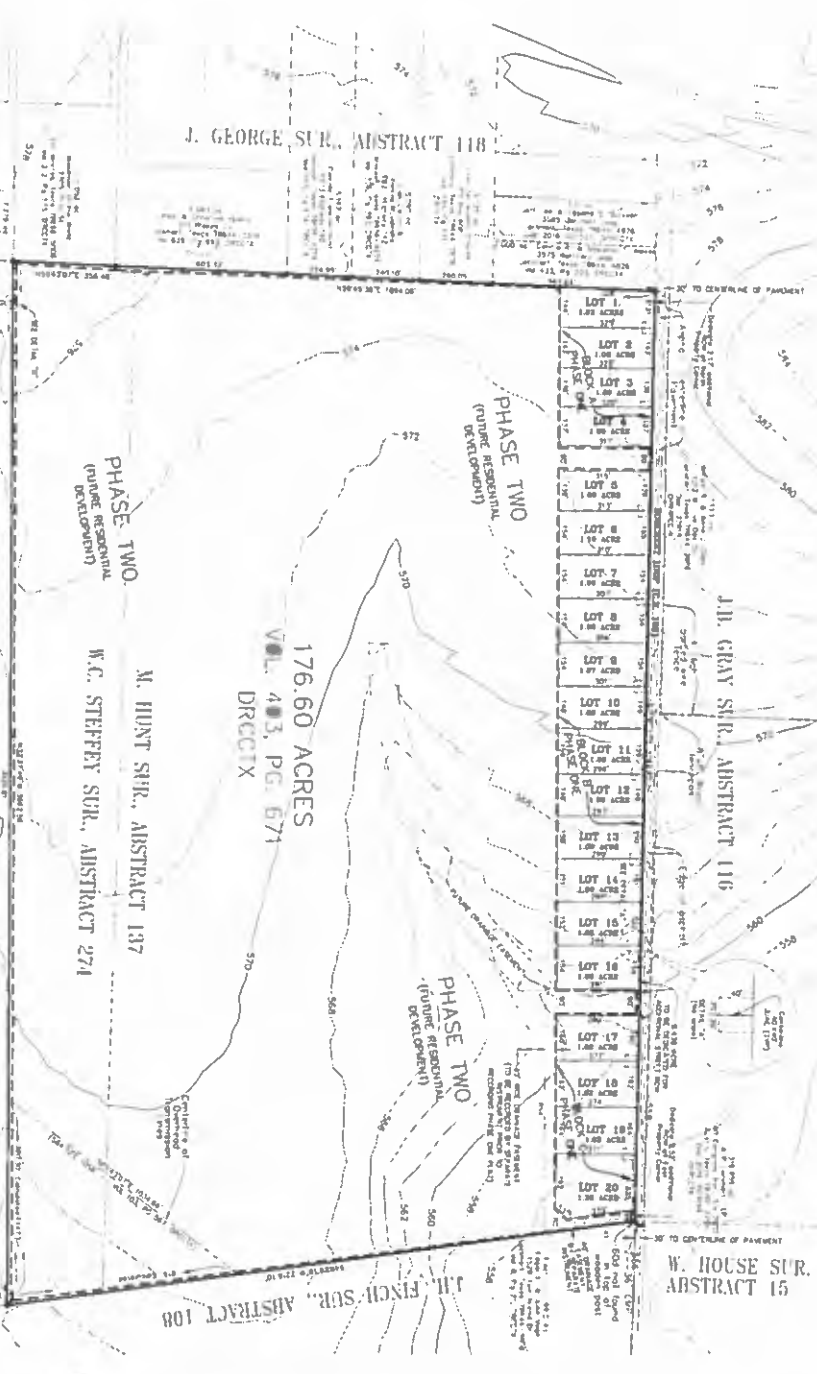

LEGAL DESCRIPTION:
 176.60 ACRES OF LAND CONSISTING OF A CALLED 35.0 ACRES OF LAND, DESCRIBED AS FOURTH TRACT IN THE W. C. STEFFEY SURVEY, ABSTRACT NUMBER 274 IN CALDWELL COUNTY, TEXAS; AND CONSISTING OF A CALLED 142.5 ACRES OF LAND, DESCRIBED AS FIFTH TRACT IN THE M. HUNT SURVEY, ABSTRACT NUMBER 137 IN CALDWELL COUNTY, TEXAS; SAID CALLED 177.5 ACRES OF LAND BEING A PORTION OF A 494.8 ACRE TRACT OF LAND CONVEYED IN A DEED TO WILLIAM JANNLEY GAMBLE, TRUSTEE OF THE KAIL THOMPSON JANNLEY REVOCABLE TRUST "A" AND RECORDED IN VOLUME 403, PAGE 671 OF THE DEED RECORDS OF CALDWELL COUNTY, TEXAS.

BEARING BASIS IS NAD83, TEXAS STATE PLANE COORDINATE SYSTEM, TEXAS SOUTH CENTRAL ZONE 4. ONLY PERIMETER BOUNDARY PROPERTY CORNERS OF THIS 176.58 ACRE TRACT HAVE BEEN LOCATED OR SET FOR THIS PRELIMINARY PLAT.

AREA TABULATION:

PHASE ONE	4.092 ACRES
BLOCK A	12.455 ACRES
BLOCK B	4.371 ACRES
BLOCK C	4.39 ACRES
ROW BORCHERT LOOP	21.357 ACRES
SUBTOTAL	21.357 ACRES
PHASE TWO	155.247 ACRES
TOTAL AREA	176.60 ACRES

ACCORDING TO THE FEDERAL EMERGENCY MANAGEMENT AGENCY, NFIP FLOOD INSURANCE RATE MAP NOS. 48015C0150E AND 48055C0250E FOR CALDWELL COUNTY, TEXAS DATED JUNE 19, 2012, THE TRACT SURVEYED HEREON APPEARS TO BE IN "OTHER AREAS - ZONE X" (AREAS DETERMINED TO BE OUTSIDE THE 0.2% ANNUAL CHANCE FLOODPLAIN)

PRELIMINARY. THIS DOCUMENT SHALL NOT BE RECORDED FOR ANY PURPOSE.

SUBMITTED:
 REVIEWED:

THE MOORE GROUP
 1577 FRENCH BLVD., SUITE 200
 FORT WORTH, TEXAS 76104
 PHONE: 817-335-1111
 FAX: 817-335-1112

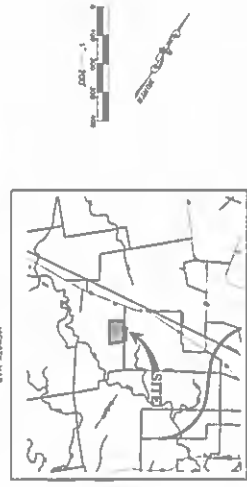

April 25, 2019

Kasi Miles
Caldwell County
1700 FM 2720
Lockhart, TX 78644

RE: **Hartland Ranch – Preliminary Plat –
Information Submitted April 1, 2019
BCG Project No. 070004-68-001**

Ms. Miles,

Bowman Consulting has completed its review of the additional information submitted for the preliminary plat for Hartland Ranch on April 1, 2019.

The Preliminary Plat appears to be in general conformance with the rules and regulations of Caldwell County; and, we recommend placing the plat on the Commissioners Court agenda for consideration.

Please feel free to call me if you have any questions.

It is our pleasure to be of assistance to the County on this project.

Sincerely,



Charles R. Wirtanen, P.E.
Bowman Consulting Group, Ltd.



Fax (512) 357-0152
PO Box 158 Maxwell, TX 78656
www.maxwellwsc.com

Kasi L. Miles
Director of Sanitation
1700 FM 2720
Lockhart, TX 78644

Re: Water service to twenty (20) residential lots.

Ms. Miles,

The developer of Hartland Ranch has requested water service to twenty (20) lots that are on Borchart Loop.

Maxwell Water Supply has sufficient capacity to serve these twenty (20) new connections. Actual water service is pending the execution of a Non-Standard Service Agreement.

Please call if you have any questions regarding this letter. 512.757.4104

CC; Jared Jakovich by email.



Austin Ivicic
General Manager



May 7, 2019

Jared Jakovich
Lockhart, TX

**Re: Service Availability – Hartland Ranch (PID#31847 – 177.5 Ac.), Lockhart, TX –
Caldwell County**

To Whom It May Concern:

We have determined that the location of your inquiry in Caldwell County is in the certificated service territory of Bluebonnet Electric Cooperative, Inc. and we are therefore willing to provide electric service. Bluebonnet's promise to provide service is contingent upon the applicant fulfilling all the requirements of our Tariff including our Line Extension Policy.

Should you have any questions or need additional information, please give me a call at 979-542-8518.

Sincerely,

Shawn Ely

Shawn Ely, PMP
Electric Distribution Design Supervisor

RE: Development Names in Caldwell County

Matthew <matthewa@caldwellcad.org>

Mon 4/29/2019 12:17 PM

To: Kasi Miles <miles479@hotmail.com>; Jacki <jaclyna@caldwellcad.org>

These subdivision names below appear to okay with no duplicates.

Esperanza

Hartland Ranch or Hartland Ranch Estates (I would recommend NOT adding or removing Estates if this is a multiple Phase subdivision)

Clear Fork Ranch (There are some inside City of Lockhart that are similar. Clear Fork Addn, Clear Fork Estates, The Meadows of Clear Fork)

Thank You,

Matthew Allen, R.P.A.

GIS Mapper / System Admin / Appraiser

Caldwell County Appraisal District

211 Bufkin Ln

P.O. Box 900

Lockhart, Texas 78644

Phone: 512-398-5550 x205

Website: www.caldwellcad.org



From: Kasi Miles [mailto:miles479@hotmail.com]

Sent: Thursday, April 18, 2019 7:36 AM

To: Jacki <jaclyna@caldwellcad.org>; Matthew <matthewa@caldwellcad.org>

Cc: Jared Jakovich <jared@jakovichperry.com>

Subject: Fw: Development Names in Caldwell County

Matthew / Jacki:

Can you please confirm that the following names in writing for Jared Jakovich....

Kasi

From: Jared Jakovich <jared@jakovichperry.com>
Sent: Wednesday, April 17, 2019 11:47 AM
To: kasi.miles@co.caldwell.tx.us
Cc: Jack Perry; Stephanie Van Arsdale
Subject: Development Names in Caldwell County

Kasi,

As discussed, we are changing plans for Murphy Ranch Section 2 and would like to meet with the county engineers to discuss a site development plan for a Manufactured Housing "space" rental community. We would like to insure that the name "Esperanza" is available for this development. In addition, please confirm in writing that the names we are using for the two Lockhart developments have been approved and reserved as well. They are "Hartland Ranch" (Phase II) and "Hartland Ranch Estates" (Phase I- 20 lots) on the 178 acres west of Borchert Loop, and "Clear Fork Ranch" on the 317 acres on the east side of Borchert Loop. If you have any questions and/or comments please call me. Thank you for your help with this.

Kindest Regards,

Jared L. Jakovich, President
Jakovich & Perry Capital Partners, LLC
100 Congress Avenue, Suite 2000
Austin, Texas 78701
(512) 469-5580 – Office
(512) 469-3711 – Fax
(512) 922-5145 – Mobile
jared@jakovichperry.com

**ENGINEER'S
&
DRAINAGE REPORT**

FOR

HARTLAND RANCH SUBDIVISION PHASE I

APRIL 2018



Edward C. Moore

Prepared by:

**The Moore Group
Texas Registered Engineering Firm # 249
1000 Cuernavaca
Austin, TX 78733**

INTRODUCTION: The Hartland Ranch Subdivision is a proposed 2-phase 177.5 acre single-family development located approximately 0.1 miles south of the intersection of Texas Highway 142 and Borchert Loop in Caldwell County, Texas. Phase I is currently planned to include 20 one-acre, single-family lots. At the time of the writing of this report, the scope of Phase II of the development has yet to be determined. This report is intended to be part of the preliminary plat application to Caldwell County for Phase I only. The project's road infrastructure will be maintained by Caldwell County and built according to Caldwell County standards with 60-foot local street ROW's, save for two site accesses located on Borchert Loop of 90-foot local street ROW's. A detail of the road cross section is included in the plans accompanying this report. Water service will be provided by Maxwell Water Supply Corporation and electricity will be provided by the Bluebonnet Electric Cooperative. Sewer service will be by On-Site Sewage Facility (OSSF).

DRAINAGE REPORT: The subject site consists of topography in which the majority of runoff occurs towards an unnamed wet weather waterway running through the center of the tract. A much smaller area of the tract drains to the north of the site. See attached Drainage Plan for detailed drainage delineations.

For Phase I, proposed drainage conditions are to stay largely the same as those under existing drainage conditions save for a small drainage channel beginning at the existing road culvert located at a low-point in Borchert Loop and running along the east property line of Lot 4, Block C and finally parallel to the rear property lines of Lots 1-4, Block C. See attached Preliminary Plat and Drainage Plan for a depiction. Additional drainage considerations are to be included in the future phase.

HYDROLOGIC ANALYSIS: For the purposes of this analysis, hydrographs were developed for Phase 1 conditions using the industry standard SCS Curve Number Method as detailed in the United States Department of Agriculture's Technical Release 55. The US Army Corp of Engineers' HEC-HMS software was implemented to more effectively model site conditions and to aid in tedious calculations.

Below, results of the analysis are displayed for the 2, 10, 25, and 100-year storm events, showing runoff totals for Phase 1 conditions. Basin delineations are detailed in the attached Drainage Plan.

Subbasin	Runoff (cfs)			
	2 Year	10 Year	25 Year	100 Year
E1	131.59	269.22	348.38	478.88
E2	31.31	63.79	82.45	113.19
E3	1.92	3.90	5.03	6.90

FLOODPLAIN: No portion of this tract is located within the flood hazard area as designated by the Federal Flood Insurance Administration Rate Maps 48209C0420F dated September 2, 2005, 48055C0115E dated June 19, 2012, 48055C0225E June 19, 2012, and 48055C0220E June 19, 2012.

ROAD DESIGN: The roads will be maintained by Caldwell County and built to Caldwell County standards.

CONCLUSION: In the opinion of The Moore Group, the Borchert Loop Phase 1 177 Acre Subdivision plans meet Caldwell County requirements for approval. Therefore, we respectfully request approval of the proposed preliminary plat.

THE MOORE GROUP
ENGINEERING, SURVEYING AND CONSTRUCTION SERVICES
1000 CUERNAVACA DRIVE
AUSTIN, TEXAS 78733

TEXAS REGISTERED ENGINEERING FIRM # 249

March 29, 2019

Kasi Miles
Caldwell County
1700 FM 2720
Lockhart, TX 78644

Re: Request for Waiver from Buffer Zone Requirement
Hartland Ranch Subdivision – Preliminary Plat

Dear Ms. Miles:

With this letter, on behalf of the owner of Hartland Ranch, a proposed subdivision in Caldwell, County, I request approval of waiver from the Stream Setback buffer requirements of Appendix G1 of the Caldwell County Development Ordinance.

The waiver is justified for the following reasons: The wording of the ordinance anticipates that the stream is a defined waterway with "streambanks" that establish the line where the setback begins. However, although there is a the drainage area on the subject site that is 64+ acres, there is no defined stream bank to set back from. It seems the setback requirement was meant for defined creeks. Instead, this property has historically been farmed, is very flat, and the location of the 64 acre drainage is just where the farmer graded the land to pass stormwater. The property will be better served if the waiver is granted and subdivision drainage improvements can be designed to more efficiently convey the drainage.

For the reasons stated above, we request your approval of this waiver from the Stream Setback buffer requirements of Appendix G1 of the Caldwell County Development Ordinance for Hartland Ranch.

Sincerely,

Edward C. Moore

Edward C. Moore, P.E.
The Moore Group

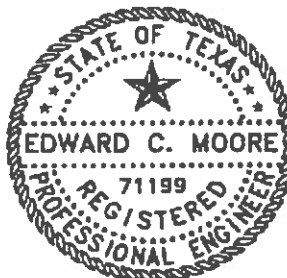

cc: Jared Jakovich, Developer

PHONE – 512-442-0377
FAX – 512-442-7807



March 8, 2018

Kasi Miles
Caldwell County
1700 FM 2720
Lockhart, TX 78644

RE: Hartland Ranch- Preliminary Plat- Review of Additional Drainage Information
Submitted February 8, 2019
BCG Project No. 070004-68-001

Dear Mr.Charles:

It is our understanding that the County has concerns regarding drainage issues as a result of the construction at the proposed developments of the 19 lots. It was observed by site inspection that there are two drainage basins onsite that will be effected by the proposed development. Their analysis points are referred to E1, E3, P1, and P2 in the drainage report amendment.

The increase in flow from E1 to P1 is 1.52 cfs. These analysis point discharges stormwater runoff towards the northern property line towards Borchert Loop. Currently there is no drainage ditch or drainage structures located at this analysis point. The increase in flow from E1 to P2 is 4.91. These analysis point discharges stormwater runoff towards the northeast property line towards Borchert Loop where it is conveyed under the roadway by two 36 inch culverts. The crossing has been analyzed to insure that the velocities and water surface elevations of the proposed development has no measurable change. Based on this analysis the difference in water surface elevation is 0.02 feet.

Based off the analysis conducted by M&S Engineering, the runoff produced from the development of the 19 lots is minimal and there will be no deleterious downstream impacts due to the increase. On behalf of the developer, we request a wavier for Hartland Ranch- Preliminary Plat detention requirement. No detention is required because the proposed development has no downstream impacts. The referenced drainage report amendment conducted by M&S Engineering has been attached to this letter for reference. If you have any questions or require additional information, please call me at (830)629-2988.

Sincerely,



2019-03-12

Trevor Tast, P.E.
M & S Engineering, L.L.C.



March 8, 2018

Kasi Miles
Caldwell County
1700 FM 2720
Lockhart, TX 78644

RE: Hartland Ranch- Preliminary Plat- Review of Additional Drainage Information
Submitted February 8, 2019
BCG Project No. 070004-68-001

M&S Engineering is resubmitting the Hartland Ranch- Preliminary Plat for approval at this time. Comments were received on March 5, 2019 and have been addressed. An updated set calculations and the drainage report are attached to this submittal. The following are how the comments were addressed:

1. Calculations have been added to the report to show that the culvert crossing water surface elevation at analysis point E1/P1 are below 0.05 feet. This shows that there is no measurable change due to the proposed development.
2. A letter and drainage report is attached to this response letter and the requested statement in regarded to the change in flow being minimum and will be no deleterious downstream impacts due to the increase has been added to the letter and report.
3. This comment has been noted. When future development detention takes place existing condition will be the land before the 19 lots were developed ,
4. The plat title is Harland Ranch. There is not plat name Borchert Loop anymore.

If you have any questions or require additional information, please call me at (830)629-2988.

Sincerely,

Trevor Tast, P.E.
M & S Engineering, L.L.C.

Cc: File

STORMWATER MANAGEMENT STUDY & DOWNSTREAM IMPACT ANALYSIS

For

Hartland Ranch Subdivision Phase 1

Addendum #1

Prepared for:

Jakovich & Perry Capital Partners LLC

Prepared by:

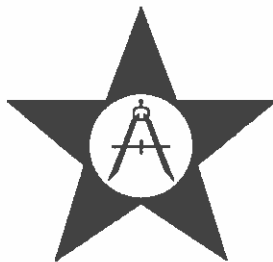

M&S ENGINEERING
CIVIL | ELECTRICAL | STRUCTURAL | MECHANICAL

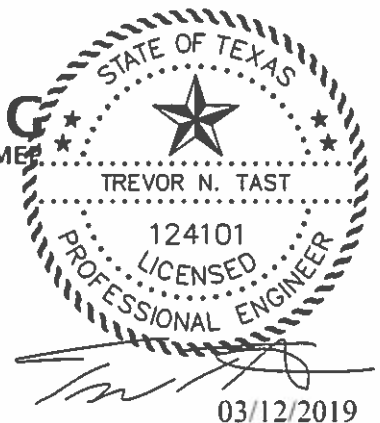

M&S Engineering Project Number: 7018JPCAP.001

Main Office:

Mailing:

Post Office Box 970
Spring Branch, Texas 78070
Telephone: 830.228.5446
Fax: 830.885.2170

Physical:

6477 FM 311
Spring Branch, Texas 78070
Web: www.msengr.com

Branch Office:

376 Landa Street
New Braunfels, TX 78130
Telephone: 830.629.2988
Fax: 830.228.4197

Prepared by:

Trevor Tast., P.E.
Jeremy More, E.I.T.
M&S Engineering, L.L.C.
Texas Registered Engineering Firm F-1394

February 2019



I. TABLE OF CONTENTS

I.	Table of Contents	i
II.	List of Figures	ii
III.	Executive Summary	1
IV.	Hydrology	2
	<i>Existing Conditions</i>	2
	<i>Proposed Conditions</i>	3
V.	Appendix A: Maps and Exhibits	
VI.	Appendix B: Hydrologic Calculations	
VII.	Appendix C: Hydrologic Modeling	



II. LIST OF FIGURES

Table IV-1: Discharge Summary Tables 3



III. EXECUTIVE SUMMARY

Hartland Ranch is a 177.5-acre tract of land that is located Caldwell County, Texas. This site is located approximately 0.1 miles south of the intersection of Texas Highway 142 and Borchers Loop. The property is currently zoned for single family development. The site lies in Zone X on the FEMA Floodplain panel 48209C0420F (Eff. September 2, 2005), 48055C0115E (Eff. June 19, 2012), 48055C0225E (Eff. June 19, 2012), and 48055C0220E (Eff. June 19, 2012). Zone X is described as areas determined to be outside the 0.2% annual chance floodplain.

The existing site is an undeveloped tract of land consisting of cultivated farmland, native grasses and open fields with sparse brush and tree cover. The 177.5-acre property has three analysis points for stormwater runoff. The site generally conveys stormwater runoff to the East property line and South property line. A small portion of the site drainages to the north of the site. The analysis points were analyzed in the Hartland Ranch Subdivision Phase I Engineer's and Drainage Report By The Moore Group in April 2018.

The report completed by the Moore Group provided existing condition analysis only. This addendum will focus on a comparative analysis between existing and proposed conditions. This report is an addendum to the current report; drainage areas E1 and E3 will be reanalyzed based on the development the 20 lots located to the northeast boundary of the site. In addition, a proposed drainage channel will be placed on the back side of the last four lots to divert stormwater runoff from a natural channel currently in drainage area E1. Peak flow rate were reanalysis for the 2, 10, 25, and 100-year storm events. Based on the analysis proposed conditions for the site will remain constant with existing conditions and any increase due to development will be negligible. Phase 1 development of the subdivision does not have any proposed improvements associated with drainage basin E2 and therefore is not being re-analyzed.

It is shown throughout the text and attached appendices that the analysis points have been analyzed using the SCS Curve Number Method as detailed in the United States Department of Agriculture's Technical Release 55. Hydraflow Hydrographs, an extension for AutoCAD Civil 3D 2019 was utilized to model the stormwater flow rates for the watersheds.



IV. HYDROLOGY

The Existing and Proposed peak flow discharges were calculated at points of interest using the SCS method. This method was used to conform to the currently approved study. The basins that will be reanalyzed are E1 and E3. Basin E2 will have no changes to the conditions from existing to propose so there will be no increase in flow. The overall watershed boundaries for both the existing (from The Moore Group Drainage Report) and proposed conditions are attached in Appendix A.

Time of concentration (TOC) calculations were completed the SCS Curve Number Method as detailed in the United States Department of Agriculture's Technical Release 55. This methodology includes the analysis for sheet, shallow concentrated and channel flow from the upper regions to the discharge point for each overall watershed boundary. Area watersheds and time of concentration paths were delineated using one-foot LIDAR contours, a detailed survey, and aerial photography. TOC calculations for the proposed conditions are provided in Appendix B.

Hydraflow Hydrographs, an extension for AutoCAD Civil 3D 2019 was utilized to model the stormwater flow rates for the watersheds. The input parameters for the modeling software were calculated using the methodology described in the preceding text. The complete hydraulic model is included in Appendix C.

EXISTING CONDITIONS

Hartland Ranch is a 177.5-acre tract of land that is located Caldwell County, Texas. This site is located approximately 0.1 miles south of the intersection of Texas Highway 142 and Borcher Loop. The property is currently zoned for single family development. The site lies in Zone X on the FEMA Floodplain panel 48209C0420F (Eff. September 2, 2005), 48055C0115E (Eff. June 19, 2012), 48055C0225E (Eff. June 19, 2012), and 48055C0220E (Eff. June 19, 2012). Zone X is described as areas determined to be outside the 0.2% annual chance floodplain.

The existing site is an undeveloped tract of land consisting of cultivated farmland, native grasses and open fields with sparse brush and tree cover. The 177.5-acre property has three analysis points for stormwater runoff. The site generally conveys stormwater runoff to the East property line and South property line. A small portion of the site drainages to the north of the site. The analysis points were analyzed in the Hartland Ranch Subdivision Phase I Engineer's and Drainage Report By The Moore Group in April 2018.

Drainage area E1 discharges approximately 158.84 acres of an offsite watershed to the east of the development. The 100-year peak total flow rate as calculated is 478.88 cfs. Drainage area E2 discharges approximately 1.315 acres of offsite watershed to the north of the development. The 100-year peak flow rate as calculated is 6.90 cfs. All stormwater is routed to the analysis points via overland flow. Table IV-1 shows a complete summary of the flow rates for all the design storms.



PROPOSED CONDITIONS

The proposed development consists of an addendum to the current report; drainage areas E1 and E3 will be reanalyzed based on the development the 20 lots located to the northeast boundary of the site. In addition, a proposed drainage channel will be placed on the back side of the last four lots to divert stormwater runoff from a natural channel currently in drainage area E1. The drainage area for the proposed conditions are identified as P1-1, P1-2, and P3.

Drainage area P1 drains 158.58 acres of the watershed through the East side of the property. The offsite water will be conveyed through the site through a proposed channel. E1 is the comparable flowrates for runoff to the northwest side of the property line. The 100-year peak flow rate as calculated to be 483.79 cfs in proposed conditions. The increase in runoff is 4.91 to 7.38 (0.26% to 1.16%). The increase of runoff is negligible. Table IV-1 shows a complete summary of the flow rates for all the design storms.

Drainage area P3 drains 1.315 acres of the watershed through the North property line. E3 is the comparable flowrates for runoff to the North property line. The 100-year peak flow rate as calculated to be 8.421cfs in proposed conditions. The increase in runoff is 0.63 to 1.52 (4.96% to 7.07%). The increase of runoff is negligible. Table IV-1 shows a complete summary of the flow rates for all the design storms.

Table IV-1: Discharge Summary Tables

Condition	Subbasin	Area (ac)	Time of Conc. (min)	Curve Number	Runoff (cfs)			
					2 Year	10 Year	25 Year	100 Year
Existing	E1	158.84	84.07	89	131.59	269.22	348.38	478.88
Proposed	P1	158.84	84.07	90.1	137.83	276.60	355.41	483.79
Difference (cfs)					6.24	7.38	7.03	4.91
Difference (%)					1.16	0.68	0.50	0.26
Existing	E3	1.315	18.43	89	1.92	3.90	5.03	6.90
Proposed	P3	1.315	18.43	92	2.55	4.92	6.25	8.42
Differnet (cfs)					0.63	1.02	1.22	1.52
Percent Different (%)					7.07	5.76	5.40	4.96



V. APPENDIX A: MAPS AND EXHIBITS

Appendix A.1: Location Map

Appendix A.2: Aerial Map

Appendix A.3: USGS Map

Appendix A.4: FEMA Firm Panel Exhibit

Appendix A.5: Existing Drainage Map

Appendix A.6: Proposed Drainage Map

Appendix A.7: Drainage Report (The Moore Group April 2018)

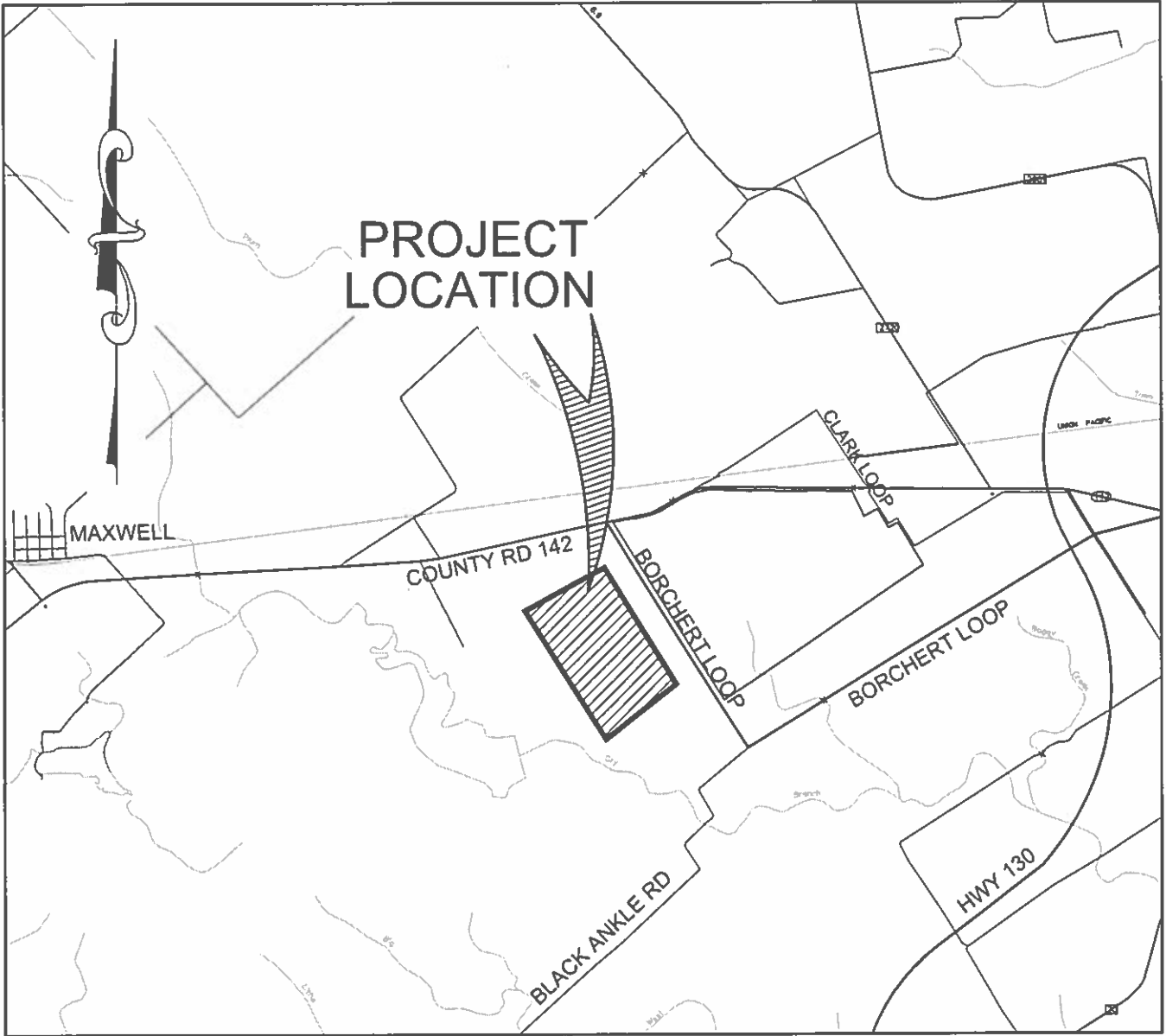

APPENDIX E.1

LOCATION MAP



APPENDIX E.2

AERIAL MAP

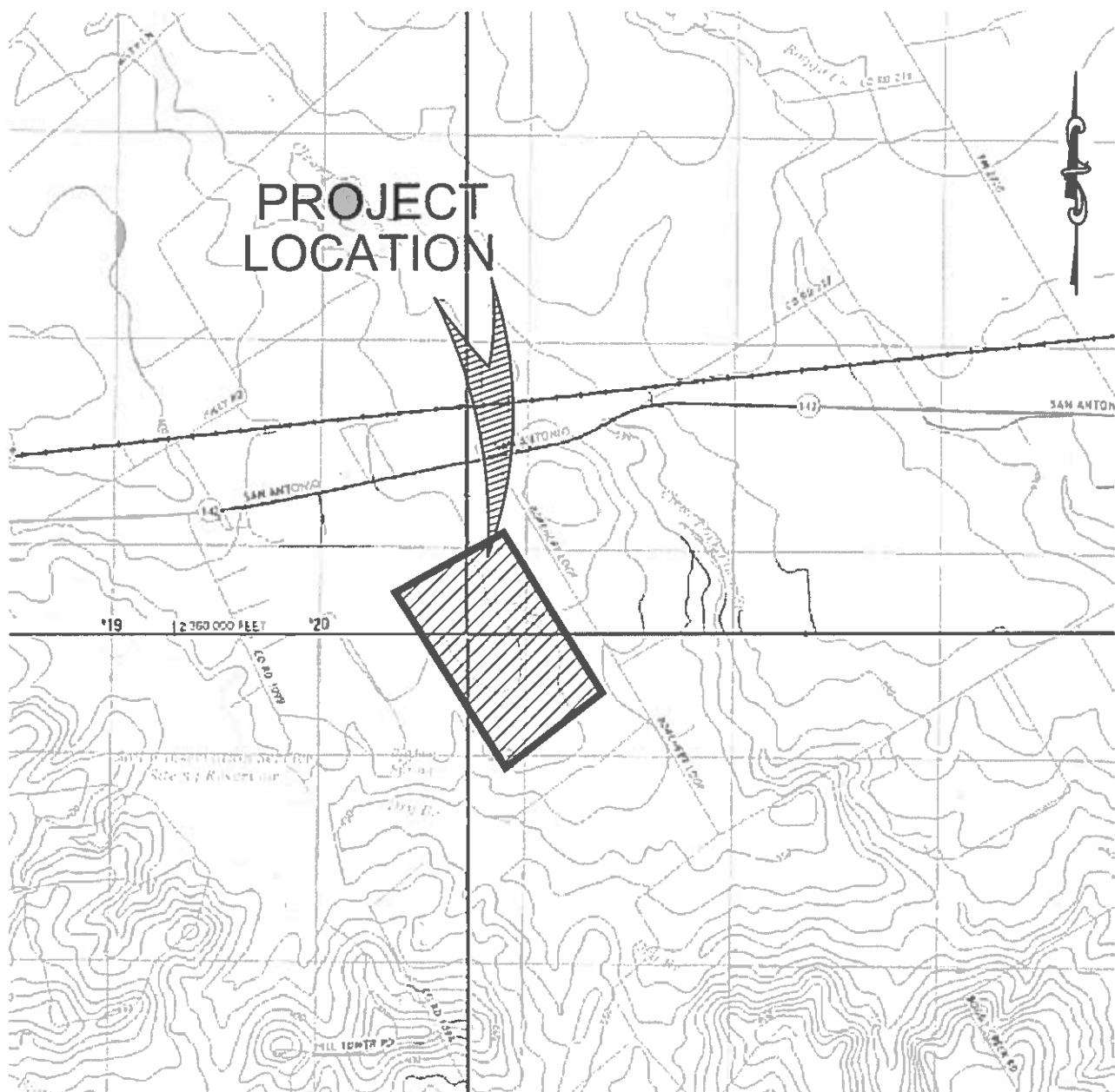

APPENDIX E.3

USGS MAP

PROJECT LOCATION

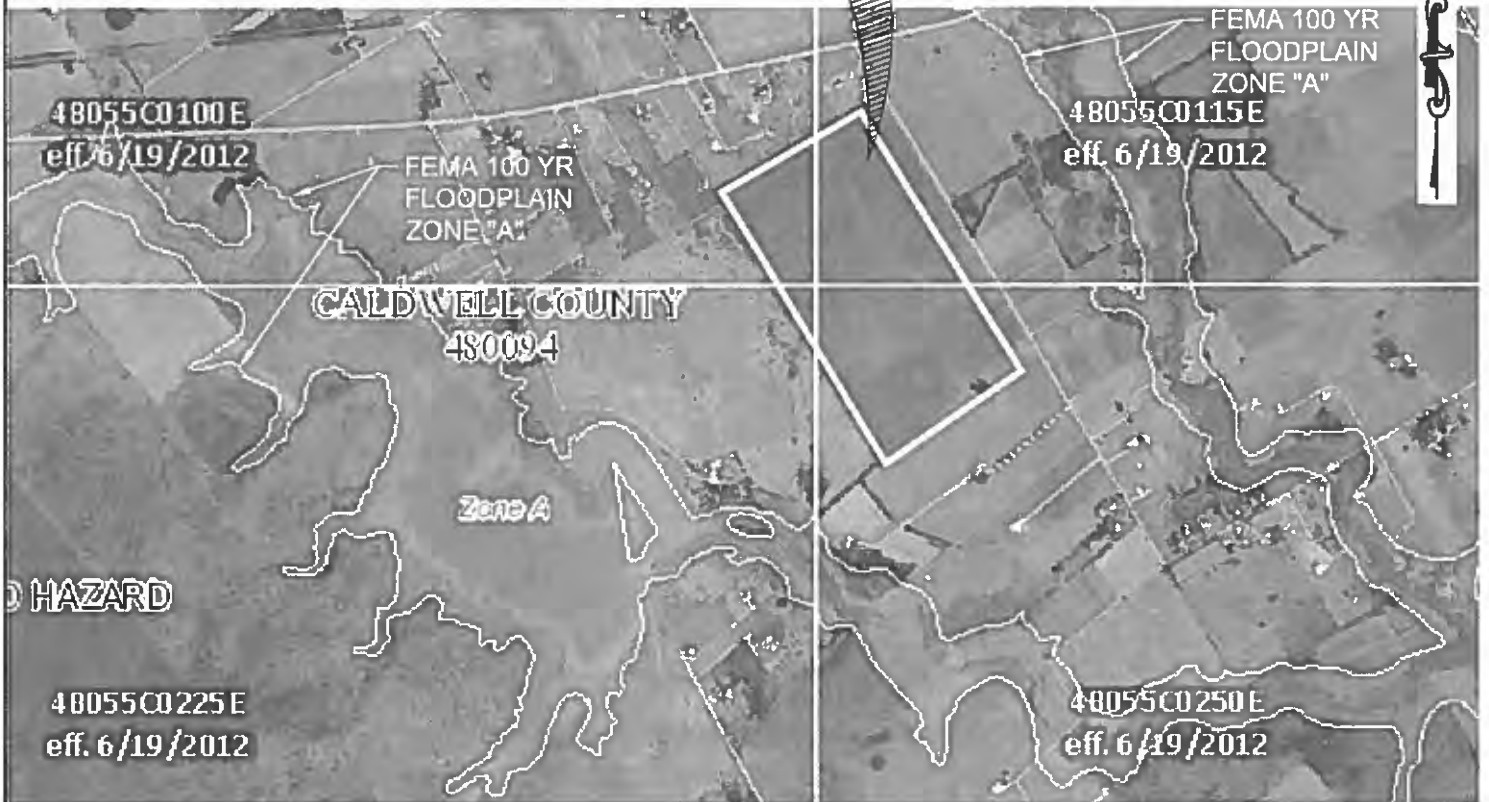

APPENDIX E.4

FLOODPLAIN MAP

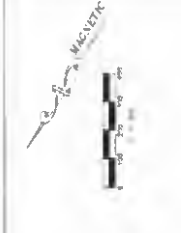

- LEGEND**
- 15' FB CHANNEL @ 0.50% PER DETAIL ON THIS SHEET
 - EXISTING DRAINAGE
 - PROPOSED DRAINAGE
 - PROPERTY BOUNDARY
 - EXISTING CONTOUR
 - PROPOSED CONTOUR
 - EXISTING TREE TO REMAIN
 - EXISTING TREE TO BE REMOVED
 - PROPOSED DRAINAGE DITCH
 - LINE OF CONSTRUCTION LINE
 - DRAINAGE BASIN INFORMATION

TIME OF CONCENTRATION CALCULATIONS

Area	Area (Ac)	Time (Min)	Weighted Time (Min)	Sum of Weighted Times (Min)	Time of Concentration (Min)
1	1.30	15	19.5	19.5	15
2	1.02	15	15.3	34.8	15
3	1.02	15	15.3	50.1	15
4	1.30	15	19.5	69.6	15
Total	4.64				15

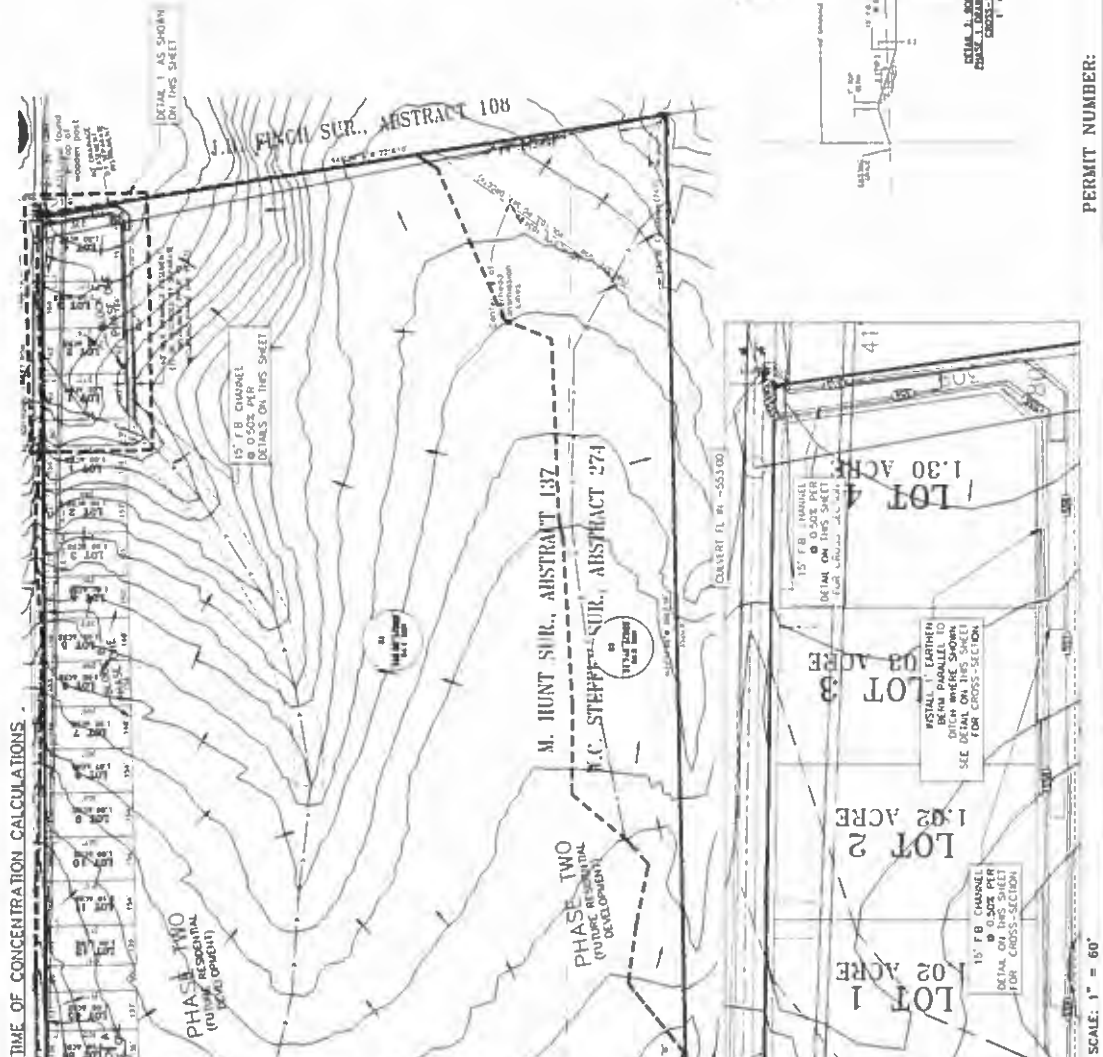

PEAK FLOWS SUMMARY TABLE (AND REC-HMS INPUTS)

Substation	Area (Ac)	Time of Conc. (Min)	Curve Number	Peak Flow (cfs)	Time of Conc. (Min)	Peak Flow (cfs)
1	1.30	15	0.75	11.5	15	11.5
2	1.02	15	0.75	8.5	15	8.5
3	1.02	15	0.75	8.5	15	8.5
4	1.30	15	0.75	11.5	15	11.5
Total	4.64			38.0		38.0



PERMIT NUMBER:

SCALE: 1" = 60'

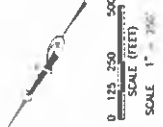

LEGEND:
 AREA TO BE DRAINAGE
 PROPOSED DRAINAGE
 PROPOSED DRAINAGE
 PROPOSED DRAINAGE

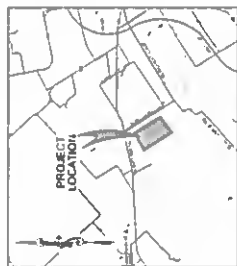
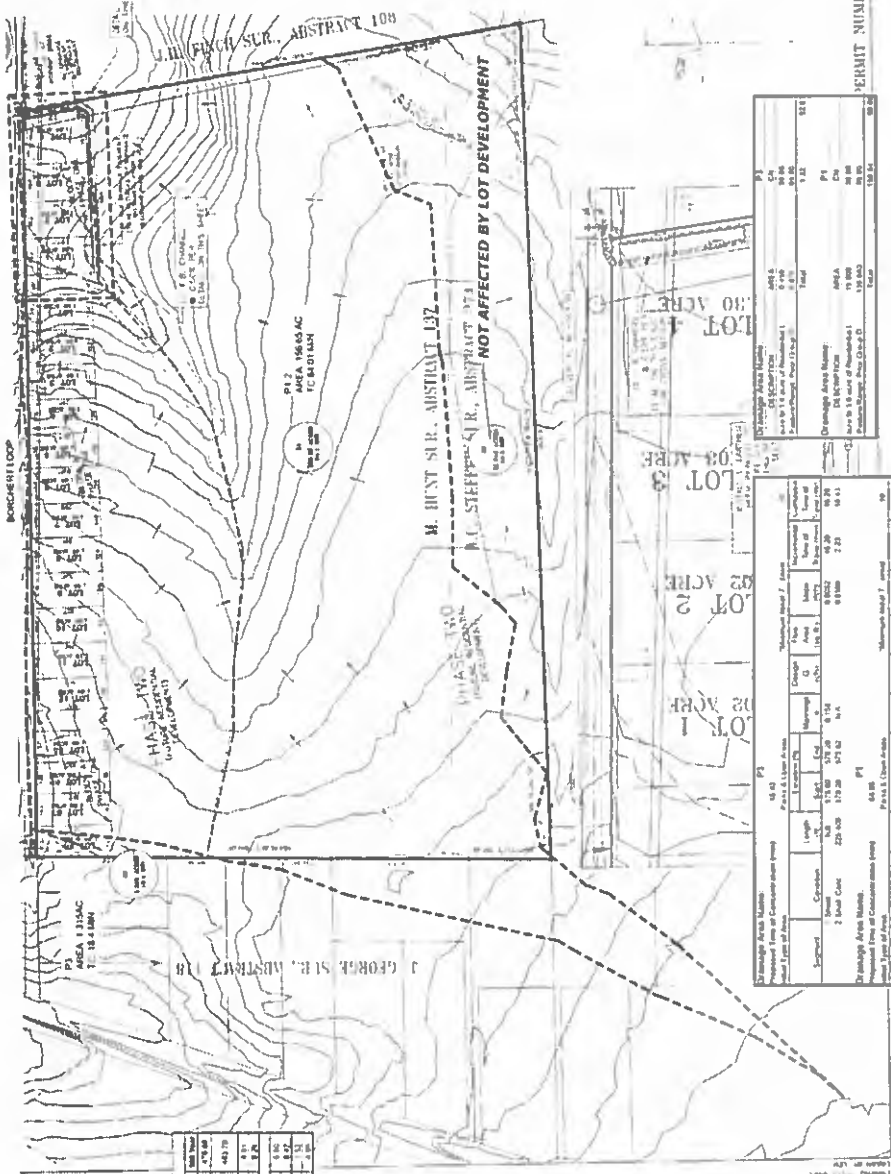

Station	Station	Station	Station	Station	Station	Station	Station	Station	Station
0+00	0+25	0+50	0+75	1+00	1+25	1+50	1+75	2+00	2+25
0+00	0+25	0+50	0+75	1+00	1+25	1+50	1+75	2+00	2+25

Drainage Area Name	Area (Acres)	Permit Number
P1	1.22	158-54
P2	1.22	158-54
P3	1.22	158-54
Total	3.66	

Drainage Area Name	Area (Acres)	Permit Number
P1	1.22	158-54
P2	1.22	158-54
P3	1.22	158-54
Total	3.66	

Small text at the bottom of the page, likely containing copyright or disclaimer information.

Caldwell CAD

Property Search Results > 31847 J & P LOCKHART BUILDERS LP for Tax year 2019
Year 2019

Property

Account

Property ID:	31847	Legal Description:	A137 HUNT, MEMUCAN, ACRES 177.5, 142.5 AC. IN HUNT A-137; 35 AC IN STEFFY A-274
Geographic ID:	0200137-100-000-00	Zoning:	
Type:	Real	Agent Code:	ID:225873
Property Use Code:			
Property Use Description:			

Location

Address:	BORCHERT LP LOCKHART, TX 78644	Mapsc0:	03-398
Neighborhood:	RURAL SE RIVER RD-DICKERSON RD-BORCHERT LP AREA	Map ID:	03-398
Neighborhood CD:	4130		

Owner

Name:	J & P LOCKHART BUILDERS LP	Owner ID:	222604
Mailing Address:	C/O JAKOVICH JARED 2814 BORCHERT LOOP LOCKHART, TX 78644-4823	% Ownership:	100.0000000000%
		Exemptions:	

Values

(+) Improvement Homesite Value:	+	\$0	
(+) Improvement Non-Homesite Value:	+	\$0	
(+) Land Homesite Value:	+	\$0	
(+) Land Non-Homesite Value:	+	\$794,160	Ag / Timber Use Value
(+) Agricultural Market Valuation:	+	\$0	\$0
(+) Timber Market Valuation:	+	\$0	\$0

(=) Market Value:	=	\$794,160	
(-) Ag or Timber Use Value Reduction:	-	\$0	

(=) Appraised Value:	=	\$794,160	
(-) HS Cap:	-	\$0	

(=) Assessed Value:	=	\$794,160	

Taxing Jurisdiction

Owner: J & P LOCKHART BUILDERS LP
% Ownership: 100.0000000000%
Total Value: \$794,160

Entity	Description	Tax Rate	Appraised Value	Taxable Value	Estimated Tax
CAD	Caldwell Appraisal District	0.000000	\$794,160	\$794,160	\$0.00
CESD2	Caldwell County ESD #2	0.100000	\$794,160	\$794,160	\$794.16

FTM	Farm to Market Road	0.000100	\$794,160	\$794,160	\$0.79
GCA	Caldwell County	0.775200	\$794,160	\$794,160	\$6,156.32
SLH	Lockhart ISD	1.332360	\$794,160	\$794,160	\$10,581.07
WPC	Plum Creek Conservation District	0.023200	\$794,160	\$794,160	\$184.25
WUG	Plum Creek Underground Water	0.021400	\$794,160	\$794,160	\$169.95
	Total Tax Rate:	2.252260			
				Taxes w/Current Exemptions:	\$17,886.54
				Taxes w/o Exemptions:	\$17,886.55

Improvement / Building

No improvements exist for this property.

Land

#	Type	Description	Acres	Sqft	Eff Front	Eff Depth	Market Value	Prod. Value
1	NHS	NON HOMESITE	177.5000	7731900.00	0.00	0.00	\$794,160	\$0

Roll Value History

Year	Improvements	Land Market	Ag Valuation	Appraised	HS Cap	Assessed
2019	\$0	\$794,160	0	794,160	\$0	\$794,160
2018	\$0	\$651,020	44,020	44,020	\$0	\$44,020
2017	\$0	\$552,690	43,310	43,310	\$0	\$43,310
2016	\$0	\$462,050	42,960	42,960	\$0	\$42,960
2015	\$0	\$435,880	44,380	44,380	\$0	\$44,380
2014	\$0	\$403,620	41,890	41,890	\$0	\$41,890
2013	\$0	\$403,620	39,410	39,410	\$0	\$39,410
2012	\$0	\$403,620	39,580	39,580	\$0	\$39,580
2011	\$0	\$403,620	39,580	39,580	\$0	\$39,580
2010	\$0	\$373,650	39,760	39,760	\$0	\$39,760
2009	\$0	\$373,650	37,810	37,810	\$0	\$37,810
2008	\$0	\$373,720	36,210	36,210	\$0	\$36,210
2007	\$0	\$325,290	34,970	34,970	\$0	\$34,970
2006	\$0	\$325,290	40,650	40,650	\$0	\$40,650
2005	\$0	\$295,720	40,290	40,290	\$0	\$40,290

Deed History - (Last 3 Deed Transactions)

#	Deed Date	Type	Description	Grantor	Grantee	Volume	Page	Deed Number
1	12/19/2017	WD	WARRANTY DEED	GLENVOIR FARM	J & P LOCKHART BUILDERS LP			2018-000860
2		OT	OTHER - ALL BLANK FIELDS FROM CONVERSION	JANNEY KATIE THOMSON	GLENVOIR FARM	403	671	0

Tax Due

Property Tax Information as of 05/07/2019

Amount Due if Paid on:

Year	Taxing Jurisdiction	Taxable Value	Base Tax	Base Taxes Paid	Base Tax Due	Discount / Penalty & Interest	Attorney Fees	Amount Due
2018	Farm to Market Road	\$44,020	\$0.04	\$0.04	\$0.00	\$0.00	\$0.00	\$0.00
2018	Caldwell County	\$44,020	\$341.24	\$341.24	\$0.00	\$0.00	\$0.00	\$0.00
2018	Lockhart ISD	\$44,020	\$586.51	\$586.51	\$0.00	\$0.00	\$0.00	\$0.00
2018	Plum Creek Underground Water	\$44,020	\$9.42	\$9.42	\$0.00	\$0.00	\$0.00	\$0.00

2018	Plum Creek Conservation District	\$44,020	\$10.21	\$10.21	\$0.00	\$0.00	\$0.00	\$0.00
2018	Caldwell County ESD #2	\$44,020	\$44.02	\$44.02	\$0.00	\$0.00	\$0.00	\$0.00
	2018 TOTAL:		\$991.44	\$991.44	\$0.00	\$0.00	\$0.00	\$0.00
	J & P LOCKHART BUILDERS LP TOTAL:		\$991.44	\$991.44	\$0.00	\$0.00	\$0.00	\$0.00
2017	Plum Creek Underground Water	\$43,310	\$9.27	\$9.27	\$0.00	\$0.00	\$0.00	\$0.00
2017	Farm to Market Road	\$43,310	\$0.04	\$0.04	\$0.00	\$0.00	\$0.00	\$0.00
2017	Caldwell County	\$43,310	\$335.74	\$335.74	\$0.00	\$0.00	\$0.00	\$0.00
2017	Lockhart ISD	\$43,310	\$577.04	\$577.04	\$0.00	\$0.00	\$0.00	\$0.00
2017	Plum Creek Conservation District	\$43,310	\$10.05	\$10.05	\$0.00	\$0.00	\$0.00	\$0.00
2017	Caldwell County ESD #2	\$43,310	\$43.22	\$43.22	\$0.00	\$0.00	\$0.00	\$0.00
	2017 TOTAL:		\$975.36	\$975.36	\$0.00	\$0.00	\$0.00	\$0.00
2016	Caldwell County ESD #2	\$42,960	\$42.96	\$42.96	\$0.00	\$0.00	\$0.00	\$0.00
2016	Farm to Market Road	\$42,960	\$0.04	\$0.04	\$0.00	\$0.00	\$0.00	\$0.00
2016	Caldwell County	\$42,960	\$333.02	\$333.02	\$0.00	\$0.00	\$0.00	\$0.00
2016	Lockhart ISD	\$42,960	\$572.38	\$572.38	\$0.00	\$0.00	\$0.00	\$0.00
2016	Plum Creek Conservation District	\$42,960	\$9.88	\$9.88	\$0.00	\$0.00	\$0.00	\$0.00
2016	Plum Creek Underground Water	\$42,960	\$9.24	\$9.24	\$0.00	\$0.00	\$0.00	\$0.00
	2016 TOTAL:		\$967.52	\$967.52	\$0.00	\$0.00	\$0.00	\$0.00
2015	Caldwell County ESD #2	\$44,380	\$44.38	\$44.38	\$0.00	\$0.00	\$0.00	\$0.00
2015	Farm to Market Road	\$44,380	\$0.04	\$0.04	\$0.00	\$0.00	\$0.00	\$0.00
2015	Caldwell County	\$44,380	\$318.38	\$318.38	\$0.00	\$0.00	\$0.00	\$0.00
2015	Lockhart ISD	\$44,380	\$590.47	\$590.47	\$0.00	\$0.00	\$0.00	\$0.00
2015	Plum Creek Conservation District	\$44,380	\$9.99	\$9.99	\$0.00	\$0.00	\$0.00	\$0.00
2015	Plum Creek Underground Water	\$44,380	\$9.54	\$9.54	\$0.00	\$0.00	\$0.00	\$0.00
	2015 TOTAL:		\$972.80	\$972.80	\$0.00	\$0.00	\$0.00	\$0.00
2014	Lockhart ISD	\$41,890	\$598.65	\$598.65	\$0.00	\$0.00	\$0.00	\$0.00
2014	Plum Creek Underground Water	\$41,890	\$9.22	\$9.22	\$0.00	\$0.00	\$0.00	\$0.00
2014	Plum Creek Conservation District	\$41,890	\$9.22	\$9.22	\$0.00	\$0.00	\$0.00	\$0.00
2014	Farm to Market Road	\$41,890	\$0.04	\$0.04	\$0.00	\$0.00	\$0.00	\$0.00
2014	Caldwell County	\$41,890	\$289.26	\$289.26	\$0.00	\$0.00	\$0.00	\$0.00
2014	Caldwell County ESD #2	\$41,890	\$41.89	\$41.89	\$0.00	\$0.00	\$0.00	\$0.00
	2014 TOTAL:		\$948.28	\$948.28	\$0.00	\$0.00	\$0.00	\$0.00
2013	Lockhart ISD	\$39,410	\$464.84	\$464.84	\$0.00	\$0.00	\$0.00	\$0.00
2013	Plum Creek Underground Water	\$39,410	\$8.67	\$8.67	\$0.00	\$0.00	\$0.00	\$0.00
2013	Plum Creek Conservation District	\$39,410	\$8.67	\$8.67	\$0.00	\$0.00	\$0.00	\$0.00
2013	Farm to Market Road	\$39,410	\$0.04	\$0.04	\$0.00	\$0.00	\$0.00	\$0.00
2013	Caldwell County	\$39,410	\$272.17	\$272.17	\$0.00	\$0.00	\$0.00	\$0.00
2013	Caldwell County ESD #2	\$39,410	\$39.41	\$39.41	\$0.00	\$0.00	\$0.00	\$0.00
	2013 TOTAL:		\$793.80	\$793.80	\$0.00	\$0.00	\$0.00	\$0.00
2012	Plum Creek Underground Water	\$39,580	\$8.31	\$8.31	\$0.00	\$0.00	\$0.00	\$0.00
2012	Lockhart ISD	\$39,580	\$469.73	\$469.73	\$0.00	\$0.00	\$0.00	\$0.00
2012	Plum Creek Conservation District	\$39,580	\$8.31	\$8.31	\$0.00	\$0.00	\$0.00	\$0.00
2012	Farm to Market Road	\$39,580	\$0.04	\$0.04	\$0.00	\$0.00	\$0.00	\$0.00
2012	Caldwell County	\$39,580	\$273.38	\$273.38	\$0.00	\$0.00	\$0.00	\$0.00
2012	Caldwell County ESD #2	\$39,580	\$39.18	\$39.18	\$0.00	\$0.00	\$0.00	\$0.00
	2012 TOTAL:		\$798.95	\$798.95	\$0.00	\$0.00	\$0.00	\$0.00
2011	Plum Creek Underground Water	\$39,580	\$7.92	\$7.92	\$0.00	\$0.00	\$0.00	\$0.00
2011	Lockhart ISD	\$39,580	\$470.29	\$470.29	\$0.00	\$0.00	\$0.00	\$0.00
2011	Plum Creek Conservation District	\$39,580	\$7.92	\$7.92	\$0.00	\$0.00	\$0.00	\$0.00
2011	Farm to Market Road	\$39,580	\$0.04	\$0.04	\$0.00	\$0.00	\$0.00	\$0.00
2011	Caldwell County	\$39,580	\$273.42	\$293.42	\$0.00	\$0.00	\$0.00	\$0.00
2011	Caldwell County ESD #2	\$39,580	\$38.71	\$38.71	\$0.00	\$0.00	\$0.00	\$0.00
	2011 TOTAL:		\$798.30	\$818.30	\$0.00	\$0.00	\$0.00	\$0.00
2010	Lockhart ISD	\$39,760	\$475.05	\$475.05	\$0.00	\$0.00	\$0.00	\$0.00

2010	Plum Creek Underground Water	\$39,760	\$7.75	\$7.75	\$0.00	\$0.00	\$0.00	\$0.00
2010	Plum Creek Conservation District	\$39,760	\$7.75	\$7.75	\$0.00	\$0.00	\$0.00	\$0.00
2010	Farm to Market Road	\$39,760	\$0.04	\$0.04	\$0.00	\$0.00	\$0.00	\$0.00
2010	Caldwell County	\$39,760	\$274.70	\$274.70	\$0.00	\$0.00	\$0.00	\$0.00
2010	Caldwell County ESD #2	\$39,760	\$39.76	\$39.76	\$0.00	\$0.00	\$0.00	\$0.00
	2010 TOTAL:		\$805.05	\$805.05	\$0.00	\$0.00	\$0.00	\$0.00
2009	Lockhart ISD	\$37,810	\$465.06	\$465.06	\$0.00	\$0.00	\$0.00	\$0.00
2009	Plum Creek Underground Water	\$37,810	\$6.99	\$6.99	\$0.00	\$0.00	\$0.00	\$0.00
2009	Plum Creek Conservation District	\$37,810	\$6.99	\$6.99	\$0.00	\$0.00	\$0.00	\$0.00
2009	Farm to Market Road	\$37,810	\$0.08	\$0.08	\$0.00	\$0.00	\$0.00	\$0.00
2009	Caldwell County	\$37,810	\$261.19	\$261.19	\$0.00	\$0.00	\$0.00	\$0.00
	2009 TOTAL:		\$740.31	\$740.31	\$0.00	\$0.00	\$0.00	\$0.00
2008	Lockhart ISD	\$36,210	\$442.66	\$442.66	\$0.00	\$0.00	\$0.00	\$0.00
2008	Plum Creek Underground Water	\$36,210	\$6.52	\$6.52	\$0.00	\$0.00	\$0.00	\$0.00
2008	Plum Creek Conservation District	\$36,210	\$6.52	\$6.52	\$0.00	\$0.00	\$0.00	\$0.00
2008	Farm to Market Road	\$36,210	\$0.11	\$0.11	\$0.00	\$0.00	\$0.00	\$0.00
2008	Caldwell County	\$36,210	\$250.10	\$250.10	\$0.00	\$0.00	\$0.00	\$0.00
	2008 TOTAL:		\$705.91	\$705.91	\$0.00	\$0.00	\$0.00	\$0.00
2007	Farm to Market Road	\$34,970	\$0.14	\$0.14	\$0.00	\$0.00	\$0.00	\$0.00
2007	Caldwell County	\$34,970	\$238.95	\$238.95	\$0.00	\$0.00	\$0.00	\$0.00
2007	Lockhart ISD	\$34,970	\$420.34	\$420.34	\$0.00	\$0.00	\$0.00	\$0.00
2007	Plum Creek Conservation District	\$34,970	\$6.22	\$6.22	\$0.00	\$0.00	\$0.00	\$0.00
2007	Plum Creek Underground Water	\$34,970	\$6.29	\$6.29	\$0.00	\$0.00	\$0.00	\$0.00
	2007 TOTAL:		\$671.94	\$671.94	\$0.00	\$0.00	\$0.00	\$0.00
2006	Farm to Market Road	\$40,650	\$0.20	\$0.20	\$0.00	\$0.00	\$0.00	\$0.00
2006	Caldwell County	\$40,650	\$261.46	\$261.46	\$0.00	\$0.00	\$0.00	\$0.00
2006	Lockhart ISD	\$40,650	\$626.02	\$626.02	\$0.00	\$0.00	\$0.00	\$0.00
2006	Plum Creek Conservation District	\$40,650	\$6.99	\$6.99	\$0.00	\$0.00	\$0.00	\$0.00
2006	Plum Creek Underground Water	\$40,650	\$7.11	\$7.11	\$0.00	\$0.00	\$0.00	\$0.00
	2006 TOTAL:		\$901.78	\$901.78	\$0.00	\$0.00	\$0.00	\$0.00
2005	Lockhart ISD	\$40,290	\$680.90	\$680.90	\$0.00	\$0.00	\$0.00	\$0.00
2005	Plum Creek Underground Water	\$40,290	\$7.61	\$7.61	\$0.00	\$0.00	\$0.00	\$0.00
2005	Plum Creek Conservation District	\$40,290	\$6.93	\$6.93	\$0.00	\$0.00	\$0.00	\$0.00
2005	Farm to Market Road	\$40,290	\$0.24	\$0.24	\$0.00	\$0.00	\$0.00	\$0.00
2005	Caldwell County	\$40,290	\$253.46	\$253.46	\$0.00	\$0.00	\$0.00	\$0.00
	2005 TOTAL:		\$949.14	\$949.14	\$0.00	\$0.00	\$0.00	\$0.00
2004	Lockhart ISD	\$35,320	\$561.13	\$561.13	\$0.00	\$0.00	\$0.00	\$0.00
2004	Plum Creek Underground Water	\$35,320	\$6.68	\$6.68	\$0.00	\$0.00	\$0.00	\$0.00
2004	Plum Creek Conservation District	\$35,320	\$5.83	\$5.83	\$0.00	\$0.00	\$0.00	\$0.00
2004	Farm to Market Road	\$35,320	\$0.25	\$0.25	\$0.00	\$0.00	\$0.00	\$0.00
2004	Caldwell County	\$35,320	\$211.39	\$211.39	\$0.00	\$0.00	\$0.00	\$0.00
	2004 TOTAL:		\$785.28	\$785.28	\$0.00	\$0.00	\$0.00	\$0.00
2003	Farm to Market Road	\$39,230	\$0.31	\$0.31	\$0.00	\$0.00	\$0.00	\$0.00
2003	Caldwell County	\$39,230	\$222.28	\$222.28	\$0.00	\$0.00	\$0.00	\$0.00
2003	Lockhart ISD	\$39,230	\$574.88	\$574.88	\$0.00	\$0.00	\$0.00	\$0.00
2003	Plum Creek Conservation District	\$39,230	\$6.87	\$6.87	\$0.00	\$0.00	\$0.00	\$0.00
2003	Plum Creek Underground Water	\$39,230	\$7.85	\$7.85	\$0.00	\$0.00	\$0.00	\$0.00
	2003 TOTAL:		\$812.19	\$812.19	\$0.00	\$0.00	\$0.00	\$0.00
2002	Plum Creek Conservation District	\$279,390	\$48.89	\$48.89	\$0.00	\$0.00	\$0.00	\$0.00
2002	Lockhart ISD	\$279,390	\$4020.70	\$4020.70	\$0.00	\$0.00	\$0.00	\$0.00
2002	Caldwell County	\$279,390	\$1508.71	\$1508.71	\$0.00	\$0.00	\$0.00	\$0.00
2002	Farm to Market Road	\$279,390	\$2.51	\$2.51	\$0.00	\$0.00	\$0.00	\$0.00
	2002 TOTAL:		\$5580.81	\$5580.81	\$0.00	\$0.00	\$0.00	\$0.00
	GLENVOIR FARM TOTAL:		\$18207.42	\$18227.42	\$0.00	\$0.00	\$0.00	\$0.00

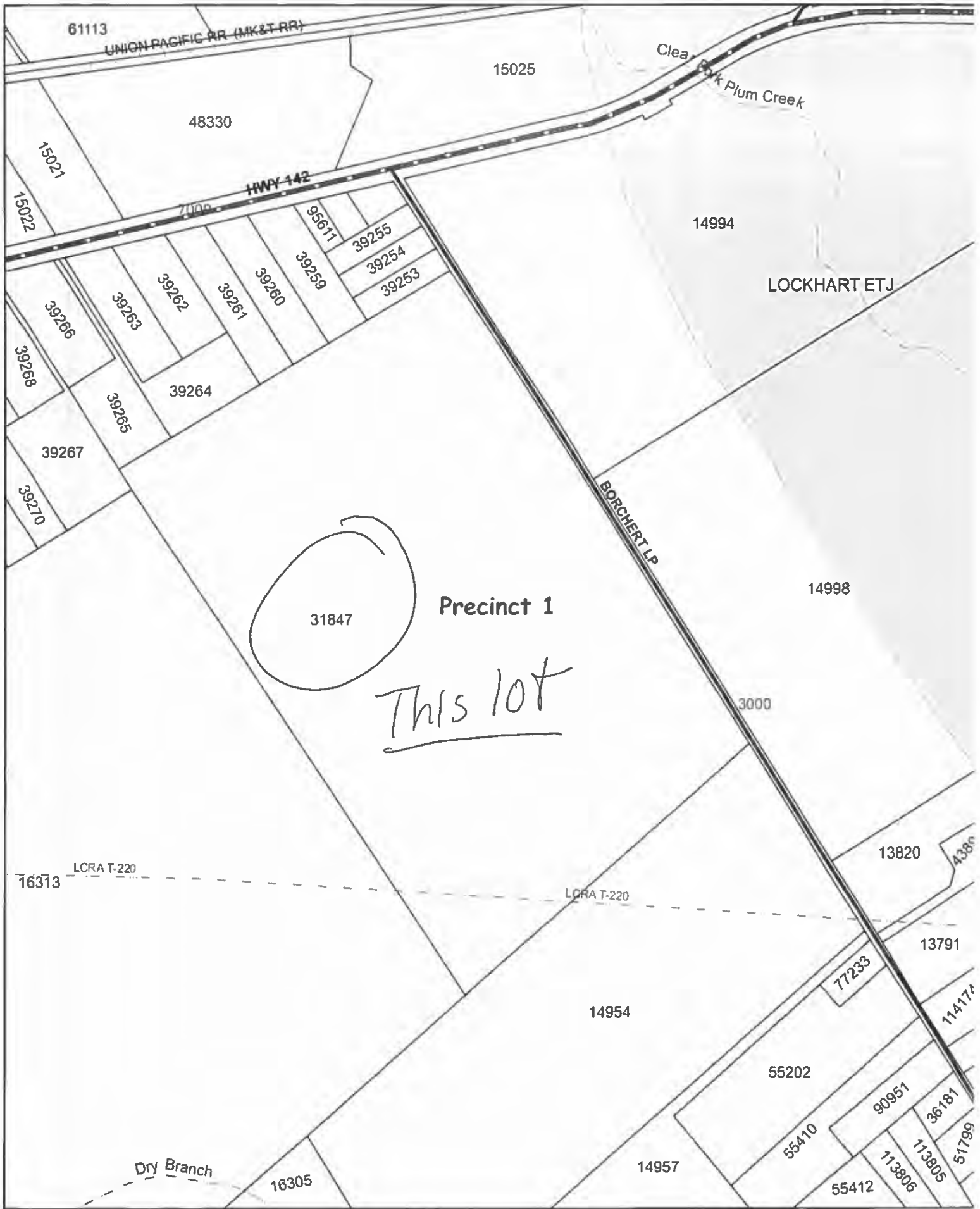

This map is being provided as a courtesy and should only be used as a general guide. It is not a guarantee of location, configuration, size or title. No warranty is expressed or implied to any user for any purpose.

This product is for informational purposes and may not have been prepared for or be suitable for legal, engineering, or surveying purposes. It does not represent an on-the-ground survey and represents only the approximate relative location of property boundaries.

Date Printed
Tuesday, May 07, 2019

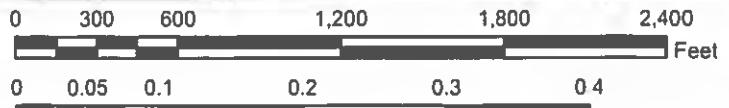

30. Discussion/ Action to consider the approval of the Preliminary Plat for Lytton Hills Subdivision, Phase One to include 75 lots on approximately 458.59 acres located on FM 1854. **Cost: None. Speaker: Commissioner Roland /Kasi Miles. Backup: 44.**

Caldwell County Agenda Item Request Form

To: All Elected Officials and Department Heads – Hand deliver or scan & email to hoppy.haden@co.caldwell.tx.us and ezzy.chan@co.caldwell.tx.us . Deadline is 5:00 pm Tuesday before the Regular meetings, however, please submit this completed form ASAP. "Anything missing will cause the Agenda Item to be held over to the next Regular meeting," according to our Rules & Procedures.

AGENDA DATE: 5/13/19

Type of Agenda Item

- Consent
- Discussion/Action
- Executive Session
- Workshop
- Public Hearing

What will be discussed? What is the proposed motion?
Approval for Preliminary Plat for Lytton Lane

1. Costs:

Actual Cost or Estimated Cost \$⁰ _____

Is this cost included in the County Budget? n/a

Is a Budget Amendment being proposed? n/a

2. Agenda Speakers:

	Name	Representing	Title
(1)	Kasi Miles	Caldwell County	Director of Sanitation
(2)	_____	_____	_____
(3)	_____	_____	_____

3. Backup Materials: None To Be Distributed 44 total # of backup pages (including this page)

Approved by phone:

4. Commissioner Roland
Signature of Court Member

5-7-19
Date

PRELIMINARY PLAT ESTABLISHING LYTTON HILLS PHASE 1

Submitted to the Caldwell County Board of Commissioners by the Caldwell County Board of Commissioners on the 14th day of November, 2018.

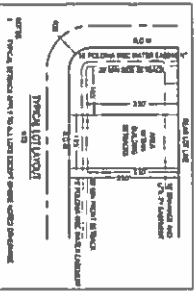
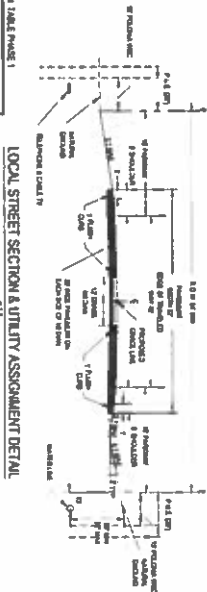
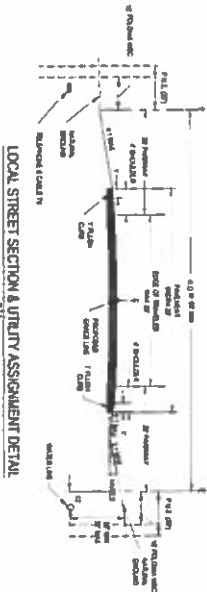

ROAD CLASSIFICATION TABLE PHASE 1	
ROAD NAME	ROAD CLASSIFICATION
OLD STATE STREET	LOCAL STREET
WATER STREET	LOCAL STREET
WINDY STREET	LOCAL STREET
WINDY STREET	LOCAL STREET
WINDY STREET	LOCAL STREET

NOTE: THIS PLAT SHOWS A TYPICAL LOT LAYOUT AT THE INTERSECTION OF OLD STATE STREET AND WINDY STREET. THE ACTUAL LAYOUT OF EACH LOT WILL BE DETERMINED BY THE ENGINEER BASED ON THE SPECIFIC REQUIREMENTS OF EACH LOT AND THE LOCAL STREET SECTION & UTILITY ASSIGNMENT DETAIL.

PROPOSED ROAD DATA	
ROAD NAME	ROAD CLASSIFICATION
OLD STATE STREET	LOCAL STREET
WATER STREET	LOCAL STREET
WINDY STREET	LOCAL STREET
WINDY STREET	LOCAL STREET
WINDY STREET	LOCAL STREET

PROPOSED ROAD DATA	
ROAD NAME	ROAD CLASSIFICATION
OLD STATE STREET	LOCAL STREET
WATER STREET	LOCAL STREET
WINDY STREET	LOCAL STREET
WINDY STREET	LOCAL STREET
WINDY STREET	LOCAL STREET

DATE: NOVEMBER 15, 2018
SHEET 3 OF 42



MATCHLINE (SEE SHEET 5)

MATCHLINE (SEE SHEET 7)

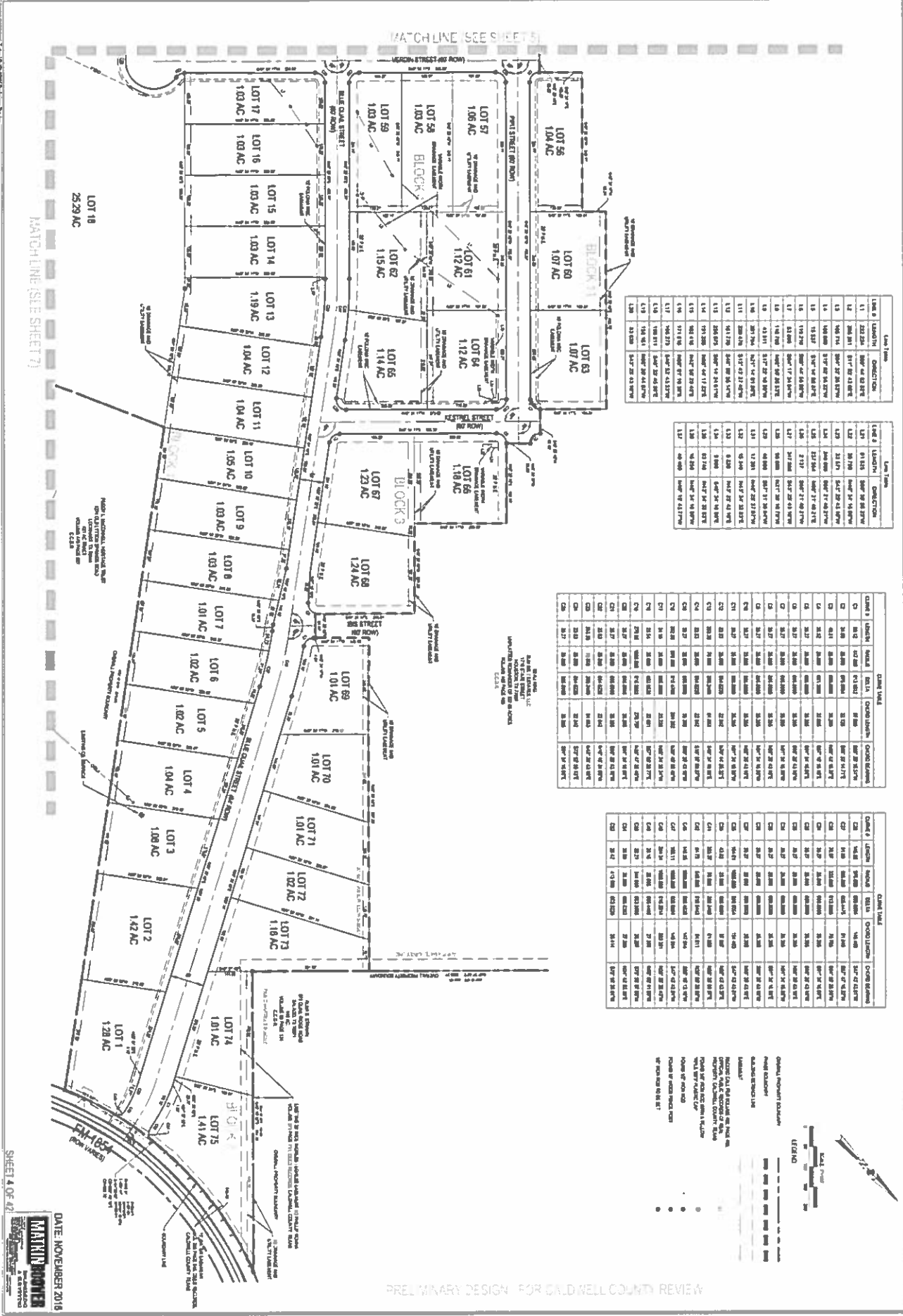

Block 1	Lot No.	Area	Notes
Block 1	LOT 57	1.08 AC	Subdivided and Platted Under
	LOT 58	1.03 AC	Subdivided and Platted Under
	LOT 59	1.03 AC	Subdivided and Platted Under
	LOT 60	1.07 AC	Subdivided and Platted Under
	LOT 61	1.12 AC	Subdivided and Platted Under
	LOT 62	1.19 AC	Subdivided and Platted Under
Block 2	LOT 63	1.07 AC	Subdivided and Platted Under
	LOT 64	1.12 AC	Subdivided and Platted Under
	LOT 65	1.14 AC	Subdivided and Platted Under
Block 3	LOT 66	1.18 AC	Subdivided and Platted Under
	LOT 67	1.23 AC	Subdivided and Platted Under
	LOT 68	1.24 AC	Subdivided and Platted Under

Block 4	Lot No.	Area	Notes
Block 4	LOT 1	1.03 AC	Subdivided and Platted Under
	LOT 2	1.03 AC	Subdivided and Platted Under
	LOT 3	1.03 AC	Subdivided and Platted Under
	LOT 4	1.03 AC	Subdivided and Platted Under
	LOT 5	1.03 AC	Subdivided and Platted Under
	LOT 6	1.03 AC	Subdivided and Platted Under
	LOT 7	1.03 AC	Subdivided and Platted Under
	LOT 8	1.03 AC	Subdivided and Platted Under
	LOT 9	1.03 AC	Subdivided and Platted Under
	LOT 10	1.03 AC	Subdivided and Platted Under
	LOT 11	1.04 AC	Subdivided and Platted Under
	LOT 12	1.04 AC	Subdivided and Platted Under
	LOT 13	1.19 AC	Subdivided and Platted Under
	LOT 14	1.03 AC	Subdivided and Platted Under
	LOT 15	1.03 AC	Subdivided and Platted Under
	LOT 16	1.03 AC	Subdivided and Platted Under
	LOT 17	1.03 AC	Subdivided and Platted Under

Block 5	Lot No.	Area	Notes
Block 5	LOT 18	2.29 AC	Subdivided and Platted Under
	LOT 19	1.03 AC	Subdivided and Platted Under
	LOT 20	1.03 AC	Subdivided and Platted Under
	LOT 21	1.03 AC	Subdivided and Platted Under
	LOT 22	1.03 AC	Subdivided and Platted Under
	LOT 23	1.03 AC	Subdivided and Platted Under
	LOT 24	1.03 AC	Subdivided and Platted Under
	LOT 25	1.03 AC	Subdivided and Platted Under
	LOT 26	1.03 AC	Subdivided and Platted Under
	LOT 27	1.03 AC	Subdivided and Platted Under
	LOT 28	1.03 AC	Subdivided and Platted Under
	LOT 29	1.03 AC	Subdivided and Platted Under
	LOT 30	1.03 AC	Subdivided and Platted Under
	LOT 31	1.03 AC	Subdivided and Platted Under
	LOT 32	1.03 AC	Subdivided and Platted Under
	LOT 33	1.03 AC	Subdivided and Platted Under

Block 6	Lot No.	Area	Notes
Block 6	LOT 34	1.03 AC	Subdivided and Platted Under
	LOT 35	1.03 AC	Subdivided and Platted Under
	LOT 36	1.03 AC	Subdivided and Platted Under
	LOT 37	1.03 AC	Subdivided and Platted Under
	LOT 38	1.03 AC	Subdivided and Platted Under
	LOT 39	1.03 AC	Subdivided and Platted Under
	LOT 40	1.03 AC	Subdivided and Platted Under
	LOT 41	1.03 AC	Subdivided and Platted Under
	LOT 42	1.03 AC	Subdivided and Platted Under
	LOT 43	1.03 AC	Subdivided and Platted Under
	LOT 44	1.03 AC	Subdivided and Platted Under
	LOT 45	1.03 AC	Subdivided and Platted Under
	LOT 46	1.03 AC	Subdivided and Platted Under
	LOT 47	1.03 AC	Subdivided and Platted Under
	LOT 48	1.03 AC	Subdivided and Platted Under
	LOT 49	1.03 AC	Subdivided and Platted Under

DATE: NOVEMBER 2016
MANFORD PROPPER
 ENGINEERS & ARCHITECTS
 1111 W. 10TH ST. SUITE 100
 OKLAHOMA CITY, OK 73106
 PHONE: (405) 233-8888
 FAX: (405) 233-8889
 WWW.MANFORDPROPPER.COM

DATE: NOVEMBER 2016
 SHEET 5 OF 4

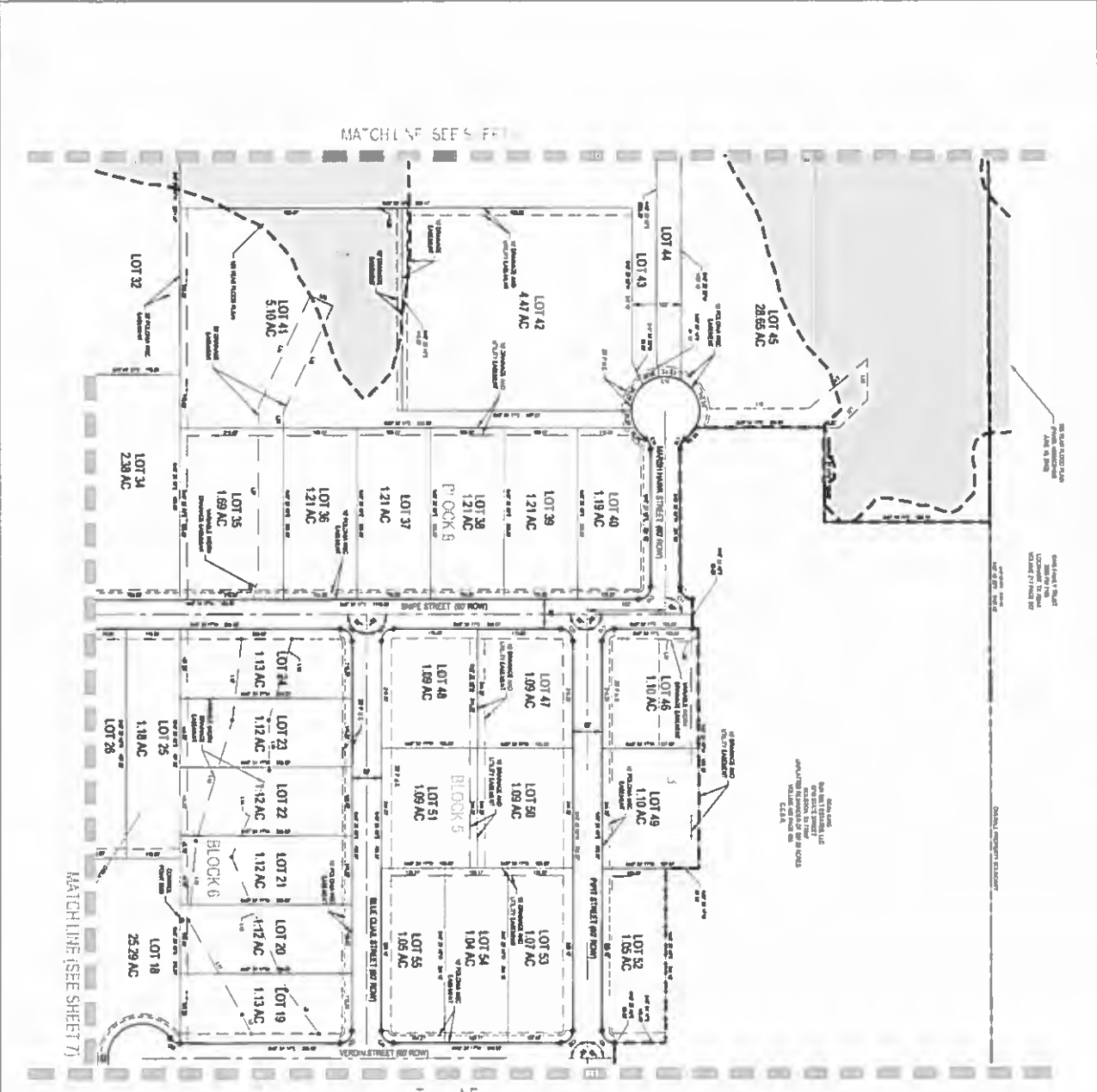

NO.	DESCRIPTION	DATE	BY	REVISION
1	PRELIMINARY	11/15/16	MM	
2	REVISED	11/15/16	MM	
3	REVISED	11/15/16	MM	
4	REVISED	11/15/16	MM	
5	REVISED	11/15/16	MM	
6	REVISED	11/15/16	MM	
7	REVISED	11/15/16	MM	
8	REVISED	11/15/16	MM	
9	REVISED	11/15/16	MM	
10	REVISED	11/15/16	MM	
11	REVISED	11/15/16	MM	
12	REVISED	11/15/16	MM	
13	REVISED	11/15/16	MM	
14	REVISED	11/15/16	MM	
15	REVISED	11/15/16	MM	
16	REVISED	11/15/16	MM	
17	REVISED	11/15/16	MM	
18	REVISED	11/15/16	MM	
19	REVISED	11/15/16	MM	
20	REVISED	11/15/16	MM	
21	REVISED	11/15/16	MM	
22	REVISED	11/15/16	MM	
23	REVISED	11/15/16	MM	
24	REVISED	11/15/16	MM	
25	REVISED	11/15/16	MM	
26	REVISED	11/15/16	MM	
27	REVISED	11/15/16	MM	
28	REVISED	11/15/16	MM	
29	REVISED	11/15/16	MM	
30	REVISED	11/15/16	MM	
31	REVISED	11/15/16	MM	
32	REVISED	11/15/16	MM	
33	REVISED	11/15/16	MM	
34	REVISED	11/15/16	MM	
35	REVISED	11/15/16	MM	
36	REVISED	11/15/16	MM	
37	REVISED	11/15/16	MM	
38	REVISED	11/15/16	MM	
39	REVISED	11/15/16	MM	
40	REVISED	11/15/16	MM	
41	REVISED	11/15/16	MM	
42	REVISED	11/15/16	MM	
43	REVISED	11/15/16	MM	
44	REVISED	11/15/16	MM	
45	REVISED	11/15/16	MM	
46	REVISED	11/15/16	MM	
47	REVISED	11/15/16	MM	
48	REVISED	11/15/16	MM	
49	REVISED	11/15/16	MM	
50	REVISED	11/15/16	MM	
51	REVISED	11/15/16	MM	
52	REVISED	11/15/16	MM	
53	REVISED	11/15/16	MM	
54	REVISED	11/15/16	MM	
55	REVISED	11/15/16	MM	
56	REVISED	11/15/16	MM	
57	REVISED	11/15/16	MM	
58	REVISED	11/15/16	MM	
59	REVISED	11/15/16	MM	
60	REVISED	11/15/16	MM	
61	REVISED	11/15/16	MM	
62	REVISED	11/15/16	MM	
63	REVISED	11/15/16	MM	
64	REVISED	11/15/16	MM	
65	REVISED	11/15/16	MM	
66	REVISED	11/15/16	MM	
67	REVISED	11/15/16	MM	
68	REVISED	11/15/16	MM	
69	REVISED	11/15/16	MM	
70	REVISED	11/15/16	MM	
71	REVISED	11/15/16	MM	
72	REVISED	11/15/16	MM	
73	REVISED	11/15/16	MM	
74	REVISED	11/15/16	MM	
75	REVISED	11/15/16	MM	
76	REVISED	11/15/16	MM	
77	REVISED	11/15/16	MM	
78	REVISED	11/15/16	MM	
79	REVISED	11/15/16	MM	
80	REVISED	11/15/16	MM	
81	REVISED	11/15/16	MM	
82	REVISED	11/15/16	MM	
83	REVISED	11/15/16	MM	
84	REVISED	11/15/16	MM	
85	REVISED	11/15/16	MM	
86	REVISED	11/15/16	MM	
87	REVISED	11/15/16	MM	
88	REVISED	11/15/16	MM	
89	REVISED	11/15/16	MM	
90	REVISED	11/15/16	MM	
91	REVISED	11/15/16	MM	
92	REVISED	11/15/16	MM	
93	REVISED	11/15/16	MM	
94	REVISED	11/15/16	MM	
95	REVISED	11/15/16	MM	
96	REVISED	11/15/16	MM	
97	REVISED	11/15/16	MM	
98	REVISED	11/15/16	MM	
99	REVISED	11/15/16	MM	
100	REVISED	11/15/16	MM	



DATE: NOVEMBER 2016
 SHEET 5 OF 4

DATE: NOVEMBER 2016
 SHEET 5 OF 4

DATE: NOVEMBER 2016
 SHEET 5 OF 4

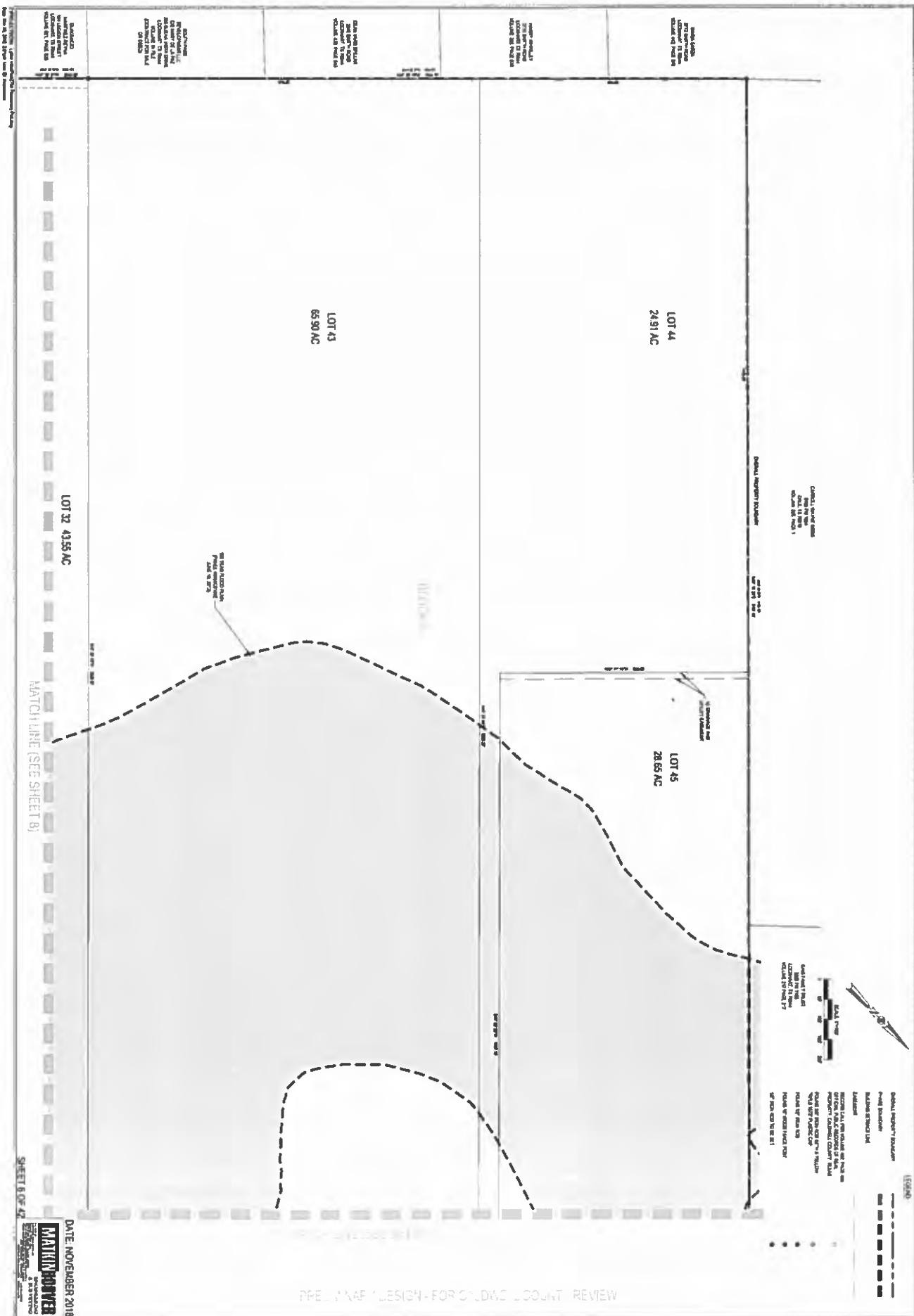

DEVELOPER'S EASEMENT
FOR THE PURPOSES OF
CONVEYING THE RIGHT OF
WAY TO THE ADJACENT
PROPERTY

DEVELOPER'S EASEMENT
FOR THE PURPOSES OF
CONVEYING THE RIGHT OF
WAY TO THE ADJACENT
PROPERTY

DEVELOPER'S EASEMENT
FOR THE PURPOSES OF
CONVEYING THE RIGHT OF
WAY TO THE ADJACENT
PROPERTY

DEVELOPER'S EASEMENT
FOR THE PURPOSES OF
CONVEYING THE RIGHT OF
WAY TO THE ADJACENT
PROPERTY

DEVELOPER'S EASEMENT
FOR THE PURPOSES OF
CONVEYING THE RIGHT OF
WAY TO THE ADJACENT
PROPERTY

DEVELOPER'S EASEMENT
FOR THE PURPOSES OF
CONVEYING THE RIGHT OF
WAY TO THE ADJACENT
PROPERTY

DEVELOPER'S EASEMENT
FOR THE PURPOSES OF
CONVEYING THE RIGHT OF
WAY TO THE ADJACENT
PROPERTY

DEVELOPER'S EASEMENT
FOR THE PURPOSES OF
CONVEYING THE RIGHT OF
WAY TO THE ADJACENT
PROPERTY

DEVELOPER'S EASEMENT
FOR THE PURPOSES OF
CONVEYING THE RIGHT OF
WAY TO THE ADJACENT
PROPERTY

DEVELOPER'S EASEMENT
FOR THE PURPOSES OF
CONVEYING THE RIGHT OF
WAY TO THE ADJACENT
PROPERTY

DEVELOPER'S EASEMENT
FOR THE PURPOSES OF
CONVEYING THE RIGHT OF
WAY TO THE ADJACENT
PROPERTY

DEVELOPER'S EASEMENT
FOR THE PURPOSES OF
CONVEYING THE RIGHT OF
WAY TO THE ADJACENT
PROPERTY

DEVELOPER'S EASEMENT
FOR THE PURPOSES OF
CONVEYING THE RIGHT OF
WAY TO THE ADJACENT
PROPERTY

DEVELOPER'S EASEMENT
FOR THE PURPOSES OF
CONVEYING THE RIGHT OF
WAY TO THE ADJACENT
PROPERTY

DEVELOPER'S EASEMENT
FOR THE PURPOSES OF
CONVEYING THE RIGHT OF
WAY TO THE ADJACENT
PROPERTY

DEVELOPER'S EASEMENT
FOR THE PURPOSES OF
CONVEYING THE RIGHT OF
WAY TO THE ADJACENT
PROPERTY

DEVELOPER'S EASEMENT
FOR THE PURPOSES OF
CONVEYING THE RIGHT OF
WAY TO THE ADJACENT
PROPERTY

DEVELOPER'S EASEMENT
FOR THE PURPOSES OF
CONVEYING THE RIGHT OF
WAY TO THE ADJACENT
PROPERTY

DEVELOPER'S EASEMENT
FOR THE PURPOSES OF
CONVEYING THE RIGHT OF
WAY TO THE ADJACENT
PROPERTY

DEVELOPER'S EASEMENT
FOR THE PURPOSES OF
CONVEYING THE RIGHT OF
WAY TO THE ADJACENT
PROPERTY

DEVELOPER'S EASEMENT
FOR THE PURPOSES OF
CONVEYING THE RIGHT OF
WAY TO THE ADJACENT
PROPERTY

DEVELOPER'S EASEMENT
FOR THE PURPOSES OF
CONVEYING THE RIGHT OF
WAY TO THE ADJACENT
PROPERTY

DEVELOPER'S EASEMENT
FOR THE PURPOSES OF
CONVEYING THE RIGHT OF
WAY TO THE ADJACENT
PROPERTY

DEVELOPER'S EASEMENT
FOR THE PURPOSES OF
CONVEYING THE RIGHT OF
WAY TO THE ADJACENT
PROPERTY

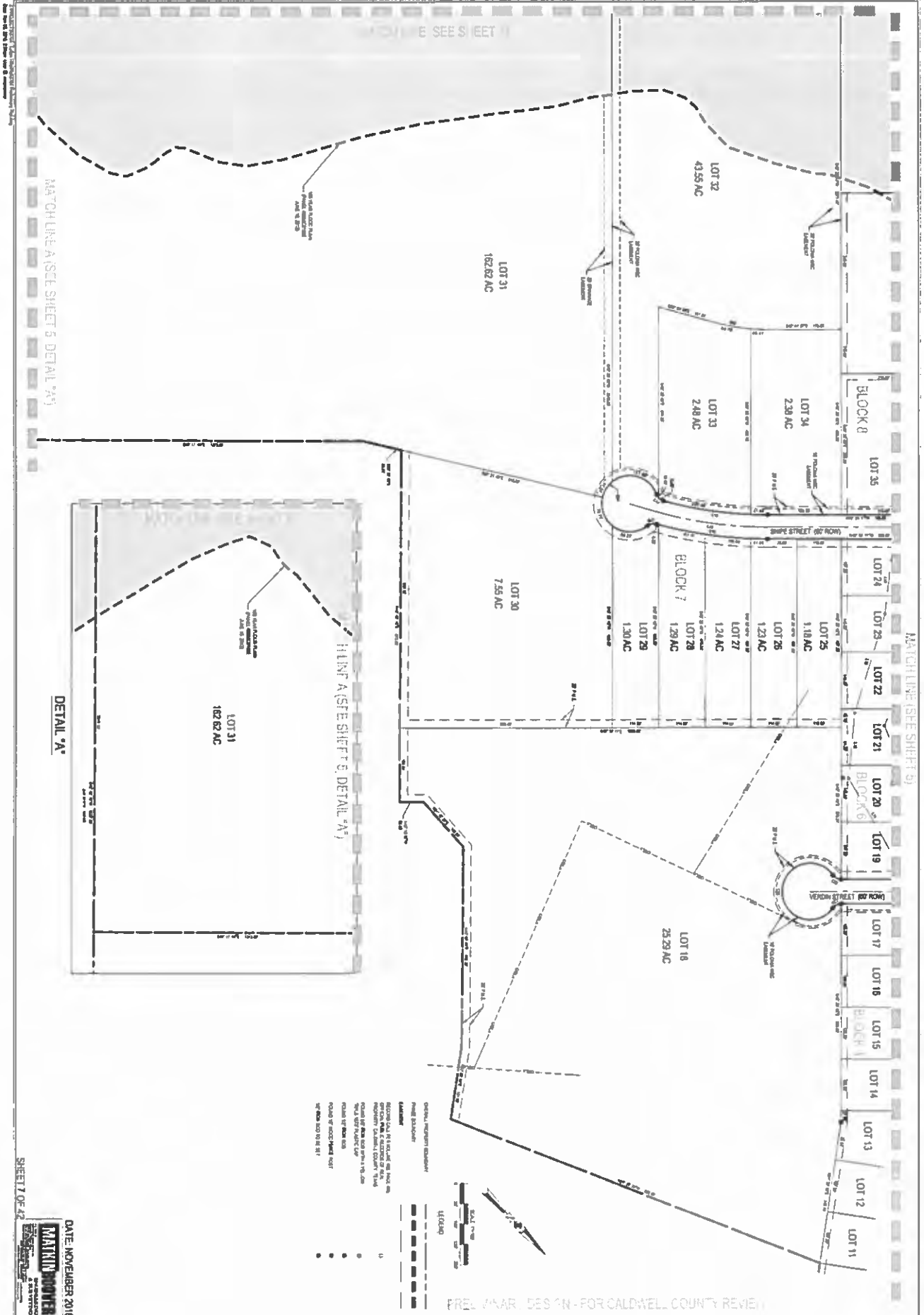

MATCHLINE (SEE SHEET 6 DETAIL 'A')

MATCHLINE (SEE SHEET 9)

MATCHLINE (SEE SHEET 8, DETAIL 'A')

DETAIL 'A'

DATE NOVEMBER 2016
MARTIN PROWSE
 ENGINEER
 1111 S. 10TH ST. SUITE 100
 OKLAHOMA CITY, OK 73106
 PHONE: 405.233.1111
 FAX: 405.233.1112
 WWW.MARTINPROWSE.COM

SHEET 17 OF 42

PRELIMINARY DESIGN - FOR CALDWELL COUNTY REVIEW

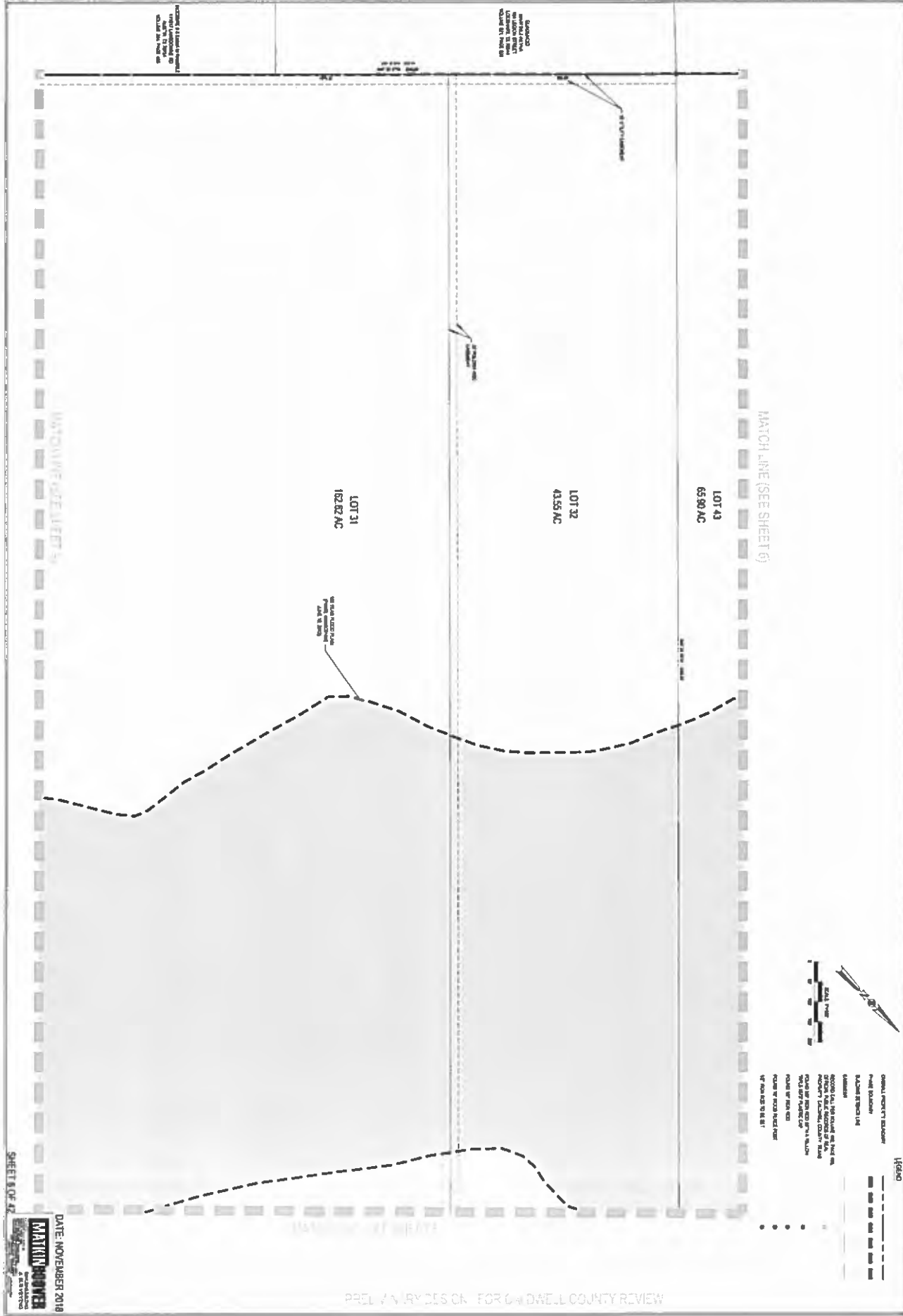

DATE: NOVEMBER 2018

MATTHEW BOWEN

PRELIMINARY DESIGN FOR G-4 DWELL COUNTY REVIEW

LEGEND

LEGEND

- SUBDIVISION
- EXISTING BOUNDARY
- PROPOSED BOUNDARY
- PROPOSED EASEMENT
- PROPOSED RIGHT-OF-WAY
- PROPOSED ROAD
- PROPOSED CANAL
- PROPOSED DRAINAGE
- PROPOSED UTILITY
- PROPOSED FENCE
- PROPOSED SIGN
- PROPOSED LIGHT
- PROPOSED SIGN
- PROPOSED LIGHT

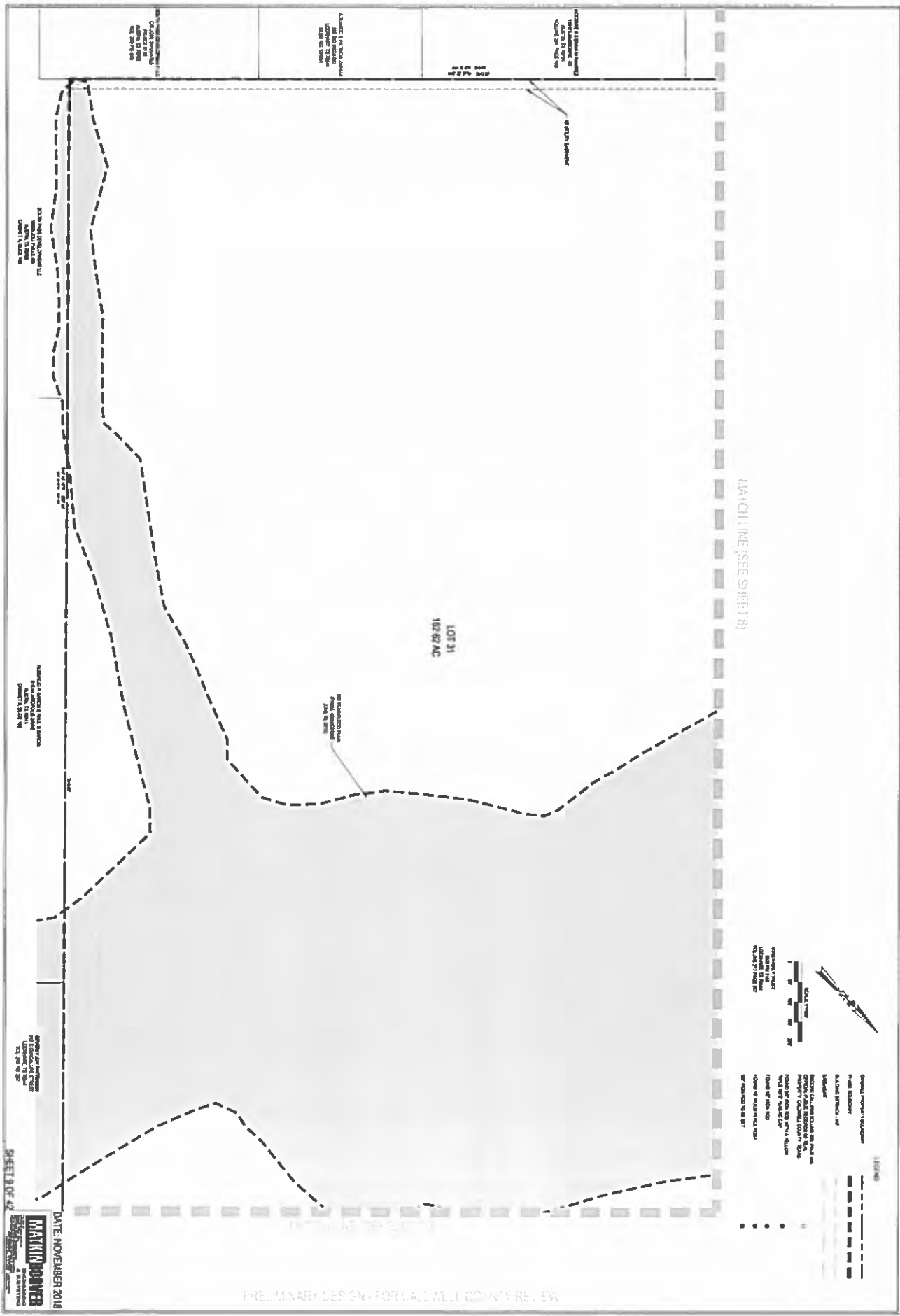

DATE: NOVEMBER 2018
MATTIN MOORE
 SURVEYOR
 10000 100TH AVENUE
 SUITE 100
 FORT COLLINS, CO 80526
 (970) 223-1111

April 8, 2019

Kasi Miles
Caldwell County
1700 FM 2720
Lockhart, TX 78644

RE: Lytton Hills, Phase 1 - Preliminary Plat
BCG Project No. 070004-22-002

Ms. Miles,

Bowman Consulting Group has completed our review of the April 4, 2019 revision to the Preliminary Plat for Lytton Hills Phase 1 subdivision. The subdivision consists of 75 lots on 458.59 ac. with a minimum lot size of 1.01 ac. and takes access from FM 1854. As we discussed and required, the Applicant has added a note to the plat stating that "The final plat and construction plans for this subdivision will not be accepted for review by Caldwell County until the TxDOT driveway permit for the street connection to FM 1854 is approved".

The Preliminary Plat appears to be in general conformance with the rules and regulations of Caldwell County. Therefore, we recommend placing the Preliminary Plat on the Commissioners Court agenda for consideration.

It is our pleasure to be of assistance to the County on this project. If the Court would like for me to be present at Commissioners Court when the preliminary plat is considered, please let me know by the preceding Friday morning.

Please let us know if you have any questions in regards to these comments.

Sincerely,



Charles R. Wirtanen, P.E.
Bowman Consulting

cc: Farris Abboushi

March 29, 2019

Kasi Miles
Caldwell County
1700 FM 2720
Lockhart, TX 78644

RE: **Lytton Hills, Phase 1 – Preliminary Plat**
BCG Project No. 070004-22-002

Ms. Miles,

Bowman Consulting Group has completed our review of the application and revisions for the Lytton Hills, Phase 1 – Preliminary Plat. The subdivision consists of 75 lots on 458.59 ac. with a minimum lot size of 1.01 ac. and takes access from FM 1854. The subdivision is located in the Jonathan Burleson Survey, Abstract No. 34; the Isaac Allen Survey, Abstract No. 28; and the Pablo Martinez Survey, Abstract No. 181 all in Caldwell County, TX.

The Applicant has addressed all outstanding technical comments with the exception of providing evidence of TxDOT driveway approval. The Preliminary Plat appears to be in general conformance with the rules and regulations of Caldwell County. Therefore, we recommend placing the Preliminary Plat on the Commissioners Court agenda for approval if a note is added to the Preliminary Plat that states **“the Final Plat and Construction Plans for this subdivision will not accepted for review by Caldwell County until the TXDOT driveway permit for the street connection to FM 1854 is approved”**.

It is our pleasure to be of assistance to the County on this project. If the Court would like for me to be present at Commissioners Court when the preliminary plat is considered, please let me know by the preceding Friday morning.

Please let us know if you have any questions in regards to these comments.

Sincerely,



Charles R. Wirtanen, P.E.
Bowman Consulting

cc: Farris Abboushi

RE: 2704.00 Lytton Hills TxDOT Driveway Permit

Faris Abboushi <fabboushi@bowmanconsulting.com>

Tue 2/19/2019 2:46 PM

To: 'Kasi Miles' <miles479@hotmail.com>

Cc: Charles Wirtanen <cwirtanen@bowmanconsulting.com>

Kasi,

Bowman's 4th Technical Review letter stated that "The Applicant has addressed all outstanding technical comments with the exception of providing evidence of TxDOT driveway approval". Given that they have not provided a complete TxDOT approval, the County *could* hold off on approving the Preliminary Plat at this time.

However, I talked to Mark and confirmed that they're only asking to get the Preliminary Plat approved at this time (no construction approval or Final Plat approval), so that they can move forward with the submittal of the Final Plat and Construction Documents for review.

Given that, I think we can recommend approval as long as they add a note on the Preliminary Plat indicating that the Final Plat shall not be recorded until the TxDOT Donation Agreement have been finalized and Driveway Permit has been obtained.

Thanks,

Faris

Faris Abboushi | Bowman Consulting

direct: 512.672.8977 | mobile: 512.771.4448

TBPE Firm No. F-14309

From: Mark Ramsower <mramsower@matkinhoover.com>

Sent: Tuesday, February 19, 2019 1:53 PM

To: 'Kasi Miles' <miles479@hotmail.com>; Charles Wirtanen <cwirtanen@bowmanconsulting.com>; Josh Valenta <jvalenta@matkinhoover.com>; Faris Abboushi <fabboushi@bowmanconsulting.com>

Cc: Joe Cohan <jcohan@matkinhoover.com>; 'William Semora Jr., P.E. (William.Semora@txdot.gov)'

<William.Semora@txdot.gov>; Ivan Baker <Ivan.Baker@txdot.gov>; Beau King [REDACTED]

Subject: RE: 2704.00 Lytton Hills TxDOT Driveway Permit

Kasi,

I received an email from Willie on 2/6/2019 saying his team started the Land Donation process. That being said, I believe they still need some documents for the extended ROW portion of the Land Donation, including a survey appraisal of the property, title commitment, and sealed land description with Texas set monuments. At this stage we have given the sealed field notes and exhibits needed for Beau King to purchase the property that is being donated to TxDOT. Mr. King is also working on the appraisal and we have our survey scheduled to set the monuments and create the land description.

We have been told the Land Donation process will take several months to complete, and we would like to get the plat approved so we can move forward during that time. During our meetings, TxDOT agreed to grant preliminary approval while the Land Donation Agreement is being processed.

August 30, 2017

Kasi Miles
Caldwell County
1700 FM 2720
Lockhart, TX 78644

RE: Lytton Hills, Phase 1 – Preliminary Plat – 1st Technical Review
BCG Project No. 070004-44-002

Ms. Miles,

Bowman Consulting Group has completed our 1st technical review of the application for the Lytton Hills, Phase 1 – Preliminary Plat, and we have found the following deficiencies:

PRELIMINARY PLAT (PP)

1. Revise the PP to address any relevant changes that result from the PEP & ESR comment section. *[Caldwell County Development Ordinance (CCDO), Section 3.4.1.A; 3.4.1.B; 3.4.1.C]*
2. Show and update the date of submittal on the plat. *[3.4.1.2]*
3. Provide the missing street name between Lots 68 and 69.
4. Blue Quail Street, between Lot 7 and FM 1854, meets the criteria for Minor Collector Street. Pavement design shall reflect that classification. Revise the table on Sheet 3 of 41. *Appendix, Table B-2.*
5. Provide a second roadway connection to FM 1854; or, meet the requirements for not having a secondary access *[A.1.E; A.1.F]*.

PRELIMINARY ENGINEERING PLAN (PEP), ENGINEERING SUMMARY REPORT (ESR)

1. Provide a typical section for Blue Quail Street from Lot 7 to FM 1854.
2. Revise the entry road to meet secondary access requirement for 2- 20 ft. lane with median. Explain how Lots 1-6 and 69- 75 will achieve access across the 12 ft. median. *[Appendix A.A.1.F]*
3. Obtain preliminary OSSF approvals by Caldwell County Sanitation Department. *[3.4.1.C.5; A.2.E; A.2.F]*
4. Add missing topographic datum and data sources to maps on the Drainage Area Map. *[3.4.1.B.1]*
5. Provide a typical section for Blue Quail Street between Lot 7 and FM 1854. Provide a pavement section detail indicating the section will comply with the local collector pavement section design as shown in the Final Geotechnical Report. *Appendix B,B.8,A.*
6. Revise the Pavement Section Detail on sheet 34 of the Preliminary Construction plans to indicate the section will comply with the local street pavement section design as shown in the Final Geotechnical Report. *Appendix B,B.8,A.*

7. Delete or revise the Pavement Section Detail on sheet 35 of the Preliminary Construction plans.
8. Provide a street name and street signage plan for the subdivision. *Appendix B,B.7.*
9. Obtain the approval of TxDOT for the intersection of Blue Quail Street with FM 1854. *Appendix B,B.2.V.*
10. Obtain preliminary OSSF approvals. *[3.4.1.C.5; A.2.E; A.2.F]*
11. For Detention Waiver, provide a separate written request with justification. Include a statement that the development will result in less than 15% impervious cover and will utilize open swale drainage. *[E.1.E.3]*
12. Provide approved water plans with the Final Plat. *[3.4.1.B.3; 3.6.3.A]*

Please let us know if you have any questions in regards to these comments.

Sincerely,



Charles R. Wirtanen, P.E.
Bowman Consulting

January 23, 2018

Kasi Miles
Caldwell County
1700 FM 2720
Lockhart, TX 78644

RE: Lytton Hills, Phase 1 – Preliminary Plat – 2nd Technical Review
BCG Project No. 070004-22-002

Ms. Miles,

Bowman Consulting Group has completed our 2nd technical review of the application and revisions for the Lytton Hills, Phase 1 – Preliminary Plat, and we have the following comments:

PRELIMINARY PLAT (PP)

We have completed our review of the Preliminary Plan and found that the proposed plan meets the required criteria contained in the Caldwell County Development Code (CCDO)

PRELIMINARY ENGINEERING PLAN (PEP), ENGINEERING SUMMARY REPORT (ESR)

1. Provide a letter of approval from TXDOT for the proposed location and general configuration of the proposed intersection of Blue Quail and FM 1854. We are concerned that left turn movements out of and into the subdivision, significantly exceed 90°. See the attached plan sheet.
2. The stop signs on Blue Quail, other than at FM 1854 shown on the signage plan should be deleted.

Please let us know if you have any questions in regards to these comments.

Sincerely,



Charles R. Wirtanen, P.E.
Bowman Consulting

cc: Jacque Thomas

September 13, 2018

Kasi Miles
Caldwell County
1700 FM 2720
Lockhart, TX 78644

RE: Lytton Hills, Phase 1 – Preliminary Plat – 3rd Technical Review
BCG Project No. 070004-22-002

Ms. Miles,

Bowman Consulting Group has completed our 3rd technical review of the application and revisions for the Lytton Hills, Phase 1 – Preliminary Plat, and we have the following comments:

PRELIMINARY PLAT (PP)

We have completed our review of the Preliminary Plat and found that the proposed plan, with the exceptions noted below, meets the required criteria contained in the Caldwell County Development Code (CCDO).

PRELIMINARY ENGINEERING PLAN (PEP), ENGINEERING SUMMARY REPORT (ESR)

1. Please provide a Preliminary Plat showing any changes caused by the following comments.
2. Reduce the sheet flow length on drainage calculations to 150 ft. for the drainage report. Flows for ditch and culvert calculations will be reviewed with the construction plans (the sheet flow length should be reduced on those calculations also). See 630.1502b Velocity Method) Part 630 Chapter 15 of the Hydrology of the National Engineering Handbook for documentation. Assuming the resulting flows are similar to the original submittal, detention will be waived for the project.
3. The stop signs on Blue Quail, other than at FM 1854 shown on the signage plan (Sht. CT101 of the Preliminary Construction Plans) should be deleted.
4. Provide drainage information for the south end of Snipe Rd. Where does flow go after leaving cul-de-sac (easement needed)?
5. Call out the easement across lots 19-24 as a “drainage easement” on the Preliminary Plat.

Ms. Kasi Miles

September 13, 2018

6. Please provide information on the treatment of the 12 ft. median shown between EOP-EOP on the plans. The section in Sht. Sht. CG501 of the Preliminary Construction Plans implies it is paved. Please verify the surface treatment of the median.
7. The 4 ft. shoulders shown on Sht. CG501 of the Preliminary Construction Plans on the local street should be paved and the Phase Development agreement exhibit.
8. Please provide drainage easements on the Preliminary Plat to accommodate significant encroachments by drainage infrastructure. If the encroachment is several lots in a row, widen the right-of-way.
9. Please note that the Phasing Agreement requires a Preliminary Plat for the entire tract.
10. Please furnish documentation indicating TXDOT approval.

Please let us know if you have any questions in regards to these comments.

Sincerely,



Charles R. Wirtanen, P.E.
Bowman Consulting

cc: Jacque Thomas
Tracy Bratton

7258

MOBILE HOME DEVELOPMENT CORP

1718 STATE STREET
HOUSTON TX 77007
(713) 681-0070

AMEGY BANK, NATIONAL ASSOCIATION
HOUSTON TX 77057
33-1125-1130

6/8/2017

PAY TO THE ORDER OF CALDWELL COUNTY

\$ **5 750 00

Five Thousand Seven Hundred Fifty and 00/100***** DOLLARS

PROTECTED AGAINST FRAUD

CALDWELL COUNTY
1700 FM 2720
LOCKHART, TX 78644

MEMO Recording Plat - Lytton Hills



CALDWELL COUNTY SANITATION DEPT.
405 E. MARKET ST.
LOCKHART, TEXAS 78644
(512) 398-1803

6055

DATE 6-26-17

RECEIVED FROM Mobile Home Development \$ 5,750.00
Five thousand seven hundred fifty dollars
FOR Pre plat - Lytton Hills

AMOUNT OF ACCOUNT	
THIS PAYMENT	5,750.00
BALANCE DUE	0

- CASH
- CHECK
- CREDIT CARD
- MONEY ORDER

BY *Thank You*
Kasi L. Miles

Details... Bank Intuitive CheckLock™ Secure Check

November 6, 2018



Bowman Consulting
Attn: Charles Wirtanen, P.E.
1120 South Capital of Texas Hwy, Bldg 3, Ste 220
Austin, Texas 78746

Re: Lytton Hills, Phase 1 – Preliminary Plat
Matkin Hoover Job No. 2704.00

Dear Mr. Wirtanen:

This letter and its attachments serve as a response to comments received on September 13, 2018 concerning the above referenced subdivision.

Comment 1: Please provide a Preliminary Plat showing any changes caused by the following comments.
Response: Concur, see comments below.
Comment 2: Reduce the sheet flow length on drainage calculations to 150 ft. for the drainage report. Flows for ditch and culvert calculations will be reviewed with the construction plans (the sheet flow length should be reduced on those calculations also). See 630.1502b Velocity Method) Part 630 Chapter 15 of the Hydrology of the National Engineering Handbook for documentation. Assuming the resulting flows are similar to the original submittal, detention will be waived for the project.
Response: Concur, sheet flow lengths were reduced from 300 ft to 150 ft for all drainage calculations. Similar results were obtained, however some channels needed to be widened due to increased flows. See the street and drain plan & profile sheets (15 – 33) and the attached drainage report.
Comment 3: The stop signs on Blue Quail, other than at FM 1854 shown on the signage plan (Sht. CT101 of the Preliminary Construction Plans) should be deleted.
Response: Concur, stop signs have been removed from Blue Quail street, along with changes to the other streets as well. See Phase 1 Street Name and Signage Plan (sheet 34).
Comment 4: Provide drainage information for the south end of Snipe Rd. Where does flow go after leaving cul-de-sac (easement needed)?
Response: Concur, a channel and easement have been added to the end of Snipe street. See sheet 20.



Comment 5:

Call out the easement across lots 19-24 as a “drainage easement” on the Preliminary Plat.

Response: Concur, “Variable Width Drainage Easement” label has been added to sheet 4 and 5 of the Preliminary Plat.

Comment 6:

Please provide information on the treatment of the 12 ft. median shown between EOP-EOP on the plans. The section in Sht. Sht. CG501 of the Preliminary Construction Plans implies it is paved. Please verify the surface treatment of the median.

Response: Concur, the 12 ft median shown on sheets 15 and 16 is grass. The detail has been updated to eliminate confusion, see sheet CG501.

Comment 7:

The 4 ft. shoulders shown on Sht. CG501 of the Preliminary Construction Plans on the local street should be paved and the Phase Development agreement exhibit.

Response: Concur, the pavement section detail has been updated for clarification. See sheets 10 and 35.

Comment 8:

Please provide drainage easements on the Preliminary Plat to accommodate significant encroachments by drainage infrastructure. If the encroachment is several lots in a row, widen the right-of-way.

Response: Concur, drainage easements have been added at grading encroachments near lots 35, 46, 64, and 66. See sheets 4 and 5 of the Preliminary Plat.

Comment 9:

Please note that the Phase Agreement requires a Preliminary Plat for the entire tract.

Response: Per phone discussion with Charles Wirtanen, a preliminary plat for Phase 2 is not needed if certain items are made clear on the Phase Agreement. The Phase Agreement includes a Phase Exhibit showing the proposed layout for Phase 2. This serves as the Preliminary Plan for the entire tract as stated in section 2.03 of the Phasing Agreement. To clarify, the large 54.40 and 25.82 acre tracts (# 108 and 109) will not be subdivided further, giving the total lot count at 34 as shown. No new roads will be added, and the land use (single family residential) has been added to the Phase 2 Summary Table on the Phase Exhibit.

Comment 10:

Please furnish documentation indicating TxDOT approval.

Response: Concur, TxDOT plans for a left turn lane have been submitted and are currently under review. Any documentation from TxDOT stating preliminary approval will be provided as soon as we receive it. TxDOT has stated they require a donation agreement before final approval, and they are willing to approve a temporary construction entrance for work to begin before final approval is issued.



Should you or your staff have questions, comments, or require additional information, please feel free to contact our office.

Sincerely,
Matkin Hoover Engineering & Surveying
TBPE Firm Registration No. F-4512

Joshua Valenta, P.E.
Vice President

Attachments: Phasing Agreement
Engineering Summary Report
Detention Waiver
Construction Plans
Preliminary Plat
Drainage Report

RE: 2704.00 Lytton Hills TxDOT Driveway Permit

William Semora Jr <William.Semora@txdot.gov>

Thu 2/7/2019 6:11 PM

To: Mark Ramsower <mramsower@matkinhoover.com>; Kasi L. Miles (miles479@hotmail.com) <miles479@hotmail.com>
Cc: Josh Valenta <jvalenta@matkinhoover.com>; Joe Cohan <jcohan@matkinhoover.com>; Ivan Baker <Ivan.Baker@txdot.gov>; Beau King <beausking@gmail.com>

📎 1 attachments (1 MB)

30 GRADING LAYOUT.pdf;

Mark,

Based off our discussions regarding the attached preliminary layout, TxDOT has approved allowing access for the Lytton Hills subdivision on FM 1854. This approval is preliminary and is hinged upon Lytton Hills entering into a donation agreement for new ROW and construction of the attached upgrades to FM 1854. Until the final permit is approved, Lytton Hills may be issued a temporary construction permit to begin work on their property. TxDOT will do so at your request. If you have any further questions or concerns, please feel free to give me a call.

Thanks
Willie



Texas Department of Transportation

William L. Semora Jr., P.E. | Asst. Area Engineer
Bastrop Area Office
174 State Highway 21 East Bastrop Texas. 78602
Phone: (512)308-4486 | Email: William.Semora@txdot.gov

From: Mark Ramsower [mailto:mramsower@matkinhoover.com]

Sent: Tuesday, February 5, 2019 2:18 PM

To: William Semora Jr

Cc: Josh Valenta; Joe Cohan; Ivan Baker; Beau King

Subject: 2704.00 Lytton Hills TxDOT Driveway Permit

This email originated from outside of the organization. Do not click links or open attachments unless you recognize the sender and know the content is safe.

Willie,

In the meeting this morning you mentioned being willing to give approval to county for the driveway permit so we can move forward with the preliminary plat. I spoke with Charles Wirtanen with Bowman Consulting and he said they would need the TxDOT 1058 Permit Form (attached) to approve the prelim plat, is this correct?

Thanks,

Mark Ramsower, E.I.T.

MATKINHOOVER

DATE: 10/15/15
 DRAWN BY: J. CALDWELL
 CHECKED BY: J. CALDWELL
 PROJECT NO.: 15-001



NOTES:

1. ALL DIMENSIONS ARE IN FEET UNLESS OTHERWISE NOTED.
2. THE CENTERLINE OF THE ROAD IS SHOWN BY A DASHED LINE.
3. THE PROPOSED GRADE IS SHOWN BY A SOLID LINE.
4. THE EXISTING GRADE IS SHOWN BY A DOTTED LINE.
5. THE PROPOSED DRIVE AND DRIVEWAY DETAIL IS SHOWN IN THE INSET.
6. THE PROPOSED DRIVE AND DRIVEWAY DETAIL IS TO BE CONSTRUCTION OF A DRIVE AND DRIVEWAY DETAIL.
7. THE PROPOSED DRIVE AND DRIVEWAY DETAIL IS TO BE CONSTRUCTION OF A DRIVE AND DRIVEWAY DETAIL.
8. THE PROPOSED DRIVE AND DRIVEWAY DETAIL IS TO BE CONSTRUCTION OF A DRIVE AND DRIVEWAY DETAIL.
9. THE PROPOSED DRIVE AND DRIVEWAY DETAIL IS TO BE CONSTRUCTION OF A DRIVE AND DRIVEWAY DETAIL.
10. THE PROPOSED DRIVE AND DRIVEWAY DETAIL IS TO BE CONSTRUCTION OF A DRIVE AND DRIVEWAY DETAIL.

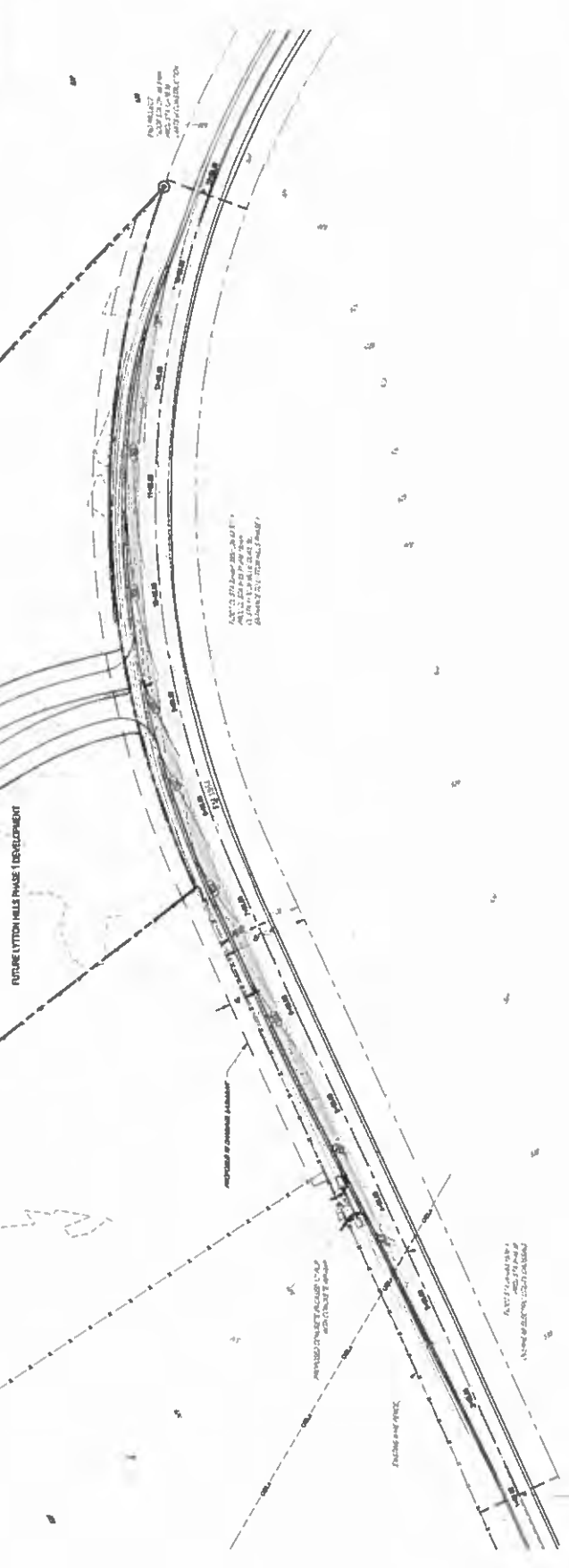

**F.M. 1854 TURN LANE
 GRADING LAYOUT**

DATE: 10/15/15	TITLE: F.M. 1854 TURN LANE GRADING LAYOUT	SCALE: AS SHOWN
DRAWN BY: J. CALDWELL	CHECKED BY: J. CALDWELL	PROJECT NO.: 15-001
DATE: 10/15/15	SCALE: AS SHOWN	PROJECT NO.: 15-001

MATKINHOVER
 ENGINEERING
 & SURVEYING

10000 WEST 10TH STREET
 SUITE 100
 FORT WORTH, TEXAS 76132
 PHONE: (817) 335-1111
 FAX: (817) 335-1112
 WWW.MATKINHOVER.COM



DATE: 10/15/15
 DRAWN BY: J. CALDWELL
 CHECKED BY: J. CALDWELL
 PROJECT NO.: 15-001



August 4, 2015

Matkin Hoover Engineering
1718 State Street
Houston, TX 77007

RE: **Installation of Overhead Electric Distribution Facilities for
Lytton Hills Subdivision Project.**

Dear Mr. Valenta,

We have received your inquiry regarding electric service for the proposed **Lytton Hills Subdivision Project** located in Caldwell County and have determined that is in the certificated service territory of Bluebonnet Electric Cooperative, Inc. and we are therefore willing to provide electric service. Bluebonnet's promise to provide service is contingent upon the applicant fulfilling all the requirements of our Tariff including our Line Extension Policy. We look forward to working with you to provide the electric service this project requires. We need the following items satisfied before we can proceed with our design and cost estimate:

1. One set of blueline plans and a CAD (AutoCAD format) file for all construction activity on the entire project.
2. An exclusive assignment (agreeable to us) for our facilities in either a 30' overhead or a 20' underground dedicated Bluebonnet Electric Cooperative Easement or a Public Utility Easement.
3. Your proposed construction schedule for all phases of this project.
4. A Development Information Request Form for all facilities to be served in all phases of this project and/or a detailed electrical load analysis for all commercial facilities to be served in all phases of this project.

Please see the attached Bluebonnet Timeline Sheet for your project/job work progress and scheduling.

Bluebonnet Electric Cooperative shall at all times have complete ownership and control of any facilities we install and reserve the right to serve other customers from these facilities at any time.

Should you have any questions or need additional information, please give me a call at 888-622-2583, ext. 8527

Sincerely,

Rodney Gerik
Sr. Project Coordinator

NEPTUNE - WILKINSON ASSOCIATES, INC.
Consulting Engineers
TBPE Firm# F-359

4010 Manchaca Road
Austin, Texas 78704

(512) 462-3373
(FAX) 462-3469

April 17, 2014

Paul Pittman, Manager
Polonia Water Supply Corporation
P.O. Box 778
Lockhart, Texas 78644

Re: Sun Belt Estates, LLC (Beau King) Water Service
75 Acreage Tracts on a 328 Acre Tract Fronting F.M. 1854
(Between Dale and Lytton Springs)
NWA# 1062-101

Dear Paul:

A Non-Standard Water Service Application for the referenced proposed development was received April 3, 2014 with a sketch showing a concept layout for service to 75 tracts. My understanding of the location of the property to be served is marked on the attached drawing.

The property is not located within Polonia Water Supply Corporation's (Polonia WSC) certificated service area. This area of the distribution system is served by gravity flow from the Lytton Springs 250,000 Gallon Elevated Tank with hydraulic elevation of 738 feet and this pressure zone is capable of meeting the Texas Commission on Environmental Quality (TCEQ) minimum criteria for 75 service connections at the subdivision location.

Under Polonia WSC's Subdivision Service Extension Policy, it is the responsibility of the developer of the subdivision to construct all water lines and appurtenances required to serve the subdivision and necessary to provide water to individual tracts.

Water service to the 75 single-family residential tracts can be committed when the following conditions have been met.

1. It is recommended the developer provide to Polonia WSC either a written determination by the Caldwell County Engineer that the proposed subdivision is exempt from Caldwell County subdivision platting regulations as set forth in Section 3.3.1 of Caldwell County Development Ordinance or a preliminary plat approved by Caldwell County.

2. The Polonia WSC's Certificated Service Area must be amended to include this subdivision area. The cost to amend the Polonia WSCs' CCN water service area is estimated to be \$5,000.00.
3. Prior to beginning construction, the developer shall enter into a Non-Standard Service Agreement prepared by Polonia WSC agreeing to pay all project cost required to serve the 75 tracts. The final cost for construction is the cost submitted by a qualified contractor acceptable to Polonia WSC and the cost for preparing engineering documents for construction. The final cost for construction shall be the actual cost for construction incurred by Polonia WSC.
3. All of the following conditions should be included in the Non-Standard Service Agreement for the 75 tracts to receive water service:
 - a. Polonia WSC's commitment to supply water to the 75 tracts is subject to the Rules and Regulations Concerning Service which are contained in the Tariff and Subdivision Service Extension Policy. After purchasing a tract, the owner of the lot must pay to Polonia WSC all applicable fees required for water service to have a meter set including the Membership Fee (currently \$100.00) and the Service Connection Fee (currently \$850.00).
 - b. Water service is limited to one meter per tract, serving one single-family dwelling unit, e.g. service will not be provided to multiple dwelling units on any tract within this development.
 - c. Water service will not be provided to tract(s) created by resubdivision of any tract not shown on the record Final Plat or the surveyor's plat.
 - d. Payment for the Capital Improvement Fee (CIF), currently \$1,850.00 per service connection (75 connections at \$1,850.00 equals \$138,750.00), must be remitted to Polonia WSC at time the Non-Standard Service Agreement is signed by the developer, i.e. fee must be paid up-front and is non-refundable and non-transferable.
 - e. The Capital Improvement Fee (CIF) payment will reserve water service to the 75 tracts provided the monthly Reserve Service charge (50 percent of the base monthly charge which is currently \$18.95) for each tract is paid. Presently, the total monthly Reserve Service charge is \$710.63 for the 75 tracts.

Payment of the monthly Reserve Service charge shall begin with the first monthly billing cycle after signing of Non-Standard Service Agreement relative to this inquiry. This monthly Reserve Service charge is subject to change if the base monthly charge is changed in Polonia WSC's Tariff. The water service commitment is limited to the number of tracts for which the monthly Reserve Service charge is paid.

4. Conditions a, b and c stated above must also be clearly stated on the recordation Final Plat or surveyor's plat.
5. All construction work associated with the subdivision water distribution system shall be in accordance with TCEQ regulations relating to public water distribution system, Polonia WSC Tariff, Subdivision Service Extension Policy and Construction Standards. All cost associated with constructing lines required to serve the tracts shall be paid by the Developer.
6. Polonia WSC construction standards include but are not limited to the following:
 - a. Pipe for distribution lines is to be PVC C900 DR 18 and laid at a depth to provide minimum 30 inch cover.
 - b. Provide gate valve on each radiating line at line intersections.
 - c. Provide fire hydrant locations so that the structure on each lot is within 1,000 feet of a fire hydrant.
 - d. All service lines are to be Class 200 polyethylene.
 - e. Plans for all construction work must be submitted to the Polonia WSC for review and approval and a preconstruction meeting is required prior to any work being undertaken.
 - f. Descriptive materials must be submitted for review and approval for all items to be included in construction.
 - g. The utility contractor and any subcontractor(s) must provide certificate of insurance meeting the requirements of Polonia WSC prior to the preconstruction meeting.

8. The highest ground elevation in the proposed subdivision is approximately 560 feet and the lowest elevation is about 495 feet. The hydraulic elevation of the 225,000 gallon Lytton Springs Elevated Tank is 738 feet. The static pressure range will be about 77 psi at the highest elevation and about 105 psi at the lowest elevation off the remote elevated tank. This pressure requires an individual pressure regulating valve (PRV) at each service connection be provided.

The probable cost for construction of facilities to serve the proposed subdivision is provided in Table 1 and is based upon a sketch developed in our office from the development concept provided for this response. The opinion of cost is intended for planning and project feasibility considerations only. If there are any questions, give me a call.

Sincerely,



Joel D. Wilkinson, P.E.

Enclosures
JDW:jm

**TABLE 1
OPINION OF PROBABLE COST
FOR
75 ACREAGE TRACTS DEVELOPMENT BETWEEN DALE AND LYTTON SPRINGS
POLONIA WATER SUPPLY CORPORATION
April 11, 2014**

<u>Item No.</u>	<u>Description</u>	<u>Quantity</u>	<u>Unit</u>	<u>Unit Price</u>	<u>Total</u>
1	Mobilization	1	LS	\$ 12,000.00	\$ 12,000.00
2	8" PVC, C-900, DR-18 Pipe	820	LF	28.00	22,960.00
2	6" PVC, C-900, DR-18 Pipe	12,060	LF	20.00	241,200.00
3	8" Wet Connection	1	EA	1,000.00	1,000.00
4	8" Gate Valve, M.J.	3	EA	1,500.00	4,500.00
5	6" Gate Valve, M.J.	5	EA	1,000.00	5,000.00
6	8" Tee, D.I., M.J.	1	EA	800.00	800.00
7	8" x 6" Tee, D.I., M.J.	1	EA	700.00	700.00
8	8" x 6" Reducer, D.I., M.J.	1	EA	500.00	500.00
9	6" 90 Degree Bend, D.I. M.J.	5	EA	400.00	2,000.00
10	Fire Hydrant	8	EA	3,850.00	30,800.00
11	Service Connection (excluding meter and PRV)	75	EA	400.00	30,000.00
12	1 ½" Polyethylene Service Tubing	1,080	LF	5.00	5,400.00
13	4" PVC SDR-21 Tubing Sleeve	900	LF	12.00	10,800.00
14	1" Air/Vacuum Relief Valve	1	EA	1,800.00	<u>1,800.00</u>
TOTAL PROBABLE CONSTRUCTION COST					\$ 369,460.00

NOTES

- 1 This Opinion of Cost is based upon typical cost of rural subdivision work. It is not based upon prepared plans or on-site inspection of pipeline route. Actual cost will be the final cost of the work performed by a qualified utility contractor after completion and acceptance of construction by PWSC.
- 2 Opinion of Cost does not include any environmental clearances required for subdivision.
- 3 Easements for water line route will be dedicated to PWSC on approved Final Plat.
- 4 Cost is based upon all work being contracted for construction by PWSC.
- 5 Tabulated cost does not include preparation of engineering plans, specifications and contract documents.

Prepared for Polonia Water Supply Corporation



Joel D. Wilkinson 04/11/2014
 Joel D. Wilkinson, P.E.
 Neptune-Wilkinson Associates, Inc. TBPE Firm#F-359

NWA #1062-101

June 19, 2017

Caldwell County
1700 FM 2720
Lockhart, Texas 78644

Re: Lytton Hills Preliminary Plat
Engineering Summary Report

To Whom It May Concern:

The intent of this summary is to provide a brief description of proposed design for the subdivision of Lytton Hills in Caldwell County as well as prove requirements set forth within the Caldwell County Development Ordinance were met.

Proposed Drainage Systems

Proposed drainage for the development will closely follow existing conditions of the site. Pre- and post-developed conditions were compared at 5 different computation points which are described with further detail in the drainage report provided.

FEMA Flood Insurance Study

A portion of the property is located in the 100 year floodplain according to FEMA Firm No. 48055C0150E dated June 19, 2012, however no study is required due to all development being located outside of the flood zone. Storm water runoff increase from the development will also be mitigated, preventing any increase in water surface elevations. Attached to this report is Figure 8.0 – FEMA Exhibit showing the location of the floodplain in the proposed development.

Groundwater Districts

After researching groundwater conservation districts in the Caldwell county area, it was determined that the proposed development does not fall within any conservation district boundaries. Attached to this engineering summary report is an exhibit (Figure 9.0 – Groundwater Exhibit) showing the development's location with respect to nearby groundwater conservation districts.

Proposed Utilities

For this development, on-site sewage facilities and domestic water services are to be used. On-site sewage facilities, conforming to requirements in the Caldwell County Development ordinance, will be utilized to treat the proposed development's wastewater. Polonia Water Supply Corporation intends to provide the subdivision with domestic water and attached is their certified letter of serviceability. Electric will be supplied to the development through Bluebonnet Electric Cooperative whose letter of serviceability is attached to this report as well.

Proposed Streets

The streets for the development will be county owned streets. No dues from property owners will be collected for the maintenance and upkeep of these streets.

If you have any questions or require additional information please feel free to contact me.

Sincerely,
Matkin Hoover Engineering & Surveying
TBPE Firm Registration No. F-4512

Joshua J. Valenta, P.E.
Project Manager

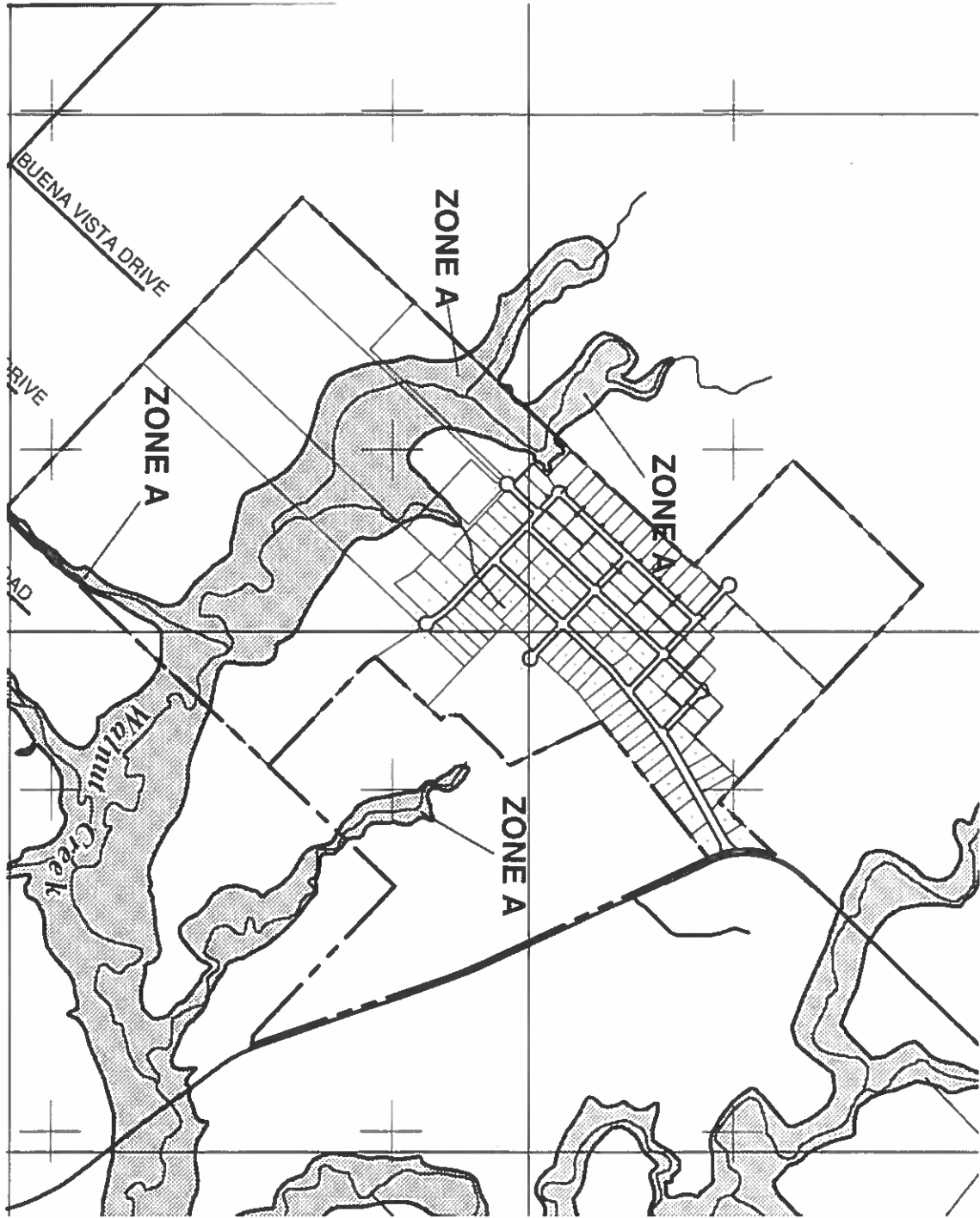

 <p>FEMA FEDERAL EMERGENCY MANAGEMENT AGENCY CALDWELL COUNTY, TEXAS MAP AND OPERATIONAL PLAN</p>	<p>LEGEND</p> <ul style="list-style-type: none"> Zone A: Flood Hazard Area Zone B: Flood Hazard Area Zone C: Flood Hazard Area Zone D: Flood Hazard Area Zone E: Flood Hazard Area Zone F: Flood Hazard Area Zone G: Flood Hazard Area Zone H: Flood Hazard Area Zone I: Flood Hazard Area Zone J: Flood Hazard Area Zone K: Flood Hazard Area Zone L: Flood Hazard Area Zone M: Flood Hazard Area Zone N: Flood Hazard Area Zone O: Flood Hazard Area Zone P: Flood Hazard Area Zone Q: Flood Hazard Area Zone R: Flood Hazard Area Zone S: Flood Hazard Area Zone T: Flood Hazard Area Zone U: Flood Hazard Area Zone V: Flood Hazard Area Zone W: Flood Hazard Area Zone X: Flood Hazard Area Zone Y: Flood Hazard Area Zone Z: Flood Hazard Area
-----------------------------------------------------------------------------------------------------------------------------------------------------------------------------------------------------------------------------------	-------------------------------------------------------------------------------------------------------------------------------------------------------------------------------------------------------------------------------------------------------------------------------------------------------------------------------------------------------------------------------------------------------------------------------------------------------------------------------------------------------------------------------------------------------------------------------------------------------------------------------------------------------------------------------------------------------------------------------------------------------------------------------------------------------------------------------------------------------------------------------------------------------------------------------------------------------------------------------------------------------------

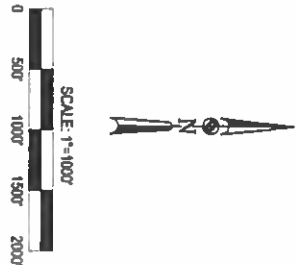

JOB NO. 2704.00
 DATE JUN 2017
 DESIGNED CLM
 CHECKED JLV
 SHEET FIG. 8.0

FEMA EXHIBIT
 FOR
 LYTON HILLS
 CALDWELL COUNTY, TEXAS

MATKINHOOPER
 ENGINEERING & SURVEYING

P.O. BOX 94
 SPRINGER ROAD SUITE 100
 BIRMINGHAM, TEXAS 75768
 PHONE: 817.595.8800 FAX: 817.595.8800
 TEXAS REGISTERED ENGINEERING FIRM # 08411

CIVIL ENGINEERS SURVEYORS LAND PLANNERS CONSTRUCTION MANAGERS CONSULTANTS

Z:\PROJECTS\2014 - Lyton Hills\Exhibit\Figure 9.0 - Groundwater Exhibiting
 Date: Jun 06, 2017 7:41am User ID: manower

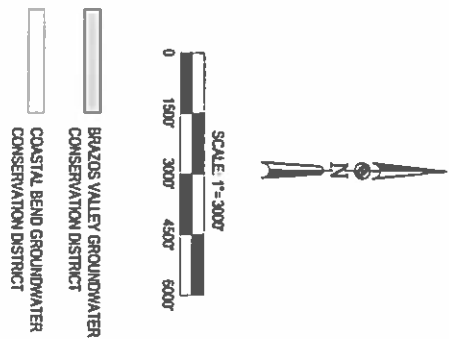
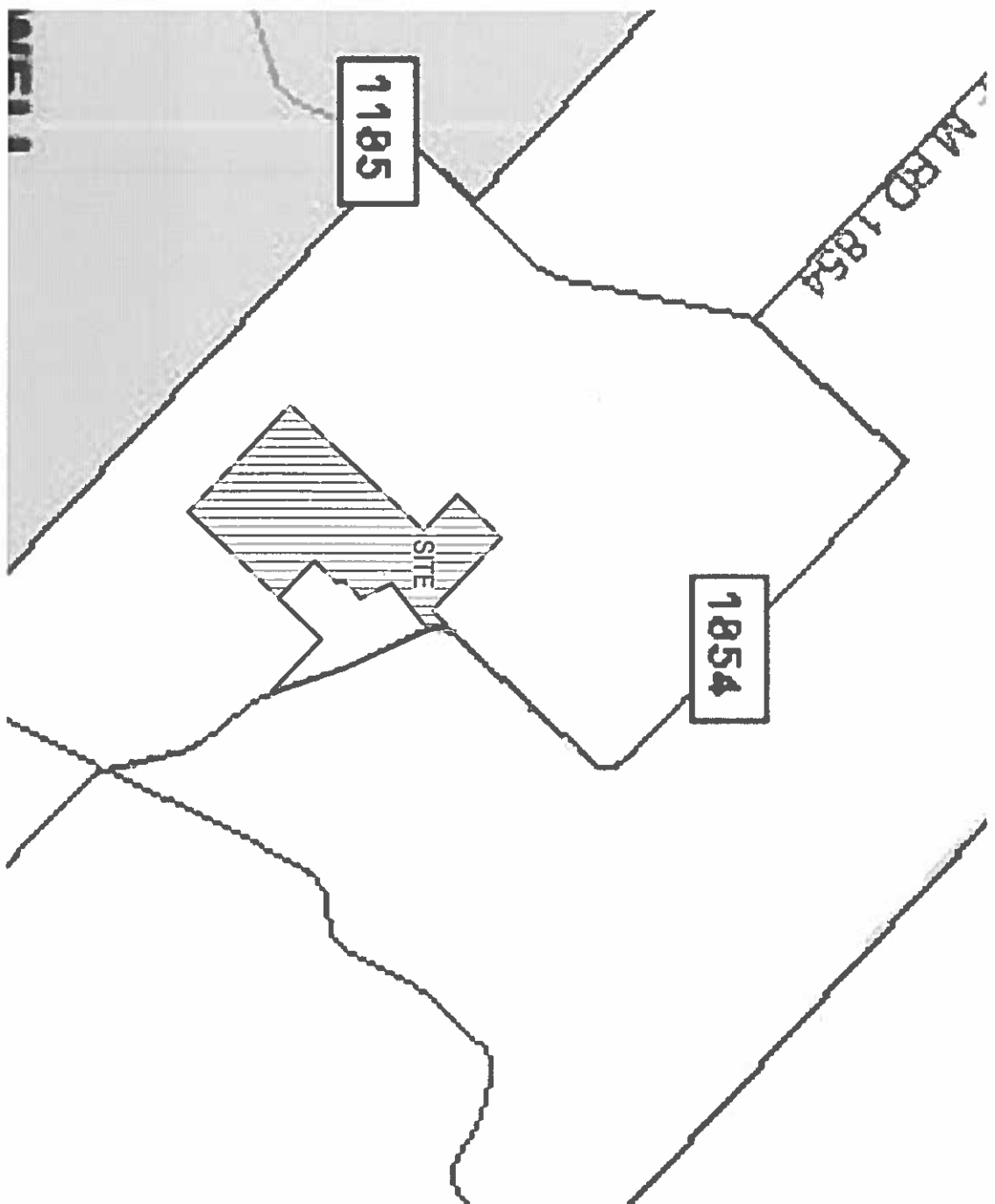

JOB NO. 2704.00
 DATE JUN 2017
 DESIGNED CLM
 CHECKED JLV
 SHEET FIG. 9.0

GROUNDWATER EXHIBIT
 FOR
 LYTON HILLS
 CALDWELL COUNTY, TEXAS

MATKINHOOPER
 ENGINEERING & SURVEYING

P.O. BOX 54
 8000 W. ROAD BLVD. 148
 BOONVILLE, TEXAS 77820
 OFFICE: 817-336-8888 FAX: 817-336-8899
 TEXAS REGISTERED ENGINEERING FIRM # 04411

CIVIL ENGINEERS SURVEYORS LAND PLANNERS CONSTRUCTION MANAGERS CONSULTANTS

REV

LYTTON HILLS SUBDIVISION AGREEMENT

This Phased Subdivision Development Subdivision Agreement for the Lytton Hills Subdivision (this "Agreement"), is made and entered into effective as of the 1st day of November 2018 (the "Effective Date") by and between Caldwell County, Texas (the "County") and Lytton Hills Owner, Beau King, (the "Subdivision Declarant" or "Declarant"). The County and Declarant are sometimes referred to herein as the "Parties". The Parties agree as follows:

Purposes, Term and Consideration

- 1.01. Declarant has acquired 579.256 acres located in the Jonathan Burleson Survey, Abstract No. 34, The Issac Allen Survey, Abstract No. 28 and the Pablo Martinez Survey, Abstract No. 181, Caldwell County, Texas, said 579.256 acres being all of that certain 327.923 acre tract of land recorded in document No. 2015-003871, official public record, Caldwell County, Texas and the remaining portion of a called 421.890 acre tract of land recorded in document No 2016-000677, official public records, Caldwell County, Texas, and more particularly described in Exhibit "A" attached hereto and incorporated herein by reference. The above-described property, whether one or more parcels, is hereinafter referred to as the "Property".
- 1.02. Declarant is authorized to enter into this Subdivision Agreement with County. The County is authorized to enter into this Subdivision Agreement with Declarant by authority of Chapter 232 of the Texas Local Government Code, Subchapter E, and Section 3.5 of the Caldwell County Development Ordinance.
- 1.03. Declarant desires to subdivide the Property as a single family residential subdivision in accordance with the Master Plan as more particularly described in the Map depicted in Exhibit "C" attached hereto and incorporated herein by reference.
- 1.04. The benefit to the Parties set forth in this Agreement which exceed the minimum requirements of State law and Caldwell County Development Ordinance are good and valuable consideration for this Agreement, the sufficiency of which is hereby acknowledged by both Parties.

The Project

- 2.01. The Project, as that term is described in Chapter 245, Texas Local Government Code, is the master planning and subdivision platting of the Property into 109 single family residential home sites; the laying out of streets, drainage facilities and other improvements; the installation of electric, telephone, and the construction of water lines. The project is subject to the Caldwell County Development Regulations as they existed in November 2018 except as modified by this Agreement.
- 2.02. Declarant and County agree that before Caldwell County will accept for recording any final subdivision plat of all or any portion of the Property:
 - A. Declarant shall construct all streets and drainage facilities dedicated by said final plat in

accordance with County street and drainage standards or provide fiscal surety for 100% of the estimated cost of street and drainage improvements.

- B. Declarant shall demonstrate to the County's reasonable satisfaction that it has developed or secured contract commitments from a State approved public water supply in sufficient capacity to serve the final plat portion of the Property.
 - C. Declarant shall demonstrate to the County's reasonable satisfaction that all lots are to be served by OSSF and to be constructed prior to occupying any structures.
 - D. Declarant shall construct all water, electric and communication facilities necessary to serve the platted portion of the Property in accordance with all applicable County and/or State standards and regulations.
- 2.03 Declarant agrees to file an overall Preliminary Plan for the entire tract. The Project will be designed, developed, installed and constructed in proposed multiple phases which may vary plus or minus ten percent (10%) from the proposed phasing plan, which is attached hereto as Exhibit B and incorporated herein for all purposes, as necessary to improve the overall design of the Project. The proposed number of home sites in each phase may vary from the proposed phasing and may differ from the Preliminary Plan, but the total number of home sites in the Project may not exceed 109 and 15% impervious cover of the total land area. Declarant agrees to submit review, platting, and inspection fees in accordance with the County's fee schedule effective at the date each application / plat is submitted.
- 2.04 The Parties agree that, if Declarant fails to submit a final plat application within two (2) years of the dates provided for any of the proposed phases described in Exhibit B, that the Project shall expire, that the submittal of a new preliminary plan for the Lytton Hills Subdivision shall be required, and that, for the purposes of Chapter 245 of the Texas Local Government Code, Declarant's new "project" shall run from the date a new preliminary plan is submitted to the County.

The County Street and Drainage Standards

- 3.01 Declarant and County agree that all internal streets and driveways within the Property shall be built in accordance with standards described in the Caldwell County Development Ordinance, as those Regulations existed in November 2018 except as modified by this Agreement.
- 3.02 All internal street improvements shall be initially built at Declarant's sole and exclusive costs and expense.
- 3.03 The County agrees to timely process one or more preliminary subdivision plans and final plats of the Property submitted by Declarant's licensed engineer in accordance with the Caldwell County Development Ordinance, as those standards existed in November 2018 except as modified by this Agreement, and in accordance with the Preliminary Master Plan attached hereto as Exhibit "C", which shall be approved on the Effective Date of this Agreement.
- 3.04 Declarant shall dedicate to the County with each final plat of a portion of the Property all ***rights of way containing roads and related drainage improvements*** within said final plat and dedicate to the appropriate utility service provider all electric, water, sewer and communication utility easements as necessary to serve the final plat.

- 3.05 Declarant agrees to dedicate *ownership and maintenance of all storm water treatment and detention ponds* within each final plat section of the Property to a statutory district or a homeowner association. The drainage and detention facilities shall be built in accordance with County standards, as those standards existed in November 2018 except as modified by this Agreement, and shall be designed to serve the Property assuming fully developed conditions. The Project shall adopt the FEMA approved 100-year, 24-hour storm model, assuming fully developed storm conditions. FEMA permitting, if required, will follow applicable NFIP regulations.

Assignment of Commitments and Obligations

- 4.01 Declarant's right and obligation under this Agreement may be assigned by Declarant to one or more purchasers of all or any portion of the Property.
- 4.02 Upon approval of the Preliminary Plan, this Agreement and the associated Preliminary Plan shall be binding upon the Parties, their successors and assigns and shall be effective for a term of ten (10) years from the date of this Agreement unless renewed and extended by mutual Agreement of the Parties.

Default

- 5.01 Notwithstanding anything herein to the contrary, no Party shall be deemed to be in default hereunder until the passage of thirty (30) business days after receipt by such party of notice of default from the other party. Upon the passage of thirty (30) business days without cure of the default, such party shall be deemed to have defaulted for purposes of this Agreement.

Notices

- 6.01 Any notice to be given hereunder by any party shall be in writing and may be effected by personal delivery or by sending said notice by registered or certified mail, return receipt requested, to the addresses set forth below. Notice shall be deemed given when deposited with the United States Postal Service with sufficient postage affixed.

Any notice mailed to Caldwell County shall be addressed to:

Ken Schawe
Caldwell County Judge
110 S. Main Street, Suite 201
Lockhart, Texas 78644

An additional copy shall be send to:
Kasi Miles
Director of Sanitation
Caldwell County
1700 FM 2720 Lockhart, Texas 78644 (512) 398-1803

Any notice mailed to Declarant shall be addressed to:

Mr. Beau King

Millennium Interests, Ltd.

1718 State Street

Houston, Texas 77077

(888) 774-5720 office

Any Party may change the address for notice to it by giving notice of such change in accordance with the provisions of this section.

Entire Agreement

- 7.01 This Agreement, together with any exhibits attached hereto, constitutes the entire Agreement between Parties hereto, and may not be amended except in writing signed by all Parties and dated subsequent to the date hereof.

(SIGNATURES FOLLOW ON THE NEXT PAGE)

The above-stated Subdivision Agreement for the Lytton Hills Subdivision is hereby EXECUTED in multiple originals to be effective as of the ____ day of _____, 2017.

CALDWELL COUNTY TEXAS

By: _____
Name: _____
Title: _____

Date: _____

Attest: _____
Carol Holcomb
Caldwell County Clerk

Beau King
Millennium Interests, LTD

By: _____
Name: _____
Title: _____

Date: _____

THE STATE OF TEXAS §
 §
COUNTY OF CALDWELL §

This instrument was acknowledged before me on the _____ day of _____, 20__, by _____, _____ of _____ Millennium Interests, LTD.

NOTARY PUBLIC, State of Texas

EXHIBIT A

Metes and Bounds Description of the Property

MATKIN HOOVER

ENGINEERING & SURVEYING

8 SPENCER ROAD, SUITE 100, BOERNE, TEXAS 78006
PHONE: 830-249-0600 FAX: 830-249-0099
TEXAS REGISTERED SURVEYING FIRM F-10024000

FIELD NOTES FOR A 579.259 ACRE TRACT OF LAND

BEING A 579.259 ACRE TRACT OF LAND LOCATED IN THE JONATHAN BURLESON SURVEY, ABSTRACT NO. 34, THE ISAAC ALLEN SURVEY, ABSTRACT NO. 28, AND THE PABLO MARTINEZ SURVEY, ABSTRACT NO. 181, CALDWELL COUNTY, TEXAS, BEING THE REMAINING PORTION OF A CALLED 421.890 ACRE TRACT RECORDED IN DOCUMENT NO. 2016-000677, OFFICIAL PUBLIC RECORDS OF CALDWELL COUNTY, TEXAS, AND ALL OF THAT CERTAIN CALLED 327.923 ACRE TRACT RECORDED IN DOCUMENT NO. 2015-003871, OFFICIAL PUBLIC RECORDS OF CALDWELL COUNTY, TEXAS. SAID 579.259 ACRE TRACT BEING MORE PARTICULARLY DESCRIBED BY METES AND BOUNDS AS FOLLOWS:

Beginning at a 5/8" iron rod with a yellow plastic cap found in the southwest right-of-way line of F.M. 1854 (80' right-of-way) at a north corner of the called 327.923 acre tract, an angle point in the southeast boundary line of a the remaining portion of a called 50 acre tract designated as "Tract 2" recorded in Volume 99, Page 137, Official Public Records of Caldwell County, Texas;

- (1) Thence, with the southwest right-of-way line of F.M. 1854, the northeast boundary line of the called 327.923 acre tract, a northeast boundary line of the herein described tract, with the arc of a curve to the left, with a radius of 858.51', a central angle of 44° 32' 45", an arc length of 667.47', and a chord which bears S 02° 43' 18" E, a distance of 650.78' to a ½" iron rod found for corner at an east corner of the called 327.923 acre tract, said point being the north corner of a called 12.000 acre tract recorded in Document No. 2016-001642, Official Public Records of Caldwell County, Texas;**
- (2) Thence, S 51° 59' 10" W, departing the southwest right-of-way line of F.M. 1854, with the southeast boundary line of the called 327.823 acre tract, the northwest boundary line of the called 12.000 acre tract, a southeast boundary line of the herein described tract, a distance of 1665.12' to a ½" iron rod with a "Matkin Hoover Eng. & Survey" plastic cap found for interior corner at the west corner of the called 12.00 acre tract;**
- (3) Thence, S 25° 26' 28" E, departing the southeast boundary line of the called 327.923 acre tract, with the southwest boundary line of the called 12.000 acre tract, and the southwest boundary line of a called 10.05 acre tract, recorded in Document No. 2016-002693, Official Public Records of Caldwell County, Texas, a northeast boundary line of the herein described tract, a distance of 982.93' to a ½" iron rod with a "Matkin Hoover Eng. & Survey" plastic cap found for corner at the south corner of the called 10.05 acre tract, in the northwest boundary line of a called 10.33 acre tract, recorded in Document No. 2016-003872, Official Public Records of Caldwell County, Texas;**
- (4) Thence, with the northwest and west boundary line of the called 10.33 acre tract, the southeast and east boundary line of the herein described tract, the following courses and distances:**

- a. **S 52° 06' 04" W, 181.59'** to a ½" iron rod with a "Matkin Hoover Eng. & Survey" plastic cap found for angle;
 - b. **S 43° 46' 48" W, 492.39'** to a ½" iron rod with a "Matkin Hoover Eng. & Survey" plastic cap found for angle;
 - c. **S 01° 30' 22" W, 148.66'** to a ½" iron rod with a "Matkin Hoover Eng. & Survey" plastic cap found for angle;
 - d. **S 46° 13' 12" E, 60.00'** to a ½" iron rod with a "Matkin Hoover Eng. & Survey" plastic cap found for corner at a north corner of a called 11.99 acre tract, recorded in Document No. 2016-003868, Official Public Records of Caldwell County, Texas;
- (5) **Thence, S 43° 42' 16" W**, with the northwest boundary line of the called 11.99 acre tract, a southeast boundary line of the herein described tract, a **distance of 872.55'** to a ½" iron rod with a "Matkin Hoover Eng. & Survey" plastic cap found for interior corner at the west corner of the called 11.99 acre tract;
- (6) **Thence, S 33° 21' 45" E**, with the southwest boundary line of the called 11.99 acre tract, a northeast boundary line of the herein described tract, a **distance of 96.94'**, to a ½" iron rod with a "Matkin Hoover Eng. & Survey" plastic cap found for an angle at an angle point of the called 11.99 acre tract;
- a. **Thence, S 46° 17' 44" E**, with the southwest boundary line of the called 11.99 acre tract, the southwest boundary line of a called 10.74 acre tract, recorded in Document No. 2016-006231, Official Public Records of Caldwell County, Texas, the southwest boundary line of a called 13.75 acre tract, recorded in Document No. 2017-002027, Official Public Records of Caldwell County, Texas, and the southwest boundary line of a called 12.17 acre tract, recorded in Document No. 2017-000716, Official Public Records of Caldwell County, Texas, a northeast boundary line of the herein described tract, a **distance of 1372.98'** to a ½" iron rod with a "Matkin Hoover Eng. & Survey" plastic cap found for corner at the south corner of the called 12.17 acre tract, in the southeast boundary line of the called 421.890 acre tract, said point being in the northwest boundary line of a called 107.11 acre tract, recorded in Volume 240, Page 257, Official Public Records of Caldwell County, Texas;
- (7) **Thence, S 43° 42' 16" W**, with the northwest boundary line of the called 107.11 acre tract, the northwest lines of Lots 3 and 4, Reata Ranch, Section 2, recorded in Cabinet A, Slide 198, Plat Records of Caldwell County, Texas, the southeast boundary line of the called 421.890 acre tract, the southeast boundary line of the herein described tract, a **distance of 3545.50'** (S 45° 25' 07" W, record) to a ½" iron rod found for south corner at the northwest corner of Lot 4, Reata Ranch, Section 2, in the northeast boundary line of the called 329.490 acre tract recorded in Volume 249, Page 645, Official Public Records of Caldwell County, Texas;
- (8) **Thence, N 46° 28' 37" W**, with the northeast boundary line of the called 329.490 acre tract, the northeast boundary line of a called 10.001 acre tract recorded in Document No. 2013-001005, Official Public Records of Caldwell County, Texas, the northeast boundary line of a called 11.997

acre tract recorded in Volume 304, Page 493, Official Public Records of Caldwell County, Texas, and the northeast boundary line of a called 13.000 acre tract recorded in Volume 621, Page 825, Official Public Records of Caldwell County, Texas, the southwest boundary line of the remaining portion of the called 421.890 acre tract, a southwest boundary line of the herein described tract, a **distance of 2543.88'** to a ½" iron rod found for angle at the north corner of the called 13.000 acre tract, the west corner of the called 421.890 acre tract, the east corner of a called 11.457 acre tract recorded in Document No. 2013-001009, Official Public Records of Caldwell County, Texas, and the south corner of the called 327.923 acre tract;

- (9) **Thence, N 46° 28' 18" W**, with the northeast boundary line of the called 11.457 acre tract, the northeast boundary line of a called 12.432 acre tract recorded in Volume 436, Page 843, Official Public Records of Caldwell County, Texas, the northeast boundary line of a called 12.442 acre tract recorded in Volume 358, Page 839, Official Public Records of Caldwell County, Texas, and a portion of the northeast boundary line of a called 12.231 acre tract recorded in Volume 412, Page 870, Official Public Records of Caldwell County, Texas, a southwest boundary line of the called 327.923 acre tract, a southwest boundary line of the herein described tract, a **distance of 1644.10'** to a ½" iron rod found for west corner at the west corner of the called 327.923 acre tract, the south corner of a called 87.717 acre tract recorded in Volume 360, Page 214, Deed Records of Caldwell County, Texas;
- (10) **Thence, N 43° 18' 23" E**, departing the northeast boundary line of the called 12.231 acre tract, with the southeast boundary line of the called 87.717 acre tract, and the southeast boundary line of the King Family Trust tracts recorded in Volume 378, Page 624, Official Public Records of Caldwell County, Texas, a northwest boundary line of the called 327.923 acre tract, a northwest boundary line of the herein described tract, a **distance of 5187.45'** to a ½" iron rod found for interior corner, at an interior corner of the called 327.923 acre tract, an east corner of the King Family Trust Tracts;
- (11) **Thence, N 46° 25' 27" W**, with a northeast boundary line of the King Family Trust tracts, a southwest boundary line of the called 327.923 acre tract, a southwest boundary line of the herein described tract, a **distance of 1396.08'** to a ½" iron rod found for corner at a west corner of the called 327.923 acre tract, the south corner of a called 26.68 acre tract recorded in Document No. 2012-006724, Official Public Records of Caldwell County, Texas;
- (12) **Thence, N 44° 02' 39" E**, departing the southeast boundary line of the King Family Trust tracts, with the southeast boundary line of the called 26.68 acre tract, and the southeast boundary line of a called 26.85 acre tract recorded in Volume 174, Page 748, Official Public Records of Caldwell County, Texas, a northwest boundary line of the called 327.923 acre tract, a northwest boundary line of the herein described tract, a **distance of 1736.19'** to a 5/8" iron rod with a yellow "RPLS 1573" plastic cap found for north corner at the north corner of the called 327.923 acre tract, in the southwest boundary line of a called 32.583 acre tract, recorded in Volume 239, Page 857, Official Public Records of Caldwell County, Texas;
- (13) **Thence, S 46° 37' 43" E**, departing the southeast boundary line of the called 26.85 acre tract, with the southwest boundary line of the called 32.583 acre tract, the southwest boundary line of the remaining portion of a called 100 acre tract, designated as "Tract 1" recorded in Volume 99, Page 137, Official Public Records of Caldwell County, Texas, and the southwest boundary line of the

remaining portion of the called 50 acre tract, the northeast boundary line of the called 327.923 acre tract, the northeast boundary line of the herein described tract, a distance of 2866.31' to a 10" wood fence post found for interior corner at an interior corner of the called 327.923 acre tract, the south corner of the remaining portion of the called 50 acre tract;

- (14) Thence, N 43° 10' 52" E, with the southeast boundary line of the remaining portion of the called 50 acre tract, a northwest boundary line of the called 327.923 acre tract, a northwest boundary line of the herein described tract, a distance of 744.38' to the POINT OF BEGINNING and containing 579.259 acres of land, more or less.

Note: The basis of bearing was established using the Trimble VRS Network, NAD (83), Texas State Plane Coordinate System, Central Zone, US Survey Foot, Grid. A survey plat was prepared by a separate document.



A handwritten signature in blue ink, appearing to read "Jeff Boerner", is written over a horizontal line.

Jeff Boerner Date: 08-25-2017
RPLS #4939
Job #16-4009 579.259 ACRES

EXHIBIT B

LYTTON HILLS PROJECT BY PROJECT PHASE

Phase*	1	2	3	4	5
Max. No. of Lots**	75	34			
Est. Date of Final Plat Submittal	May 2019	June 2019			

***Phase location can be found in Exhibit C.**

****Lot counts shown in Exhibit B supersede those shown in Exhibit C.**

EXHIBIT C

OVERALL MASTER DEVELOPMENT PLAN
FOR
LYTTON HILLS, PHASE ONE
CALDWELL COUNTY, TEXAS

CS100
DATE: 07/11/11
DRAWN BY: JY
CHECKED BY: JY
SCALE: AS SHOWN

MATKINHOVER
ENGINEERING & SURVEYING
11111 N. LOOP WEST, SUITE 100
DALLAS, TEXAS 75243
PHONE: (214) 343-1111
FAX: (214) 343-1112
WWW.MATKINHOVER.COM

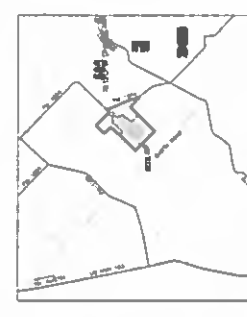

LEGEND

PHASE 1 BOUNDARY
PHASE 2 BOUNDARY
PHASE 1 LOT LINES
PHASE 2 LOT LINES
PHASE 1 DRIVEWAYS
PHASE 2 DRIVEWAYS
PHASE 1 UTILITY LINES
PHASE 2 UTILITY LINES
PHASE 1 EASEMENTS
PHASE 2 EASEMENTS
PHASE 1 EXISTING IMPROVEMENTS
PHASE 2 EXISTING IMPROVEMENTS

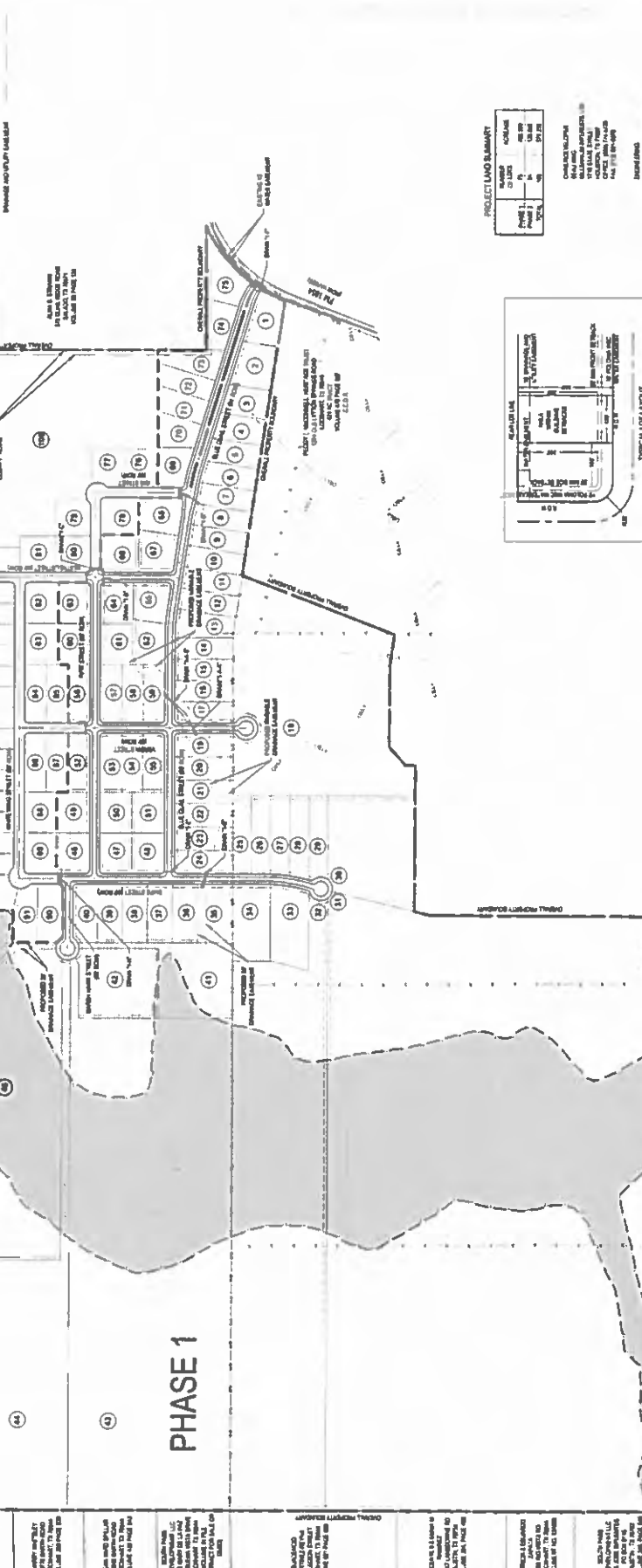

PROJECT LAND SUMMARY

TYPE	ACRES	PERCENT
TOTAL	100.00	100.00%
PHASE 1	44.00	44.00%
PHASE 2	56.00	56.00%

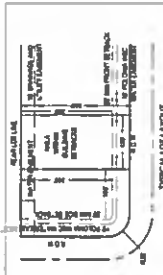

PHASE 2

PHASE 2 BOUNDARY

PHASE 2 LOT LINES

PHASE 2 DRIVEWAYS

PHASE 2 UTILITY LINES

PHASE 2 EASEMENTS

PHASE 2 EXISTING IMPROVEMENTS

PHASE 1

PHASE 1 BOUNDARY

PHASE 1 LOT LINES

PHASE 1 DRIVEWAYS

PHASE 1 UTILITY LINES

PHASE 1 EASEMENTS

PHASE 1 EXISTING IMPROVEMENTS

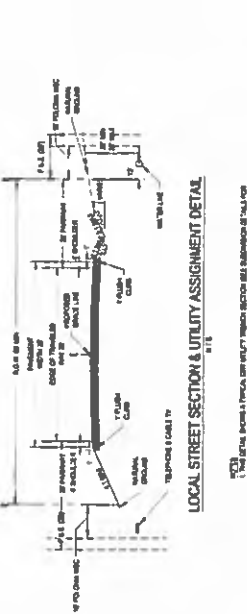

NOTES:

1. THIS PLAN IS A PRELIMINARY PLAN AND IS SUBJECT TO THE APPROVAL OF THE CALDWELL COUNTY COMMISSIONERS COURT AND THE CALDWELL COUNTY ENGINEER.
2. THE PROPERTY IS SUBJECT TO THE CALDWELL COUNTY SUBDIVISION ACT AND THE CALDWELL COUNTY SUBDIVISION RULES AND REGULATIONS.
3. THE PROPERTY IS SUBJECT TO THE CALDWELL COUNTY ZONING ORDINANCES AND THE CALDWELL COUNTY ZONING COMMISSION.
4. THE PROPERTY IS SUBJECT TO THE CALDWELL COUNTY UTILITY ORDINANCES AND THE CALDWELL COUNTY UTILITY COMMISSION.
5. THE PROPERTY IS SUBJECT TO THE CALDWELL COUNTY EASEMENT ORDINANCES AND THE CALDWELL COUNTY EASEMENT COMMISSION.
6. THE PROPERTY IS SUBJECT TO THE CALDWELL COUNTY EXISTING IMPROVEMENTS ORDINANCES AND THE CALDWELL COUNTY EXISTING IMPROVEMENTS COMMISSION.

31. Discussion/Action to discuss Employee Compensation for FY 2020 budget cycle.
Cost: TBD; Speaker: Judge Haden;
Backup: 1

Caldwell County Agenda Item Request Form

To: All Elected Officials and Department Heads – Hand deliver or scan & email to hoppy.haden@co.caldwell.tx.us and ezzy.chan@co.caldwell.tx.us . Deadline is 5:00 pm Tuesday before the Regular meetings, however, please submit this completed form ASAP. "Anything missing will cause the Agenda Item to be held over to the next Regular meeting," according to our Rules & Procedures.

AGENDA DATE: 5/13/2019

Type of Agenda Item

- Consent Discussion/Action Executive Session Workshop
 Public Hearing

What will be discussed? What is the proposed motion?

To discuss Employee compensation for FY 2020 budget cycle.

1. **Costs:**

Actual Cost or Estimated Cost \$ TBD

Is this cost included in the County Budget? _____

Is a Budget Amendment being proposed? _____

2. **Agenda Speakers:**

	Name	Representing	Title
--	------	--------------	-------

(1) Judge Haden

(2) _____

(3) _____

3. **Backup Materials:** None To Be Distributed _____ total # of backup pages
(including this page)

4. 
Signature of Court Member

5/7/2019
Date

32. EXECUTIVE SESSION pursuant to Sections 551.071 and 551.087 of the Texas Government Code: consultation with counsel and deliberation regarding economic development negotiations associated with Fashion Glass and Mirror, L.L.C. Possible action may follow in open court. **Cost: TBD; Speaker: Judge Haden; Backup: None.**

33. Adjournment.

As authorized by Chapter 551 of the Texas Government Code, the Commissioners Court of Caldwell County, Texas reserves the right to adjourn into Executive Session at any time during the course of this meeting to discuss any of the matters listed above. The Court may adjourn for matters that may relate to Texas Government Code Section 551.071(1) (Consultation with Attorney about pending or contemplated litigation or settlement offers); Texas Government Code Section 551.071(2) (Consultation with Attorney when the attorney's obligation under the Texas Disciplinary Rules of Professional Conduct of the State Bar of Texas conflicts with Chapter 551 of the Texas Government Code); Texas Government Code Section 551.072 (Deliberations about Real Property); Texas Government Code Section 551.073 (Deliberations about Gifts and Donations); Texas Government Code Section 551.074 (Personnel Matters); Texas Government Code Section 551.0745 (Deliberations about a County Advisory Body); Texas Government Code Section 551.076 (Deliberations about Security Devices); and Texas Government Code Section 551.087 (Economic Development Negotiations). In the event that the Court adjourns into Executive Session, the Court will announce under what section of the Texas Government Code the Commissioners Court is using as its authority to enter into an Executive Session. The meeting facility is wheelchair accessible and accessible parking spaces are available. Request for accommodations or interpretive services must be made 48 hours prior to this meeting. Please contact the County Judge's office at 512-398-1808 for further information. www.co.caldwell.tx.us